

# TECHNICAL NOTE

## MS8000 Evaluation board - EVBA

30TN.EVB-MS8X.K.05.11

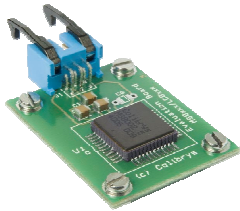

MS8000 evaluation board

### Features

- MS8000 accelerometer on board
- Fully assembled
- All ranges available
- Analog voltage output (0.5V to 4.5V)
- RoHS compliant suitable for lead free soldering process and SMD mounting

### Introduction

The Evaluation Board EVBA version offers to the user a simple and quick means to evaluate the main functionality and a full performance of the Colibrys MS8000 and HS8000 accelerometer series.

The MS8000 products are MEMS capacitive accelerometer based on a bulk micro-machined silicon element, a low power ASIC for signal conditioning, a micro-controller for storage of compensation values and a temperature sensor. The MS8000 are operating from a single power supply voltage (between 2.5V and 5.5V) with a low current consumption (< 0.5mA at 5V). The output is a ratiometric analog voltage that varies between 0.5V and 4.5V for the full-scale acceleration range at a voltage supply of 5V.

The sensor is fully self-contained and packaged in a 20-pin LCC ceramic housing, thus insuring full hermeticity. It operates over a temperature range of -55°C to 125°C and can withstand shocks up to 1000g without performance degradation. For further technical information please refer to the related specification and product description.

### EVBA general description

This small Evaluation Board circuit is intended to help the system designer or qualification engineer to speed-up the evaluation and integration of the MS/HS8000 accelerometer series to any new or upgraded systems. It is simple to use and as no additional components are required, it can easily be connected to a power supply and a voltmeter to read the accelerometer output and temperature signal through the 6-pin connector.

### Board layout and components

The EVBA is very simple and mainly comprises the MEMS accelerometer and three decoupling capacitors. The precise evaluation board components and related functionality are summarized in the following table.

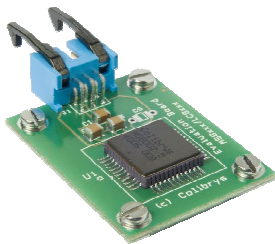

Component	Value	Function
C1	1 $\mu$ F	Decoupling capacitor VDD – VSS
C2	1 $\mu$ F	Decoupling capacitor VAGND - VDD
C3	1 $\mu$ F	Decoupling capacitor VAGND – VSS
J1	Connector	See following figure for details
J2	End connector	See following figure for details
U1	Accelerometer	1 axis accelerometer
Screw	Diam 2.5 mm	To fix the evaluation board
Spacer	Diam 6 mm	To isolate the back side of the board

A schematic of the EVBA and the layout and the outline dimensions are presented in the following figures.

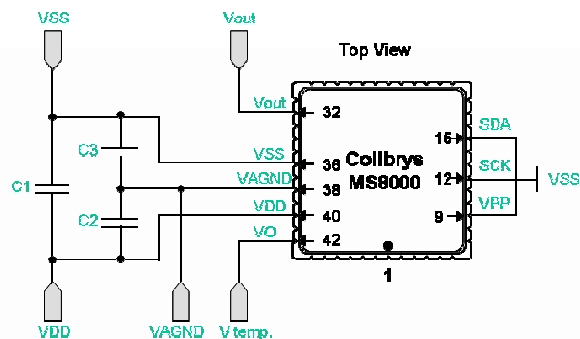

# TECHNICAL NOTE

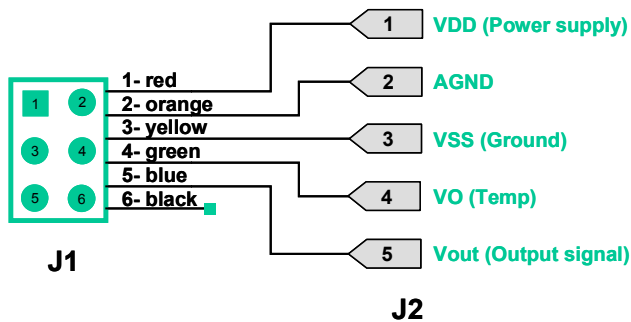
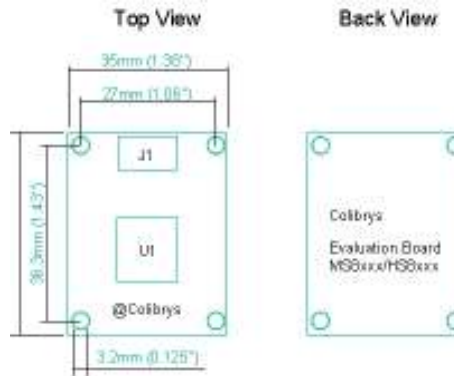
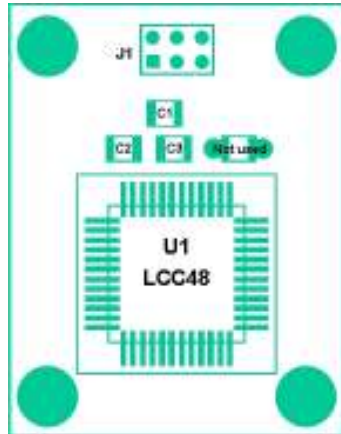

J1 and J2 connectors must not be used for frequency vibration measurements.

The connection cable must be fixed directly on the EVBA.

Vout: from 0.5 to 4.5 VDC @ 5 VDC input voltage. (2.5 V ± 10 mv at 0g)

### Mounting recommendations

The EVBA is designed to be mounted easily in various evaluation environments; the shaker (for dynamic measurements), the tumble table (for static and dynamic measurement) and the oven (for temperature measurement).

The sensitive axis (Z-axis) is perpendicular to the plan of EVBA. The mounting of the EVBA is critical to insure the best measurements. Therefore it is important to mount the EVBA as tightly as possible to obtain accurate performance.

The connection cable, screw and spacer are also provided to guarantee a correct connection, fixation and isolation in different evaluation environments.