

INTERNATIONAL STANDARD

ISO 10135

Second edition
2007-11-15

Geometrical product specifications (GPS) — Drawing indications for moulded parts in technical product documentation (TPD)

*Spécification géométrique des produits (GPS) — Indications sur les
dessins pour pièces moulées dans la documentation technique de
produits (TPD)*



Provided by IHS under license with ISO

Reference number
ISO 10135:2007(E)

© ISO 2007

PDF disclaimer

This PDF file may contain embedded typefaces. In accordance with Adobe's licensing policy, this file may be printed or viewed but shall not be edited unless the typefaces which are embedded are licensed to and installed on the computer performing the editing. In downloading this file, parties accept therein the responsibility of not infringing Adobe's licensing policy. The ISO Central Secretariat accepts no liability in this area.

Adobe is a trademark of Adobe Systems Incorporated.

Details of the software products used to create this PDF file can be found in the General Info relative to the file; the PDF-creation parameters were optimized for printing. Every care has been taken to ensure that the file is suitable for use by ISO member bodies. In the unlikely event that a problem relating to it is found, please inform the Central Secretariat at the address given below.



COPYRIGHT PROTECTED DOCUMENT

© ISO 2007

All rights reserved. Unless otherwise specified, no part of this publication may be reproduced or utilized in any form or by any means, electronic or mechanical, including photocopying and microfilm, without permission in writing from either ISO at the address below or ISO's member body in the country of the requester.

ISO copyright office
Case postale 56 • CH-1211 Geneva 20
Tel. + 41 22 749 01 11
Fax + 41 22 749 09 47
E-mail copyright@iso.org
Web www.iso.org

Published in Switzerland

Contents

Page

Foreword.....	iv
Introduction	v
1 Scope	1
2 Normative references	1
3 Terms and definitions	2
4 Letter Symbols	2
5 Line conventions	3
6 Drawing indications for moulded parts	3
6.1 Parting surface.....	3
6.2 Tool markings	5
6.3 Special ejector markings identifier	6
6.4 Mismatch	7
6.5 Flash.....	11
6.6 Extent of specification	13
6.7 Draft angles	20
6.8 Tool motion direction	32
6.9 Part removal direction	34
6.10 Surface enlargement	35
6.11 Sinks	36
6.12 Porosity.....	37
6.13 Identification and marking	37
6.14 Other necessary information.....	38
6.15 Special indication for undisturbed surfaces.....	39
7 Rules for linear and geometrical dimensioning and tolerancing	39
7.1 Linear dimensioning and tolerancing.....	39
7.2 Geometrical tolerancing.....	43
7.3 Datums.....	43
7.4 Surface texture.....	43
7.5 Edges	43
Annex A (normative) Proportions and dimensions of graphical symbols.....	44
Annex B (informative) Former practice (tapered features)	48
Annex C (informative) Relation to the GPS matrix model	50
Bibliography	51

Foreword

ISO (the International Organization for Standardization) is a worldwide federation of national standards bodies (ISO member bodies). The work of preparing International Standards is normally carried out through ISO technical committees. Each member body interested in a subject for which a technical committee has been established has the right to be represented on that committee. International organizations, governmental and non-governmental, in liaison with ISO, also take part in the work. ISO collaborates closely with the International Electrotechnical Commission (IEC) on all matters of electrotechnical standardization.

International Standards are drafted in accordance with the rules given in the ISO/IEC Directives, Part 2.

The main task of technical committees is to prepare International Standards. Draft International Standards adopted by the technical committees are circulated to the member bodies for voting. Publication as an International Standard requires approval by at least 75 % of the member bodies casting a vote.

Attention is drawn to the possibility that some of the elements of this document may be the subject of patent rights. ISO shall not be held responsible for identifying any or all such patent rights.

ISO 10135 was prepared by Technical Committee ISO/TC 213, *Dimensional and geometrical product specifications and verification*.

This second edition cancels and replaces the first edition (ISO 10135:1994), which has been technically revised.

Introduction

This International Standard is a technical product documentation (TPD) standard (as prepared by ISO/TC 10), but also serves as a geometrical product specification (GPS) standard (as prepared by ISO/TC 213) and is to be regarded as a complementary process specific tolerance GPS standard (see ISO/TR 14638). It influences links 1 and 2 of the chain of standards on mouldings.

For more detailed information of the relation of this International Standard to other standards and the GPS matrix model, see Annex B.

Materials that are moulded to produce parts may exist in a solid, doughy or liquid form.

In order to produce parts by moulding, it is recognized that special consideration has to be made concerning the moulding process and the designs of the mould, which influence the design of the part.

It is often necessary to slightly change the intended geometry of a part in order to avoid surface imperfections (e.g. caused by sinks due to thermal contraction of material) and in order to enable the removal of the part from the mould. Different necessary mould components such as parting surfaces, gates, risers, vents, ejectors etc. can also produce undesired, but inevitable surface imperfections. Therefore, the resulting moulded part will exhibit deviations from the ideal geometric form. To control these deviations in order to achieve the intended function and to ensure that the moulded part can be reproduced when a mould shall be replaced (e.g. due to breakdown), it is necessary that such permissible deviations be able to be indicated and specified on technical drawings.

Moulded parts, cast parts and forged parts are parts produced by the use of a mould, e.g. by blowing, injection, casting or forging. For convenience, the use of the term "moulded part" in the text of this International Standard covers moulded or cast or forged parts.

The tolerance specified for a casting may determine the casting method. It is therefore recommended, before the design or the order is finalized, that the customer liaise with the foundry to discuss:

- a) the proposed casting design and accuracy required;
- b) machining requirements;
- c) method of casting;
- d) the number of castings to be manufactured;
- e) the casting equipment involved;
- f) datum target system according to ISO 5459;
- g) casting alloy;
- h) any special requirements, for instance, individual dimensional and geometrical tolerances, fillet radii tolerances and individual machining allowances.

Although the figures in this International Standard are presented in first angle projection, they could equally well have been presented using third angle projection.

Geometrical product specifications (GPS) — Drawing indications for moulded parts in technical product documentation (TPD)

1 Scope

This International Standard specifies rules and conventions for the indications of requirements for moulded parts on technical product documentation. It also specifies the proportions and dimensions of the graphical symbols used for this representation.

NOTE The figures in this International Standard merely illustrate the text and are not intended to reflect actual application. Consequently, the figures are simplified and are not fully dimensioned and toleranced, showing only the relevant general principles applicable in any technical area.

2 Normative references

The following referenced documents are indispensable for the application of this document. For dated references, only the edition cited applies. For undated references, the latest edition of the referenced document (including any amendments) applies.

ISO 128-22:1999, *Technical drawings — General principles of presentation — Part 22: Basic conventions and applications for leader lines and reference lines*

ISO 128-24:1999, *Technical drawings — General principles of presentation — Part 24: Lines on mechanical engineering drawings*

ISO 129-1:2004, *Technical drawings — Indication of dimensions and tolerances — Part 1: General principles*

ISO 406:1987, *Technical drawings — Tolerancing of linear and angular dimensions*

ISO 1101:2004, *Geometrical Product Specifications (GPS) — Geometrical tolerancing — Tolerancing of form, orientation, location and run-out*

ISO 1302:2002, *Geometrical Product Specifications (GPS) — Indication of surface texture in technical product documentation*

ISO 2692:2006, *Geometrical product specifications (GPS) — Geometrical tolerancing — Maximum material requirement (MMR), least material requirement (LMR) and reciprocity requirement (RPR)*

ISO 5459:—¹⁾, *Geometrical product specifications (GPS) — Geometrical tolerancing — Datums and datum-systems*

ISO 7083:1983, *Technical drawings — Symbols for geometrical tolerancing — Proportions and dimensions*

ISO 8062-1:2007, *Geometrical product specifications (GPS) — Dimensional and geometrical tolerances for moulded parts — Part 1: Vocabulary*

1) To be published. (Revision of ISO 5459:1981)

ISO 8785:1998, *Geometrical product specifications (GPS) — Surface imperfections — Terms, definitions and parameters*

ISO 13715:2000, *Technical drawings — Edges of undefined shape — Vocabulary and indications*

ISO/TR 14638:1995, *Geometrical Product Specifications (GPS) — Masterplan*

ISO 14660-1:1999, *Geometrical Product Specifications (GPS) — Geometrical features — Part 1: General terms and definitions*

ISO 14660-2:1999, *Geometrical Product Specifications (GPS) — Geometrical features — Part 2: Extracted median line of a cylinder and a cone, extracted median surface, local size of an extracted feature*

ISO 81714-1:1999, *Design of graphical symbols for use in the technical documentation of products — Part 1: Basic rules*

3 Terms and definitions

For the purposes of this document, the terms and definitions given in ISO 8062-1, ISO 14660-1 and ISO 14660-2 and the following apply.

3.1

global specification

specification that applies to all features concerned

3.2

partial specification

specification which applies to a limited group of features concerned

4 Letter Symbols

For the purposes of this International Standard, the letter symbols given in Table 1 apply.




Table 1 — Letter Symbols

Letter symbol	Interpretation	Reference
C	Core	6.1
E	Ejector	6.2
FL	Flash	6.5
FLF	Flash free	6.5.3
G	Gate	6.2
H	Heat dissipation (chill markings)	6.2
M	Main	6.1
PRD	Part removal direction	6.9
R	Riser	6.2
S	Slider (side core)	6.1
SMI	Surface mismatch	6.4
TF	Taper (draft) to fit	6.7.5
TM	Taper –	6.7.3
TMD	Tool motion direction	6.8
TP	Taper +	6.7.3
V	Vent	6.2

5 Line conventions

Line types and line widths shall be in accordance with ISO 128-24:1999 (see also Table 2). Rules for the presentation of graphical symbols are given in Annex A.

Table 2 — Lines

Line type representation	Line type No. according to ISO 128-24	Application
	01.2	Parting line of moulds in views
	04.2	Parting lines of moulds in sections Indication of restricted area
	05.1	Initial outlines prior to forming Outlines of the finished part within blanks Framing of particular fields/areas

6 Drawing indications for moulded parts

6.1 Parting surface

The parting surface between two shaping mould components is represented by the graphical symbol shown in Figure 1 a). Identification of fixed as well as movable mould parts is performed by filling in the particular half of the parting surface symbol as shown in Figure 1 b). The filled half represents the fixed mould part and the other half represents the movable part. For details of the symbol, see Figure A.1.



Figure 1 — Graphical symbol for parting surface

Outside to the left of the upper half of the graphical symbol representing the parting surface a letter symbol may be added to indicate the type of parting surface as shown in Table 3, Figure 2 and Figure 3. For details of the symbol, see Figures A.1 and A.2.

Table 3 — Letter symbol for types of parting surface

Letter symbol	Application
C	Parting surface for cores
M	Main parting surface of moulds
S	Parting surface for sliders



Key

- a Position of the letter symbol for types of parting surface.

Figure 2 — Position of the letter symbol on the graphical symbol for parting surface

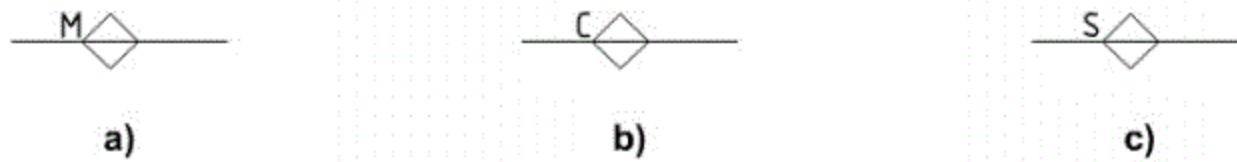


Figure 3 — Indication of specific types of parting surfaces

The parting surface shall be indicated in views by a line in accordance with Table 2. The graphical symbol representing the parting surface shall be positioned preferably outside the outlines of the moulded part, on the parting line representing the parting surface (see Figure 4).

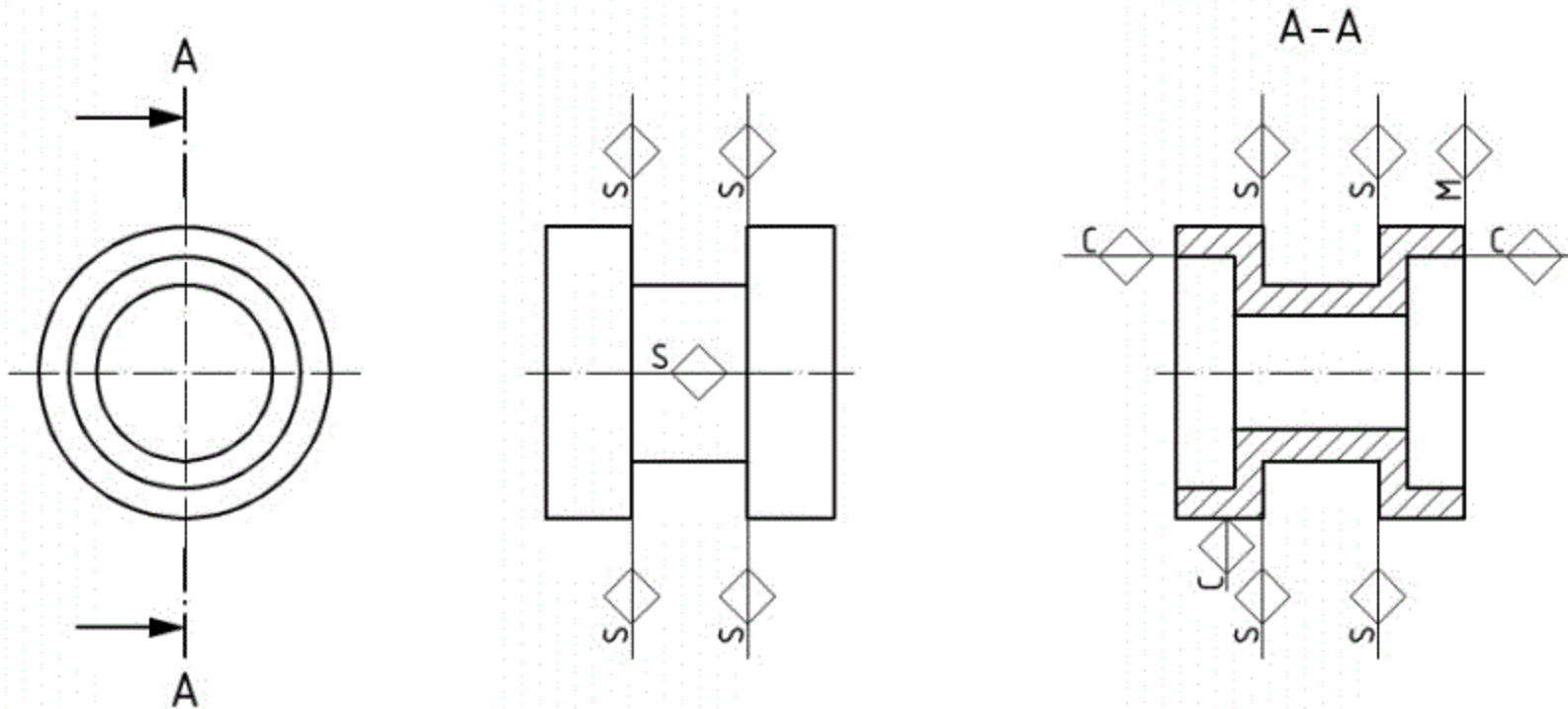
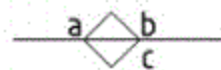


Figure 4 — Examples of the indication of parting surfaces

More than one graphical symbol may be used on a drawing to illustrate a single parting surface on a part.

If necessary, global specifications for maximum permissible mismatch and/or flash for all features intersected by a parting surface shall be indicated on the right hand side of only one of the graphical symbols used for illustrating the actual parting surface, see Figures 5 and 6. For more detailed information, see 6.4 and 6.5.



Key

- a Position of the letter symbol for types of parting surface.
- b Position of mismatch requirement.
- c Position of flash requirement.

Figure 5 — Position of the possible indications on the graphical symbol for parting surface

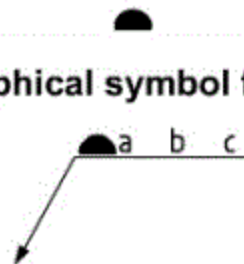


Figure 6 — Example of an indication of parting surface with specific type of parting surface, permissible mismatch and flash

6.2 Tool markings

When it is necessary to specify the size of the maximum permissible deflection caused by auxiliary mould components i.e. gates, risers, vents, ejectors and other types of tool markings, they shall be indicated by the graphical symbol shown in Figure 7. This shall be placed above a reference line (see ISO 128-22) connected to the feature by a leader line and an arrowhead, which is pointing to the surface as shown in Figure 8. The type of marking is indicated with a letter symbol according to Table 4 after the graphical symbol. If the type of marking is another than any of those listed in Table 4 the type shall be stated in full text/writing instead of a letter symbol. For details of the symbol, see Figure A.3.

Figure 7 — Graphical symbol for tool markings



Key

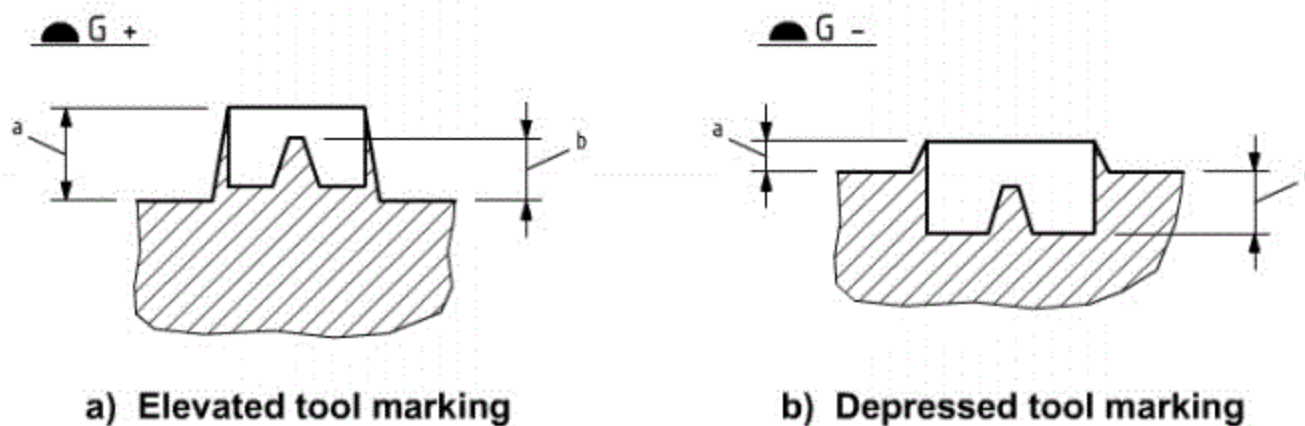
- a Position of indication of type of marking.
- b Position of indication of direction (elevated and/or depressed) using plus and minus signs.
- c Position of indication of dimension.

Figure 8 — Indication of tool marking symbol used with leader and reference lines

Table 4 — Letter symbol for types of tool marking

Letter symbol	Type of marking
E	Ejector markings
G	Gate markings
H	Heat dissipation (chill markings)
R	Riser markings
V	Vent markings

A plus and/or minus sign shall be indicated after the letter symbol or the text indicating the type of tool marking, see Figure 9. A plus sign is used if the tool marking shall be elevated above the adjacent surface of the moulded part as shown in Figure 9 a). A minus sign is used if the tool marking shall be depressed below the adjacent surface of the moulded part as shown in Figure 9 b). The plus and minus sign is used when elevation or depression is permitted.



- a Flash height.
- b Elevation.
- c Depression.

Figure 9 — Example of the interpretation of the combined flash and gate requirement

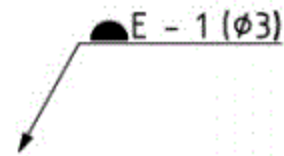
The maximum permissible local deviation of the tool mark from the surface may be indicated by adding values after the plus and/or minus sign, see Figure 10. The value representing the maximum permissible rise above, and/or depression below, the surface shall always be stated.



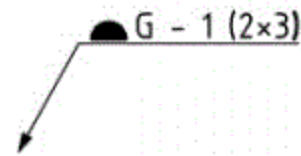
Figure 10 — Example of tool marking symbol

If it is necessary to specify the maximum permissible area, this area shall be indicated in brackets after the value of the maximum permissible rise above, and/or depression below the surface, i.e.:

- as a diameter on the surface of the moulded part [Figure 11 a)] by one value or
- by two values representing the dimensions of a rectangle on the surface of the moulded part [Figure 11 b)] where the first value represents the direction in the plane of the drawing and the second value represents the direction orthogonal to the plane of the drawing.



a) As a diameter



b) As a rectangle

Figure 11 — Example of tool marking symbols used with specification of maximum permissible area and deflection area

Values for maximum permissible flash can be specified on the right hand side of the graphical symbol for tool marking below the reference line, see 6.5 and Figure 12.

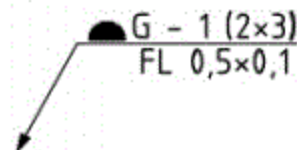


Figure 12 — Example of indication of permissible limit of flash at an ejector marking

The location of tool markings on the surface of a moulded part shall be indicated and toleranced in accordance with ISO 1101.

6.3 Special ejector markings identifier

If necessary for recognition purposes, the ejector markings shall be specifically indicated on the drawing. The graphical symbol shown in Figure 13 shall be used. For details of the symbol, see Figure A.4.



Figure 13 — Graphical symbol for identifying ejector marking

The special graphical symbol for identifying ejector marking may be used together with the tool marking symbol for specifying maximum permissible elevation and or depression as shown in Figure 14.

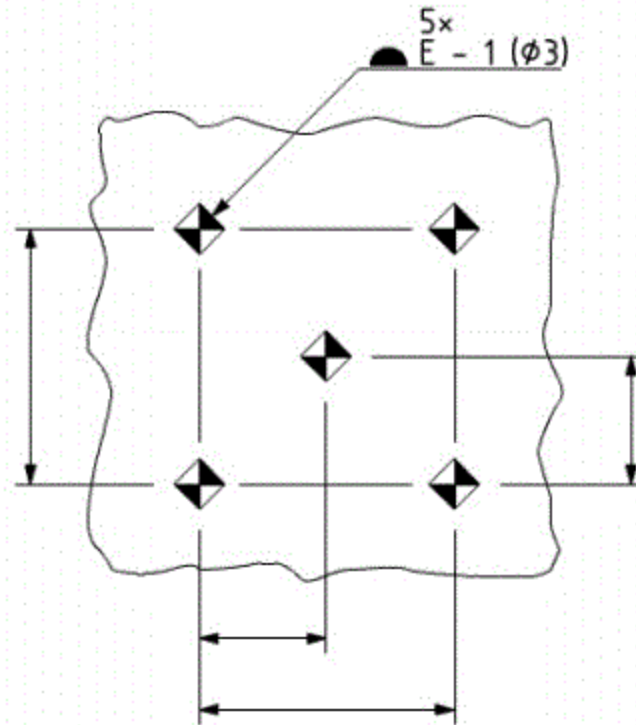


Figure 14 — Example of the use of the special ejector markings identifier together with the tool marking symbol

6.4 Mismatch

6.4.1 General

Surface mismatch may appear on real features and is formed by more than one mould component at the location where the parting surface intersects the features. Surface mismatch may be generated e.g. by a main parting surface, a slider, a tooling insert or a parting surface between two mating cores etc.

Examples of surface mismatch caused by dimensional, linear and rotational mismatch are given in Figures 15, 16 and 17 respectively.

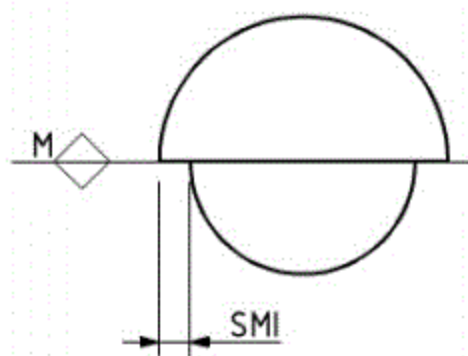
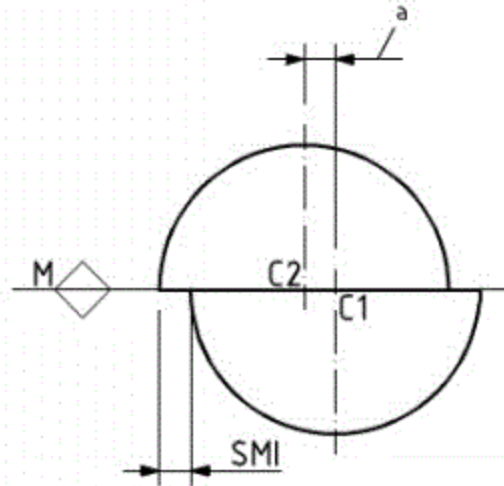
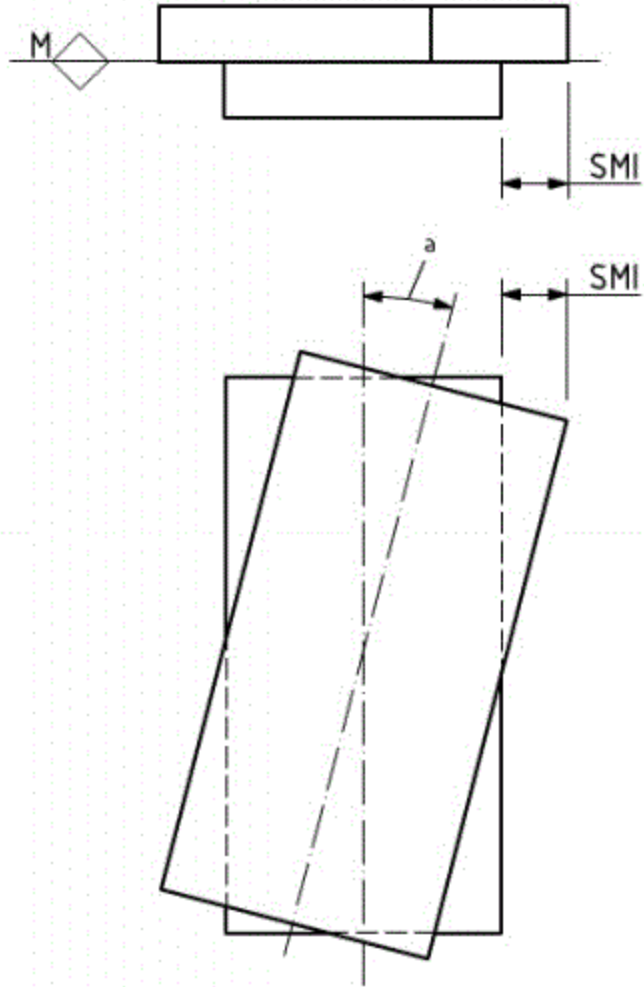


Figure 15 — Surface mismatch (SMI) caused by dimensional mismatch between two mating mould components



a Linear mismatch.

Figure 16 — Surface mismatch caused by linear mismatch between two mating mould components



a Rotational mismatch.

Figure 17 — Surface mismatch caused by rotational mismatch between two mating mould components

Since mismatch is an undesirable product of a moulding process, it may be necessary to control its appearance by specifying the maximum permissible surface mismatch.

6.4.2 Maximum permissible surface mismatch, SMI

6.4.2.1 General

If it is necessary to specify the maximum permissible surface mismatch, the graphical letter symbol shown in Figure 18 shall be indicated.

SMI

Figure 18 — Graphical letter symbol for maximum permissible surface mismatch

Reproduction of this document is prohibited without the written permission of ISO.

The value of the maximum permissible surface mismatch shall be given with a sign as shown in Table 5 and in Figure 19 specifying the permissible direction in relation to the corresponding part of the feature to which the graphical letter symbol is indicated, see Figures 20 and 21:

Table 5 — Sign for SMI

+	(plus)	elevation
-	(minus)	depression
±	(plus-minus)	elevation and/or depression

SMI ±0,2

Figure 19 — Example of an indication of maximum permissible surface mismatch

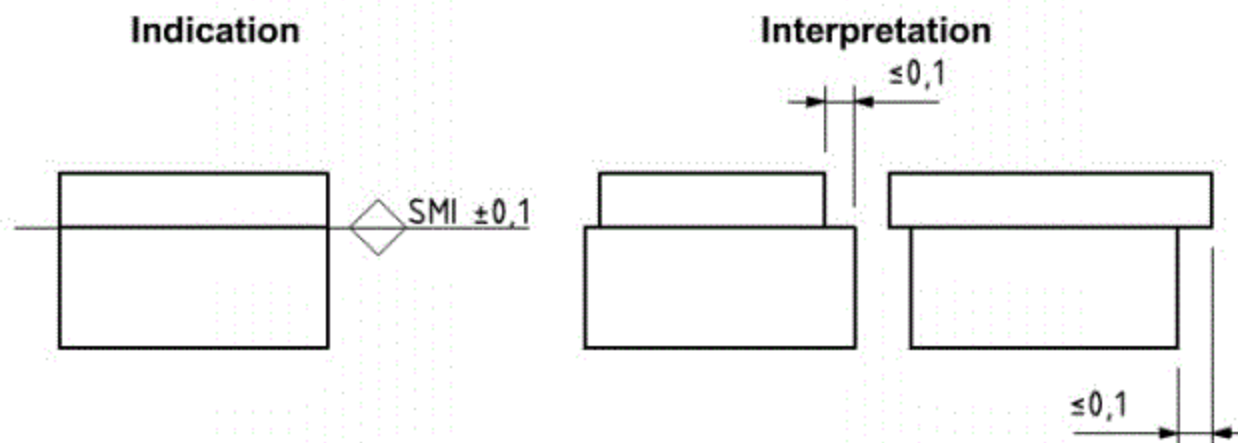
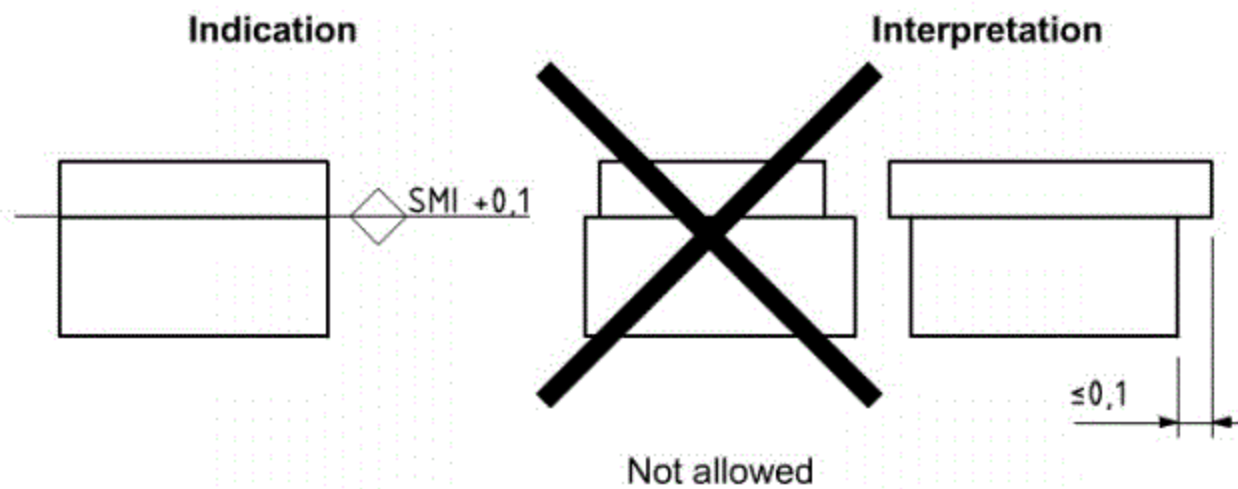


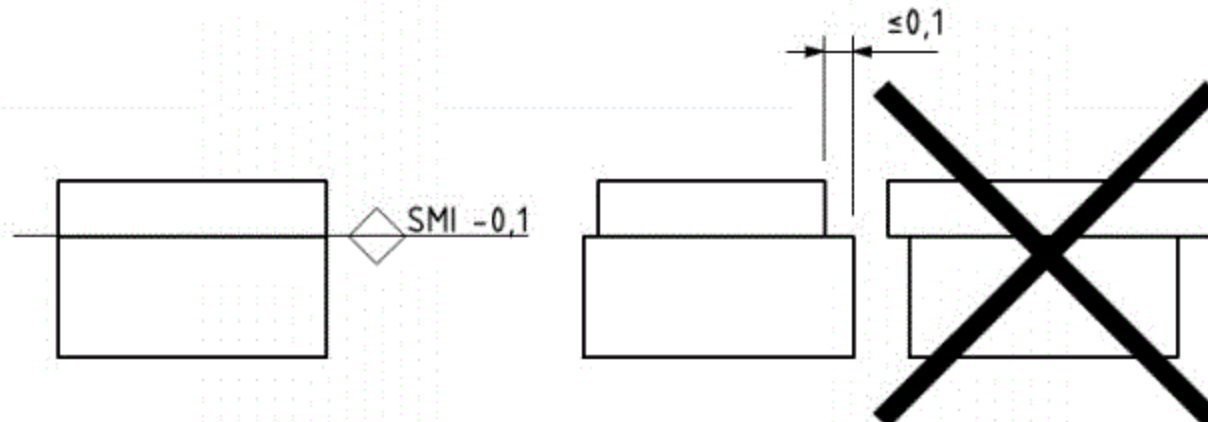
Figure 20 — Permissible surface mismatch (SMI) between two mating mould components when specified with ± sign on the upper mould component



a) Permissible surface mismatch with + (plus) sign

Indication

Interpretation



b) Permissible surface mismatch with - (minus) sign

Figure 21 — Permissible surface mismatch (SMI) between two mating mould components when specified on the upper mould component

Maximum permissible surface mismatch may be indicated as:

- global SMI specification, see 6.4.2.2;
- individual SMI specification, see 6.4.2.3.

6.4.2.2 Global SMI specification

Global requirement for maximum permissible surface mismatch for all features intersected by a parting surface is specified on the right hand side of the graphical symbol for the parting line and physically located above the parting line, see Figure 22.



Figure 22 — Graphical symbol for global requirement of mismatch

In the case where more than one graphical symbol is used on a drawing to illustrate a single parting surface, the global specification for maximum permissible surface mismatch shall be stated after one of the graphical symbols only, see Figure 23.

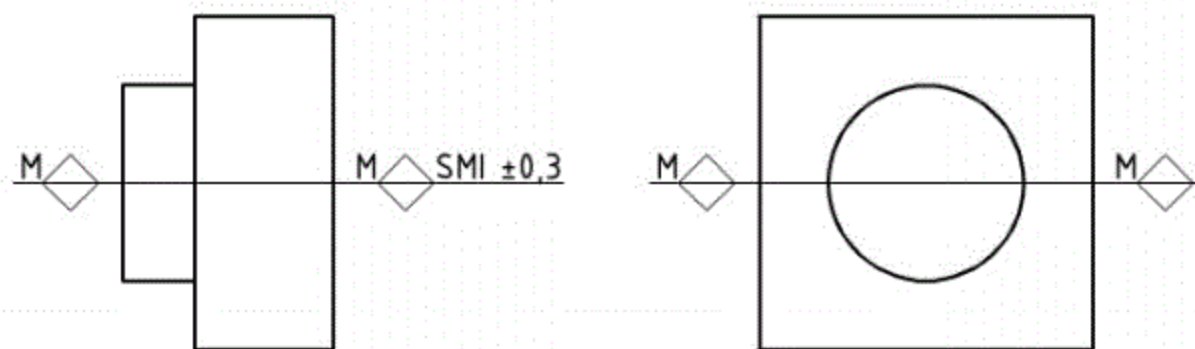


Figure 23 — Example of the Indication of global requirement of surface mismatch

6.4.2.3 Individual SMI specification

The requirement for maximum permissible surface mismatch on individual features is indicated on a reference line in accordance with ISO 128-22 (see Figures 24 and 25)

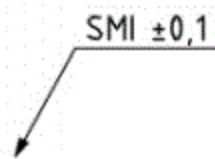


Figure 24 — Graphical letter symbol for indication of maximum permissible surface mismatch used with leader and reference lines

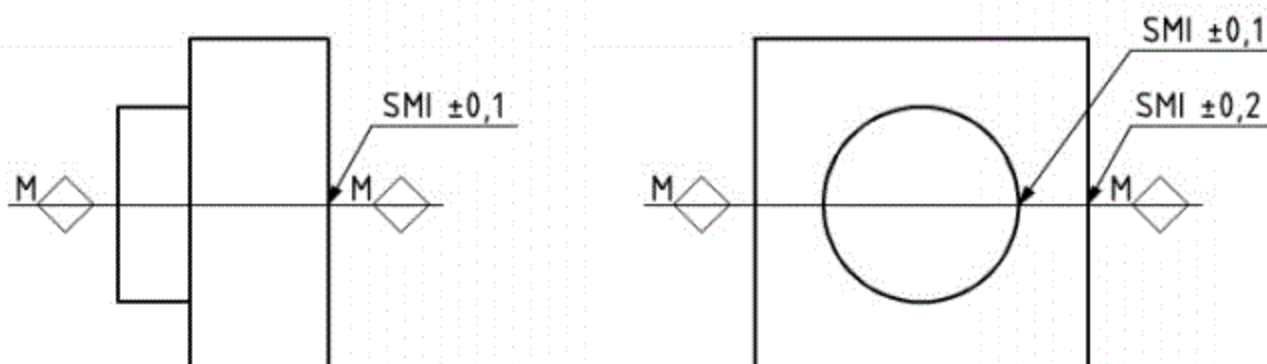


Figure 25 — Example of surface mismatch at individual features

A specification of an individual requirement for maximum permissible surface mismatch overrides a specification for a global requirement for maximum permissible surface mismatch.

6.5 Flash

6.5.1 General

Since flash usually is an undesirable product of a moulding process, it may be necessary to control its appearance by specifying the maximum permissible flash and/or the flash-free areas.

6.5.2 Maximum permissible flash dimension

6.5.2.1 General

If it is necessary to specify the maximum permissible flash dimension, the graphical letter symbol shown in Figure 26 shall be indicated.

FL

Figure 26 — Graphical letter symbol for indication of maximum permissible flash

The maximum permissible flash dimensions shall be specified on the right hand side of the graphical letter symbol either as one or two numerical values (see e.g. Figures 27 and 28).

FL 0,2

Figure 27 — Example of a specification of maximum permissible flash height

FL 0,2×0,05

Figure 28 — Example of a specification of maximum permissible flash height and width

The first value represents the maximum permissible height of the flash and the second value, if any, represents the maximum permissible width of the flash, see Figure 29.

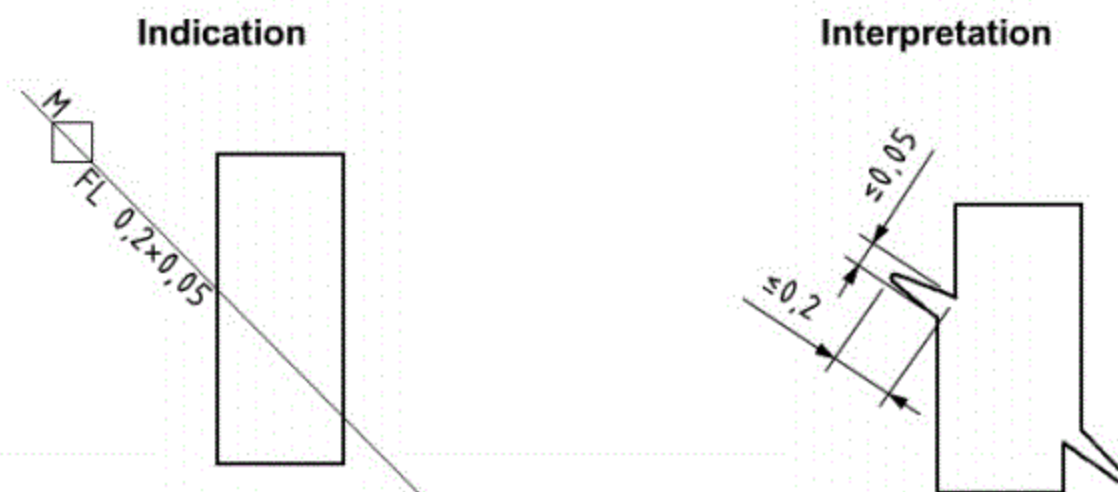


Figure 29 — Example of the interpretation of flash requirement

The maximum permissible flash dimensions may be specified as:

- global flash specification, see 6.5.2.2;
- individual flash specification, see 6.5.2.3.

6.5.2.2 Global flash Specification

Global requirement for maximum permissible flash dimensions for all features intersected by a parting surface is specified on the right hand side of the graphical symbol for the parting line and physically located below the parting line, see Figure 30.

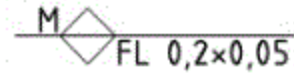


Figure 30 — Graphical symbol for indication of global requirement of flash

In the case where more than one graphical symbol is used on a drawing to illustrate a single parting surface, the global requirement for maximum permissible flash dimensions shall be stated after one of the graphical symbols only, see Figure 31.



Figure 31 — Example of an indication of global requirement of flash

6.5.2.3 Individual flash specification

The requirement for maximum permissible flash dimensions on individual features is indicated on a reference line in accordance with ISO 128-22 (see Figures 32 and 33).

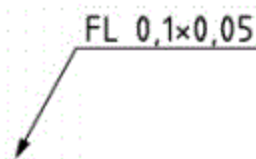


Figure 32 — Example of graphical letter symbol for indication of maximum permissible flash dimension used with leader and reference lines

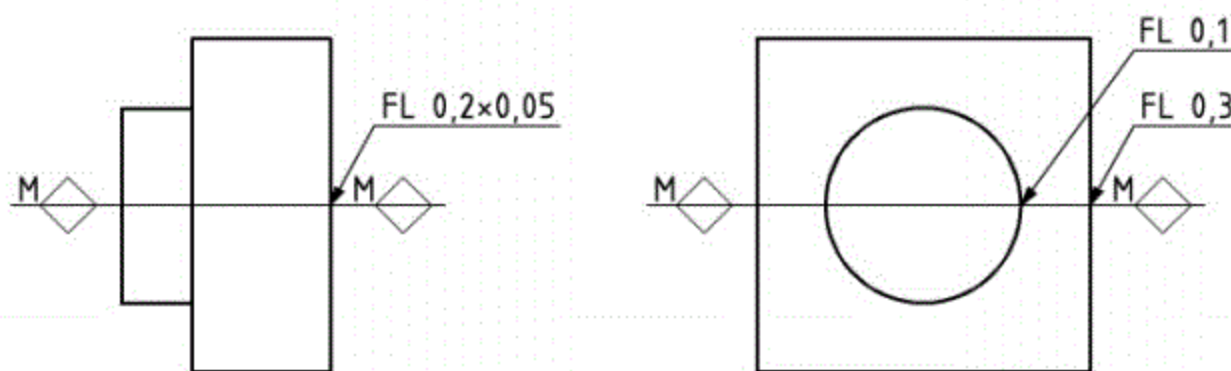


Figure 33 — Example of indication of flash at individual features

Maximum permissible flash may be specified under the same reference line as a specification of maximum permissible surface mismatch, see Figure 34.

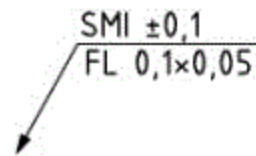


Figure 34 — Example of graphical symbol for indication of maximum permissible surface mismatch and flash dimensions used with leader and reference lines

A specification of an individual maximum permissible flash overrides a specification for a global maximum permissible flash.

6.5.3 Flash-free area or length

If it is necessary to indicate that no flash may be present on a surface, the graphical letter symbol shown in Figure 35 shall be indicated.

FLF

Figure 35 — Graphical letter symbol for flash-free condition

The graphical letter symbol for the flash-free condition is indicated on a reference line in accordance with ISO 128-22 (see Figure 36).



Figure 36 — Indication of flash-free condition used with leader and reference lines

6.6 Extent of specification

6.6.1 General

Sometimes specifications or special conditions restricted to limited areas, apply to more than one feature, section of a workpiece or the whole workpiece.

6.6.2 Restricted area

If it is necessary to indicate a specific restricted area or length of a surface of a feature or a combination of adjoined features, then the area or length and its location are indicated by a long-dashed dotted wide line, drawn adjacent and parallel to the surface and at a short distance from it.

If the requirement is applied to a feature of revolution, the indication shall be shown on one side only (see Figure 37). However, when the drawing clearly shows the extent of the indication, dimensioning is not necessary, see Figure 38.

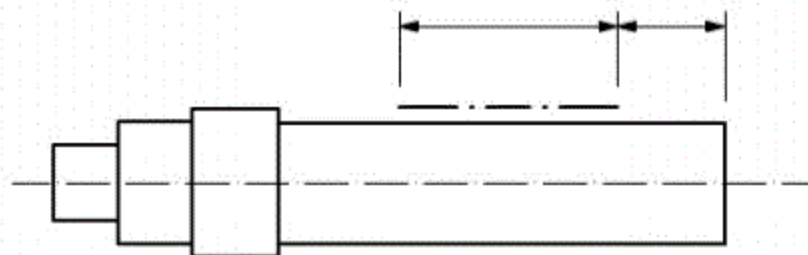


Figure 37 — Indication of restricted area of a feature

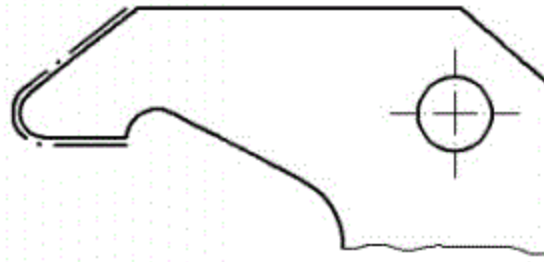


Figure 38 — Indication of a combination of adjoined features

Leader lines used for indicating requirements that apply only at the restricted area shall be terminated in accordance with ISO 128-22 (see Figures 39 and 40).

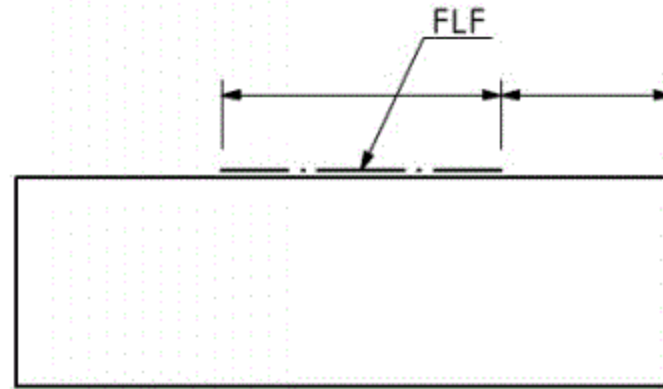


Figure 39 — Indication of flash-free area on a restricted area of a feature (side elevation)

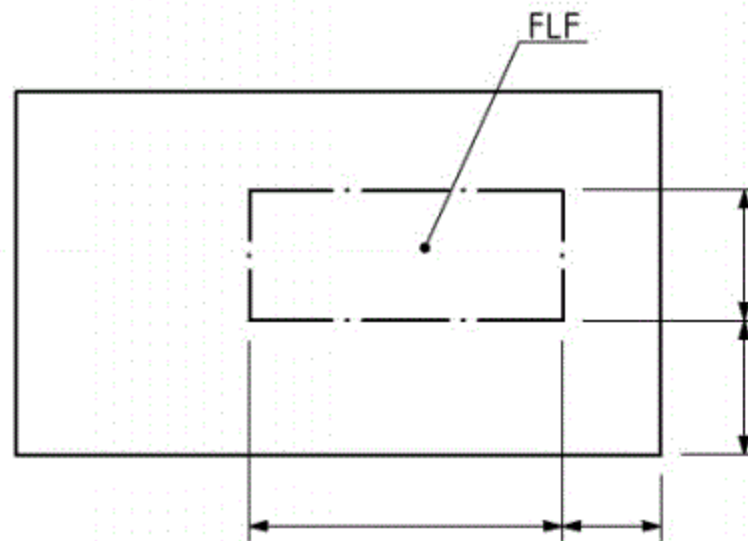


Figure 40 — Indication of flash-free area on a restricted area of a feature (plan)

6.6.3 Extended region

6.6.3.1 General

If it is necessary to specify the same requirement for several features that are connected to each other all the way around the workpiece, it can be done by one of the variations of indication of extended region of a part (see Table 6). For details of the symbols, see Figures A.12 to A.15.

Table 6 — Types of variation for indicating an extended region of a part

Sub-type	Variations of indication of extended region of a part					
	All around		All about		All over	
Global		see 6.6.3.2		see 6.6.3.4		see 6.6.3.6
Partial		see 6.6.3.3		see 6.6.3.5		see 6.6.3.7

6.6.3.2 Global all around

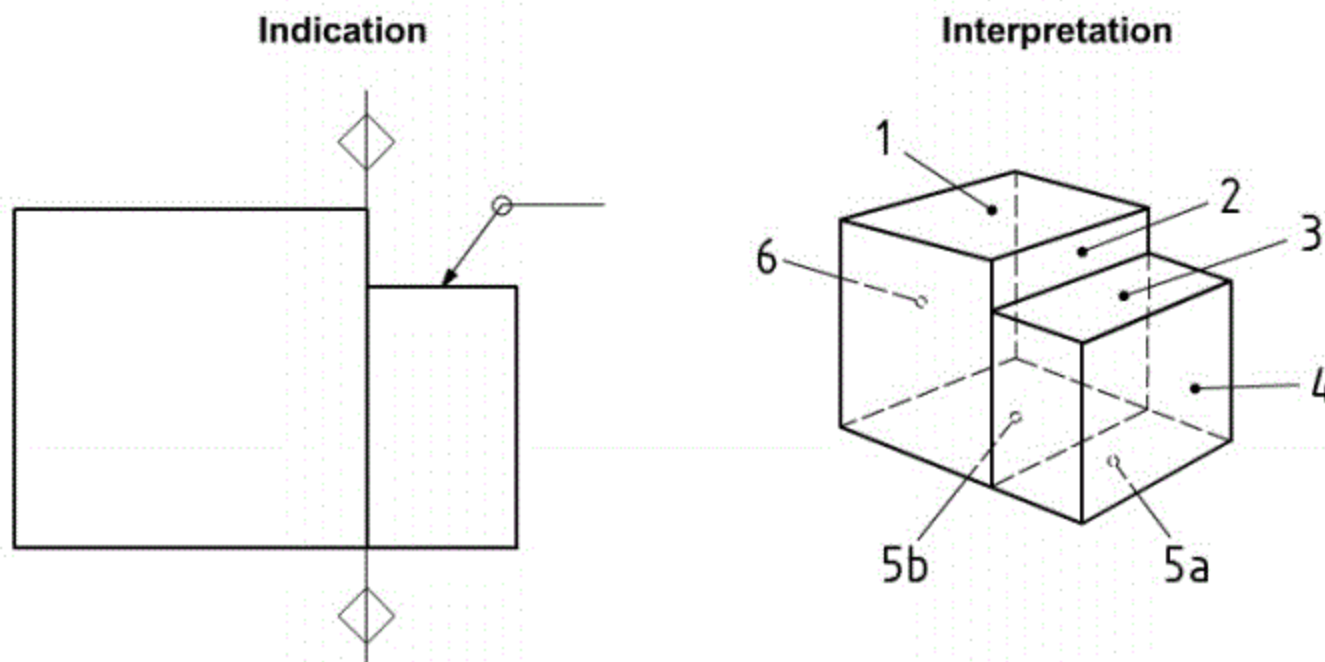
If it is necessary to apply a requirement to all features represented by a closed outline on a view on the drawing regardless of potential intersecting parting surfaces, the graphical symbol for global all around shown in Figure 41 shall be indicated at the intersection point between the leader and reference line as shown in Figure 42. An example of the application of the symbol is given in Figure 43.



Figure 41 — Graphical symbol for global all around



Figure 42 — Graphical symbol for indication of global all around condition used on leader and reference lines



NOTE The requirement indicated applies to the surfaces 1 to 6.

Figure 43 — Global all around used on leader and reference lines

6.6.3.3 Partial all around

If it is necessary to apply a requirement to all features related to a specific shaping mould component represented by a continuous outline on a view on the drawing, the graphical symbol for partial all around shown in Figure 44 shall be indicated at the intersection point between the leader and reference line as shown in Figure 45. An example of the application of the symbol is given in Figure 46.



Figure 44 — Graphical symbol for partial all around

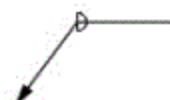
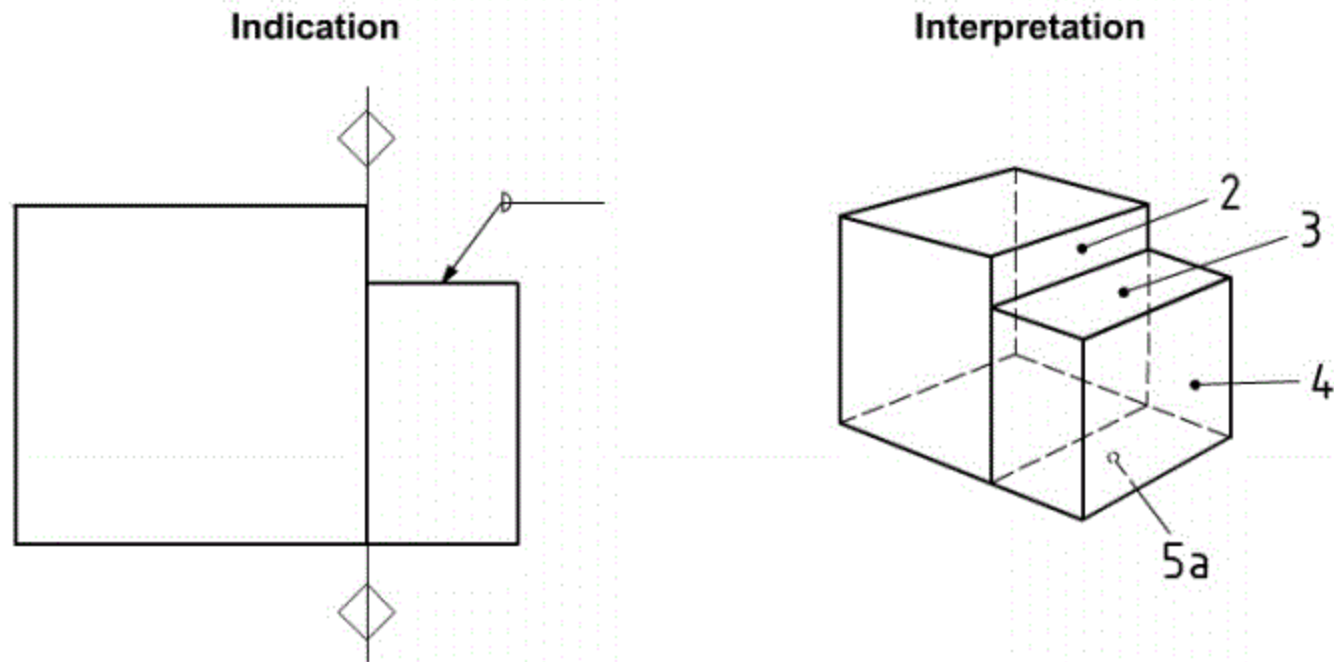


Figure 45 — Graphical symbol for indication of partial all around condition used on leader and reference lines



NOTE The requirement indicated applies to the surfaces 2 to 5a, which are moulded by the same shaping mould component.

Figure 46 — Partial all around symbol used on leader and reference lines

6.6.3.4 Global all about

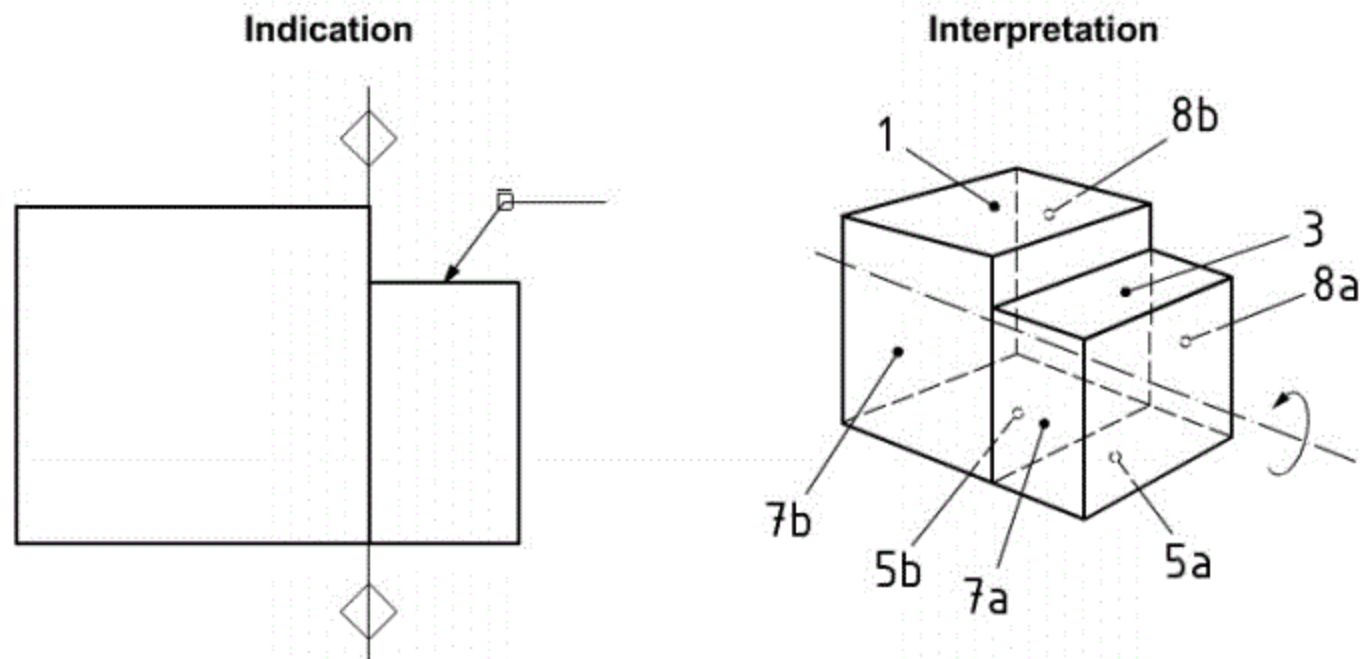
If it is necessary to apply a requirement to all features around a part which all are parallel to a horizontal or vertical axis in the plane of projection for the actual view on the drawing, regardless of potential intersecting parting surfaces, the basic graphical symbol for global all about, shown in Figure 47, shall be indicated at the intersection point between the leader and reference line together with an horizontal or vertical axis indicator as shown in Figure 48. An axis indicator shall always be indicated next to the basic graphical symbol for global all about. An example of the application of the symbol is given in Figures 49 and 50.



Figure 47 — Basic graphical symbol for global all about

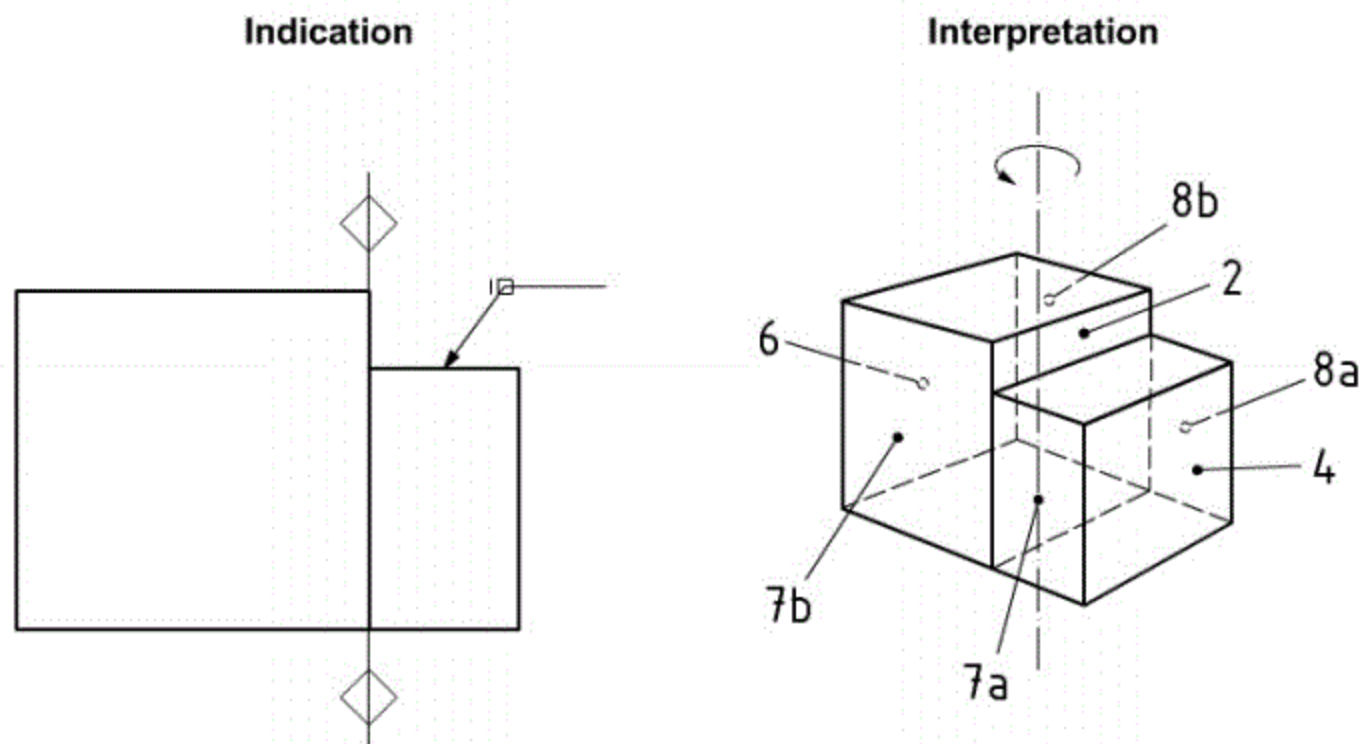


Figure 48 — Graphical symbol for indication of global all about condition used on leader and reference lines



NOTE The requirement indicated applies to the surfaces 1, 3, 5a, 5b, 7a, 7b, 8a and 8b.

Figure 49 — Global all about symbol on leader and reference lines used with horizontal axis indicator



NOTE The requirement indicated applies to the surfaces 2, 4, 6, 7a, 7b, 8a and 8b.

Figure 50 — Global all about symbol on leader and reference lines used with vertical axis indicator

6.6.3.5 Partial all about

If it is necessary to apply a requirement to all features partially around a part which all are parallel to a horizontal or vertical axis in the plane of projection for the actual view on the drawing and limited by the relevant shaping mould component, the basic graphical symbol for partial all about shown in Figure 51 shall be indicated at the intersection point between the leader and reference line together with an horizontal or vertical axis indicator as shown in Figure 52. An axis indicator shall always be indicated next to the basic graphical symbol for partial all about. An example of the application of the symbol is given in Figures 53 and 54.



a) With horizontal axis indicator

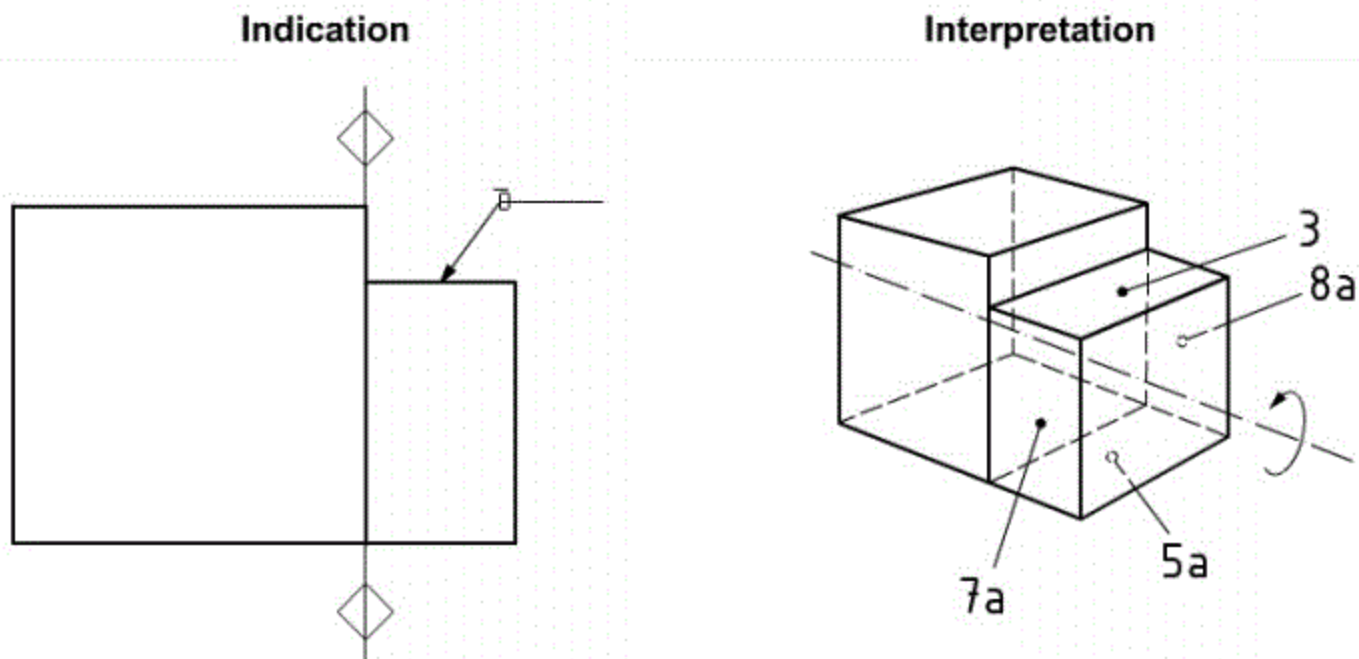


b) With vertical axis indicator

Figure 51 — Basic graphical symbol for partial all about

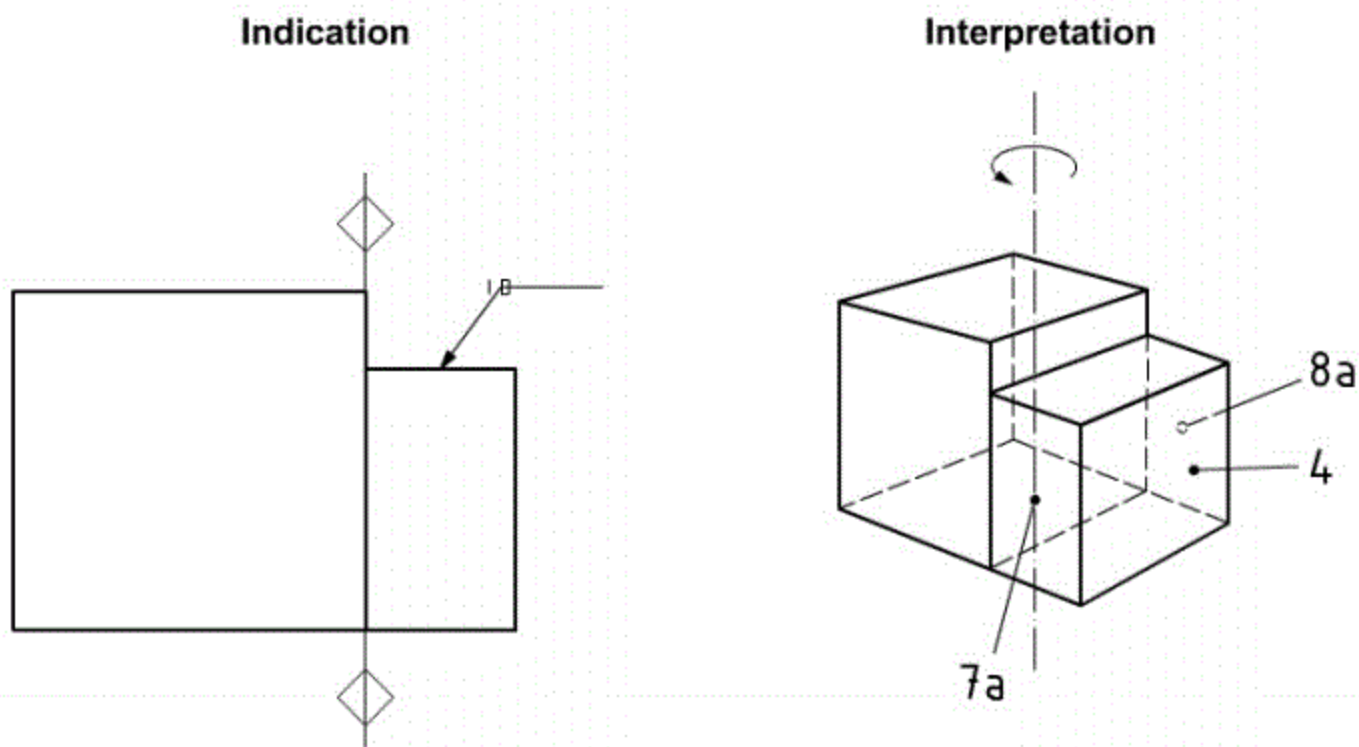


Figure 52 — Graphical symbol for indication of partial all about condition used on leader and reference lines



NOTE The requirement indicated applies to the surfaces 3, 5a, 7a and 8a.

Figure 53 — Partial all about symbol on leader and reference lines used with horizontal axis indicator



NOTE The requirement indicated applies to the surfaces 4, 7a and 8a.

Figure 54 — Partial all about symbol on leader and reference lines used with vertical axis indicator

6.6.3.6 Global all over

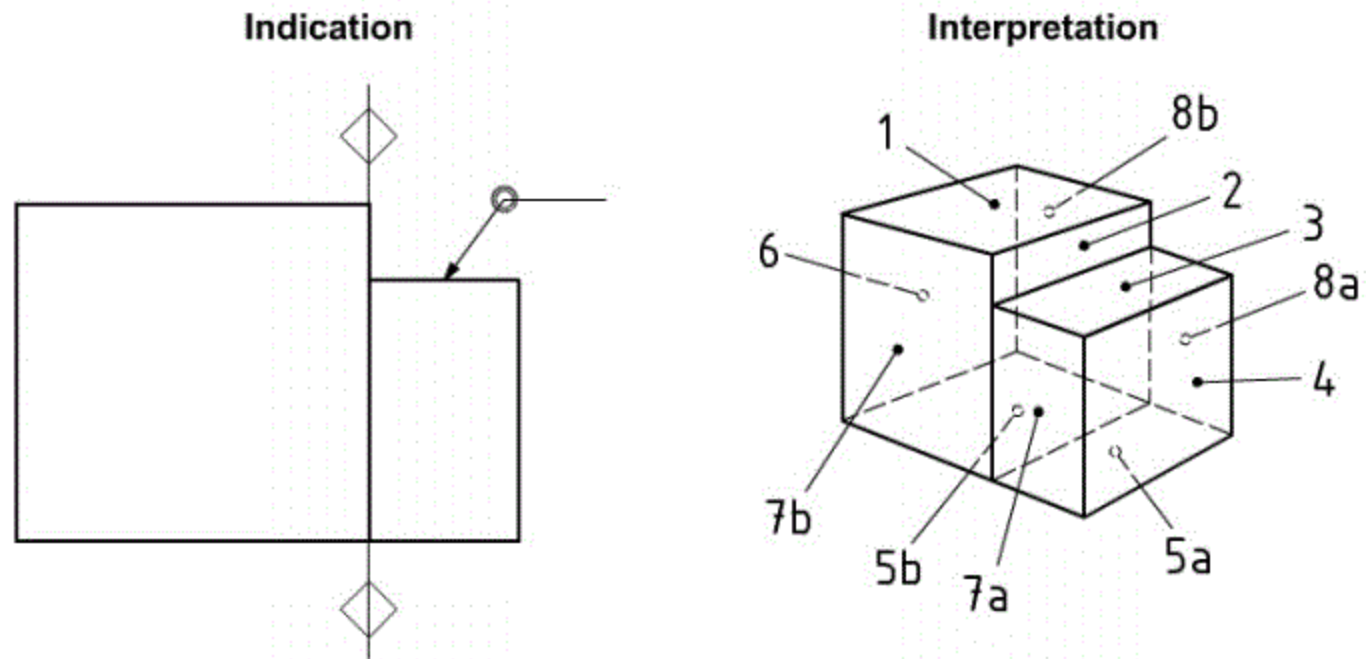
If it is necessary to apply a requirement to all features on a part regardless of intersecting parting surfaces, the graphical symbol for global all over shown in Figure 55 shall be indicated at the intersection point between the leader and reference line as shown in Figure 56. An example of the application of the symbol is given in Figure 57.



Figure 55 — Graphical symbol for global all over



Figure 56 — Graphical symbol for indication of global all over condition used on leader and reference lines



NOTE The requirement indicated applies to the surfaces 1, 2, 3, 4, 5a, 5b, 6, 7a, 7b, 8a and 8b.

Figure 57 — Global all over symbol used on leader and reference lines

6.6.3.7 Partial all over

If it is necessary to apply a requirement to all features limited between one or two intersecting parting surfaces on a part, the graphical symbol for partial all over shown in Figure 58 shall be indicated at the intersection point between the leader and reference line as shown in Figure 59. An example of the application of the symbol is given in Figure 60.



Figure 58 — Graphical symbol for indication of partial all over

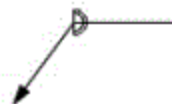
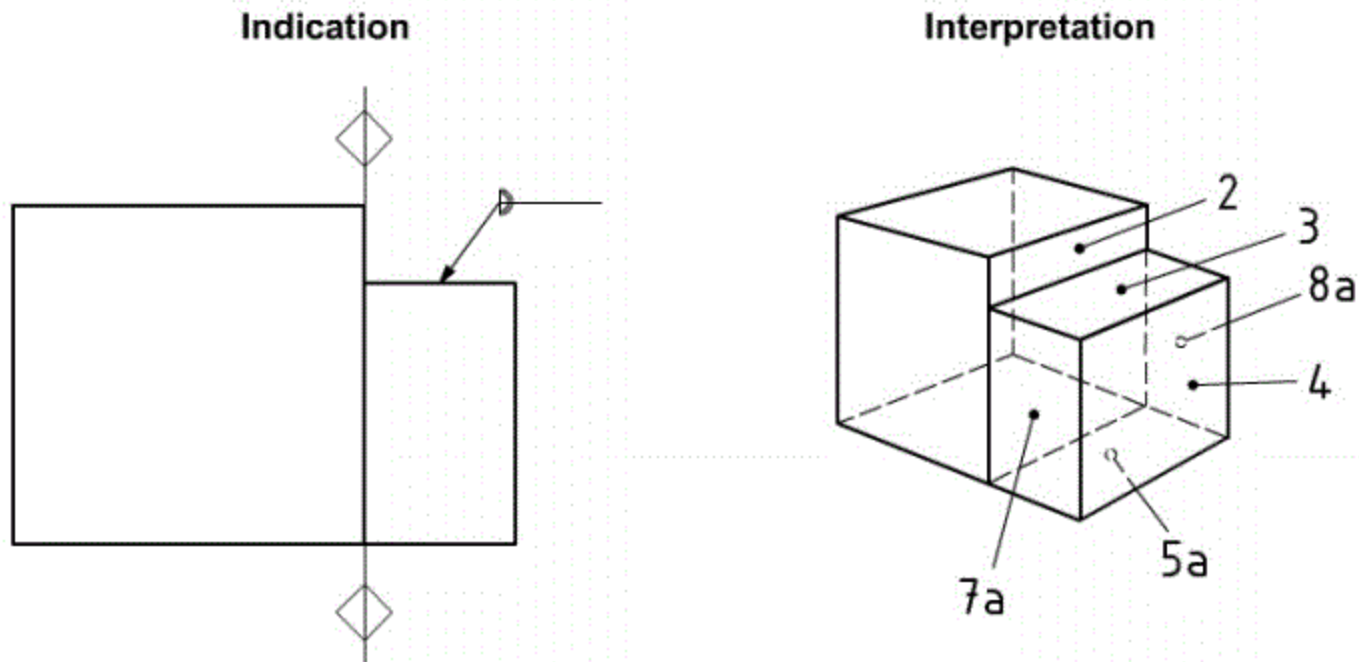


Figure 59 — Graphical symbol for indication of partial all over condition used on leader and reference lines



NOTE The requirement indicated applies to the surfaces 2, 3, 4, 5a, 7a and 8a.

Figure 60 — Partial all over symbol used on leader and reference lines

6.7 Draft angles

6.7.1 General

The draft angle of a surface of a moulded part shall be indicated on the drawing by the position of a graphical inclination symbol. The inclination symbol can be either a single inclination symbol or a combined inclination symbol (see Figure 61). For details of the symbol, see Figures A.5 to A.11.

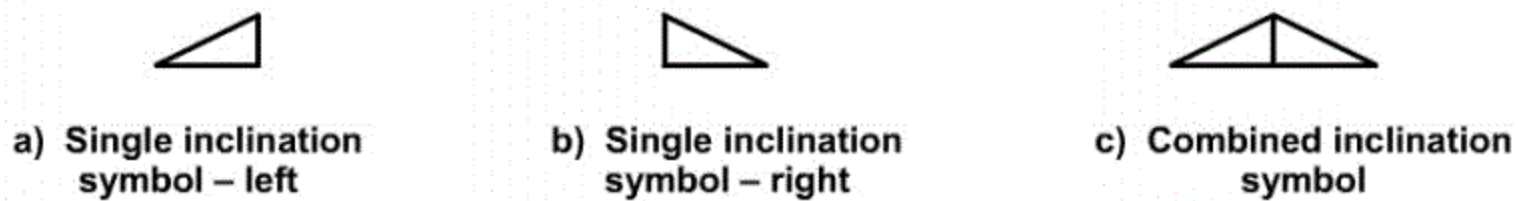


Figure 61 — Graphical symbol for representing draft angles

6.7.2 Single inclination symbol

The single inclination symbol [see Figure 61 a) and b)] is indicated on a reference line in accordance with ISO 128-22 (see Figure 62).



Figure 62 — Inclination symbol used with leader and reference lines

The single inclination symbol is applied according to the following basic rules.

- Rule 1** The hypotenuses of the inclination symbol define the orientation of the draft angle.
- Rule 2** The longest leg (cathetus) of the inclination symbol shall be parallel to and be orientated toward the dimensioned feature.
- Rule 3** The size of the inclination shall be indicated in terms of the corresponding angle (e.g. 2°) or ratio (e.g. 1:10) and shall be applied on the right hand side of the inclination symbol.
- Rule 4** The arrowhead of the leader line identifies the edge at which the stated nominal dimension applies.

Rule 5 If the feature is intersected by a parting surface the draft applies only to the part of the feature which is limited by the edge identified by the arrowhead of the leader line and the parting surface (parting line). Otherwise the draft applies to the full extent of the feature.

Figures 63 and 64 illustrate examples of the application of the basic rules.

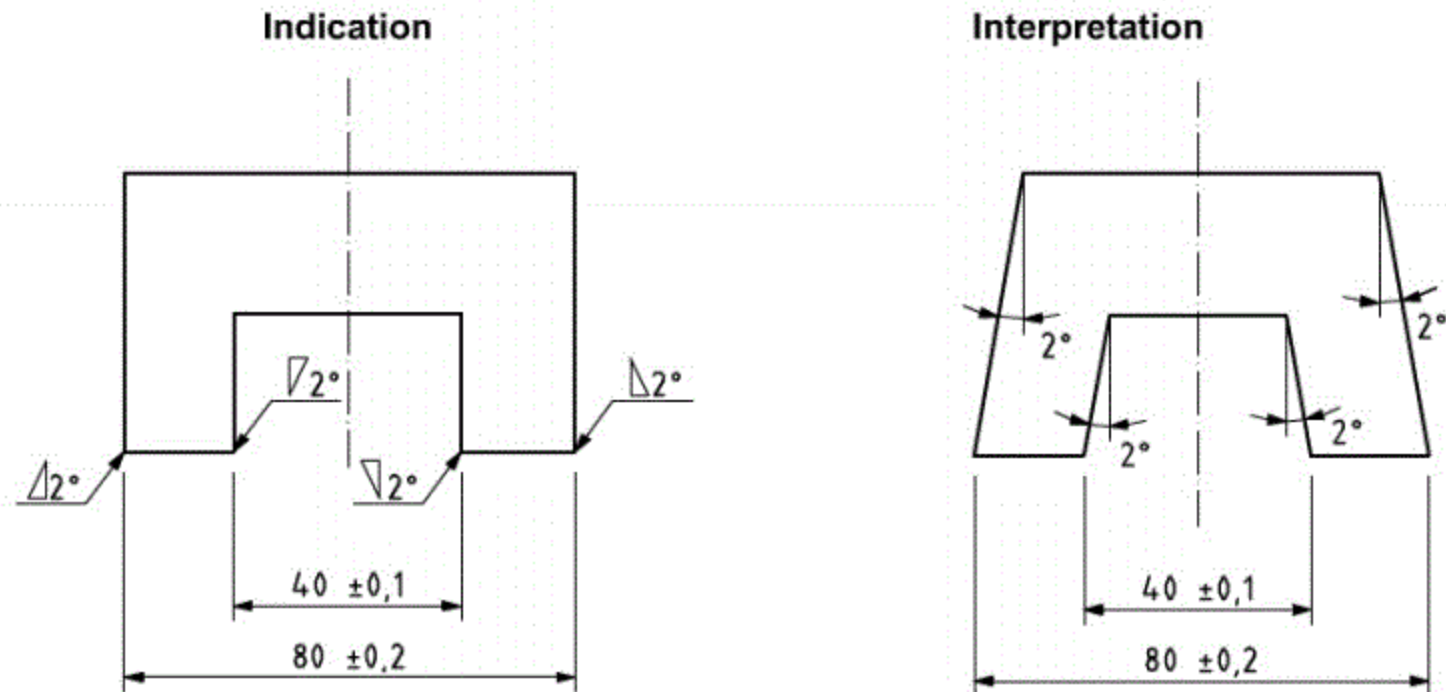


Figure 63 — Draft resulting from use of single inclination symbols (1st example)

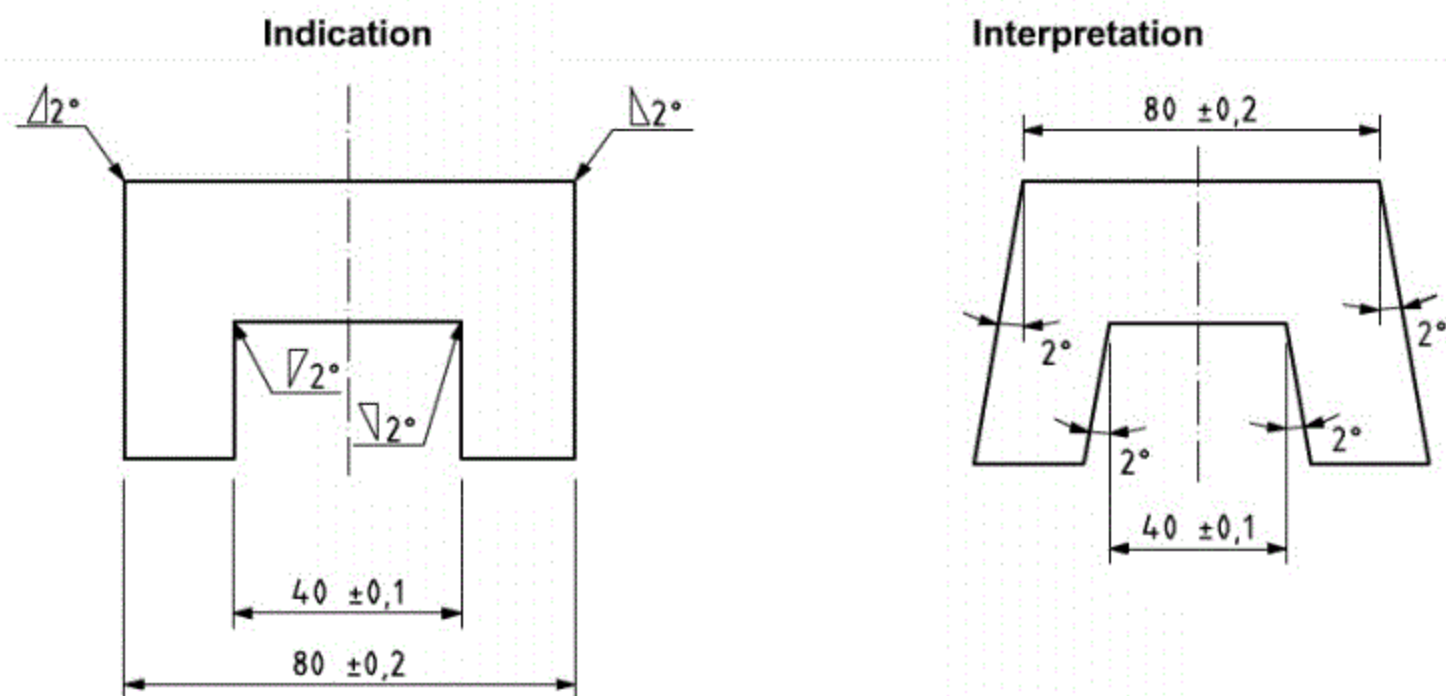


Figure 64 — Draft resulting from use of single inclination symbols (2nd example)

If the nominal dimension applies to a specific location/section on the dimensioned feature the following additional rule shall be applied.

Rule 6 The arrowhead of the leader line shall identify the exact location/section by application of a dimension (see Figure 65).

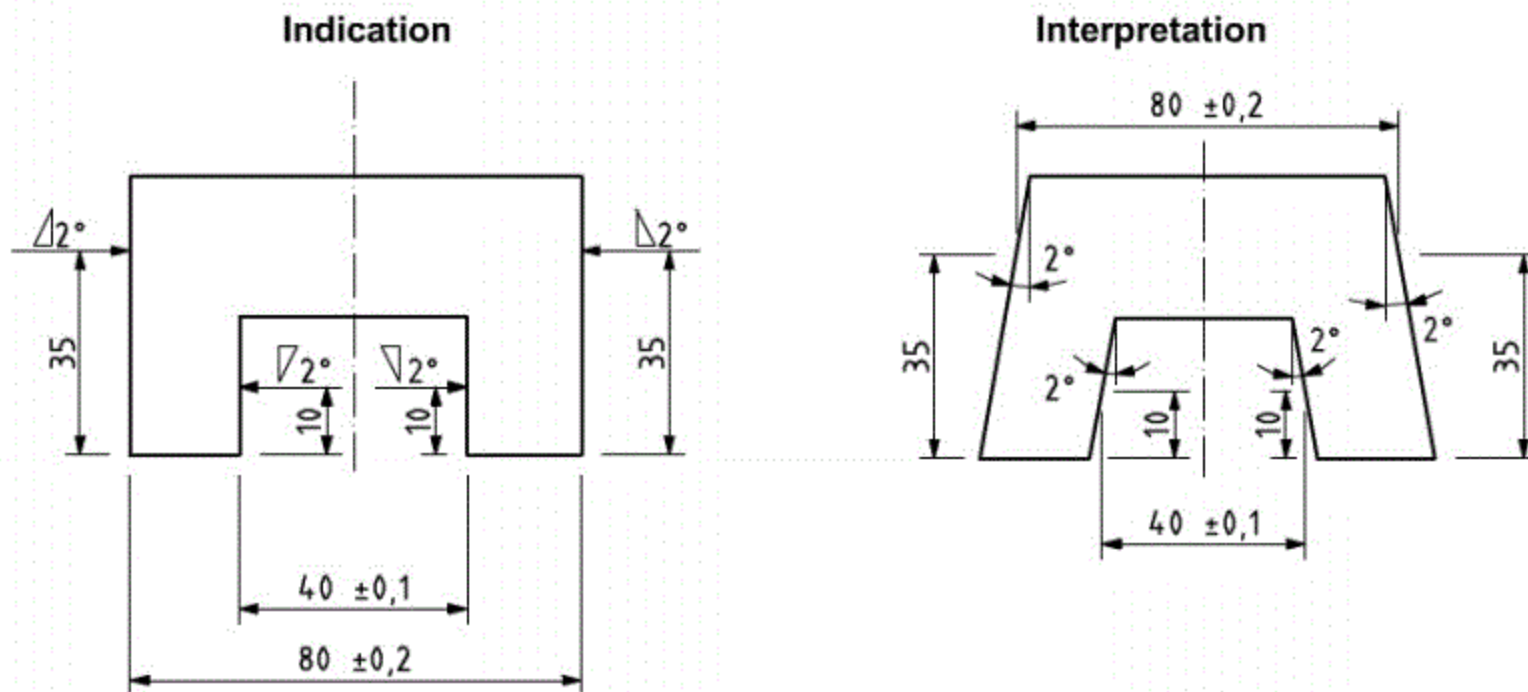


Figure 65 — Draft resulting from use of single inclination symbols at exact locations

6.7.3 Combined inclination symbol on the parting line

The combined inclination symbol [see Figure 61 c)] shall be indicated on a parting line. It shall be clearly specified whether the taper shall be added to (TP) or subtracted from (TM) the material.

The combined inclination symbol is applied according to the following basic rules:

- Rule 7** The hypotenuses of each single inclination symbol in the combined symbol define the orientation of the draft angles.
- Rule 8** The longest leg (cathetus) of each single inclination symbol in the combined symbol shall be parallel to and be orientated toward the dimensioned feature.
- Rule 9** The shortest leg (cathetus) of each single inclination symbol in the combined symbol shall be positioned as a part of the parting line.
- Rule 10.1** In case of equally sized inclinations, the size of inclination shall be indicated at the right hand side of the combined inclination symbol in terms of the corresponding angles (e.g. 2°) or ratio (e.g. 1:10) either above or below the parting line, but only once, and followed by the symbols of either TP or TM:
 - Rule 10.1.1** in the case of TP, the nominal dimension applies at that edge of the feature which is located at the corresponding side of the indicated TP;
 - Rule 10.1.2** in the case of TM, the nominal dimension applies at the parting line.
- Rule 10.2** In the case of differently sized inclinations, the individual sizes of inclination shall be indicated on the relevant sides of the parting line. The indication of TP or TM shall be stated only in conjunction with one of the indicated sizes of inclination:
 - Rule 10.2.1** in the case of TM, the nominal dimension applies at the parting line;
 - Rule 10.2.2** in the case of TP, the nominal dimension applies at that edge of the feature which is located at the corresponding side of the indicated TP.

Figures 66, 67 and 68 illustrate examples of the application of the basic rules.

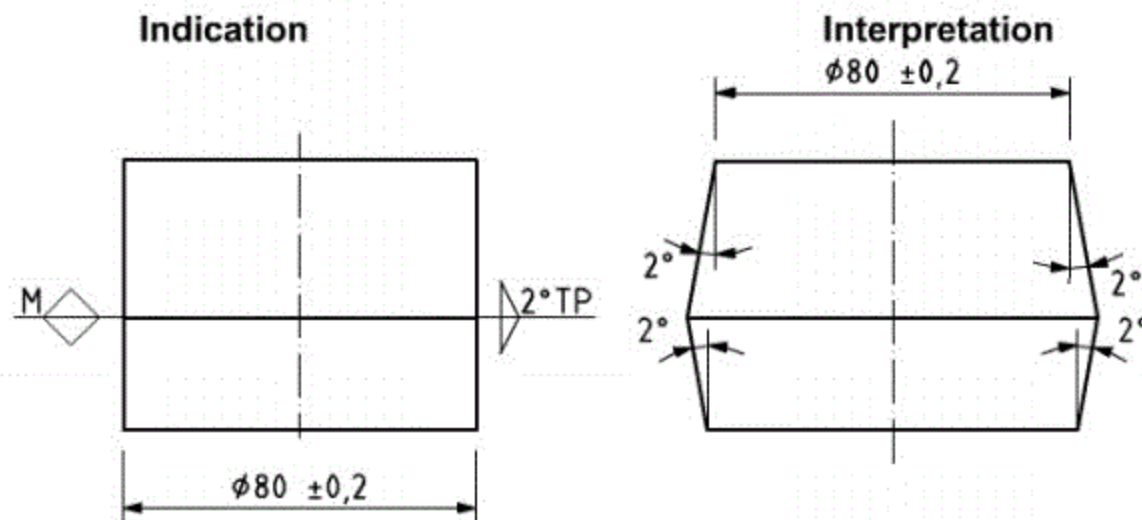


Figure 66 — Combined inclination with added taper (TP) (1st example)

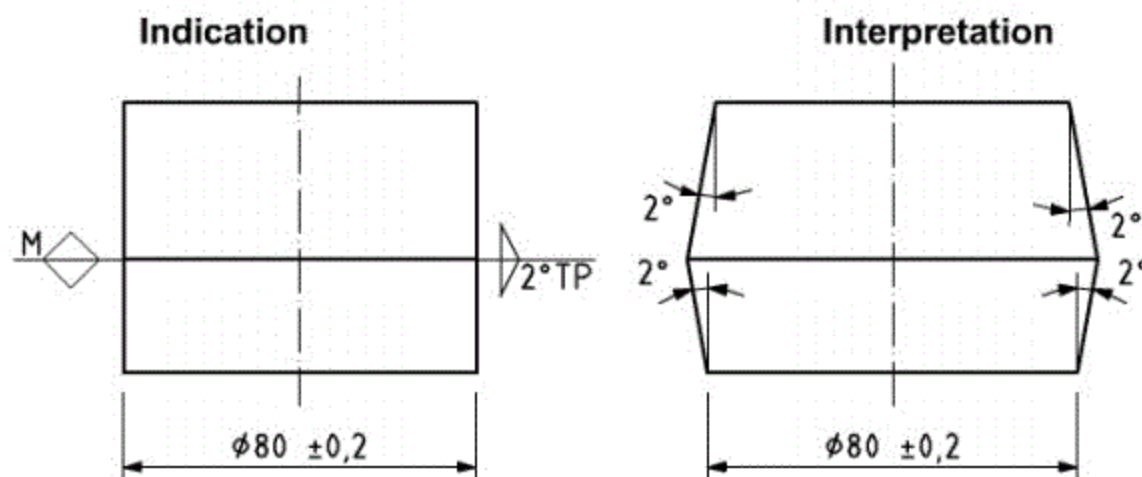


Figure 67 — Combined inclination with added taper (TP) (2nd example)

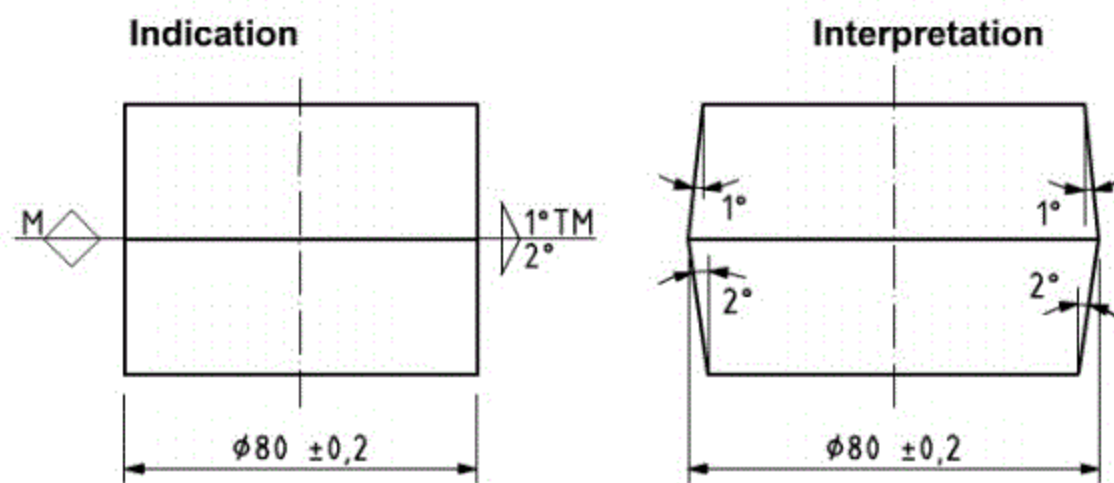


Figure 68 — Combined inclination with subtracted taper (TM)

6.7.4 Combined inclination symbol at a specified location

The arrowhead of the reference line shall identify the exact location/section by application of a dimension (see Figure 69). The combined inclination symbol [see Figure 61 c)] is indicated on a reference line. It shall be clearly specified whether the taper shall be added to (TP) or subtracted from (TM).

The combined inclination symbol is applied according to the following basic rules:

- Rule 11** The hypotenuses of each single inclination symbol in the combined symbol define the orientation of the draft angles.
- Rule 12** The longest legs (cathetus) of each single inclination symbol in the combined symbol shall be parallel to and be orientated toward the dimensioned feature.

Rule 13 The shortest legs (cathetus) of each single inclination symbol in the combined symbol shall be positioned as a part of the reference line.

Rule 14.1 In the case of equally sized inclinations, the size of inclination shall be indicated at the right hand side of the combined inclination symbol in terms of the corresponding angles (e.g. 2°) or ratio (e.g. 1:10) either above or below the reference line, but only once, and followed by the letter symbols of either TP or TM:

Rule 14.1.1 in the case of TM, the nominal dimension applies at the reference line;

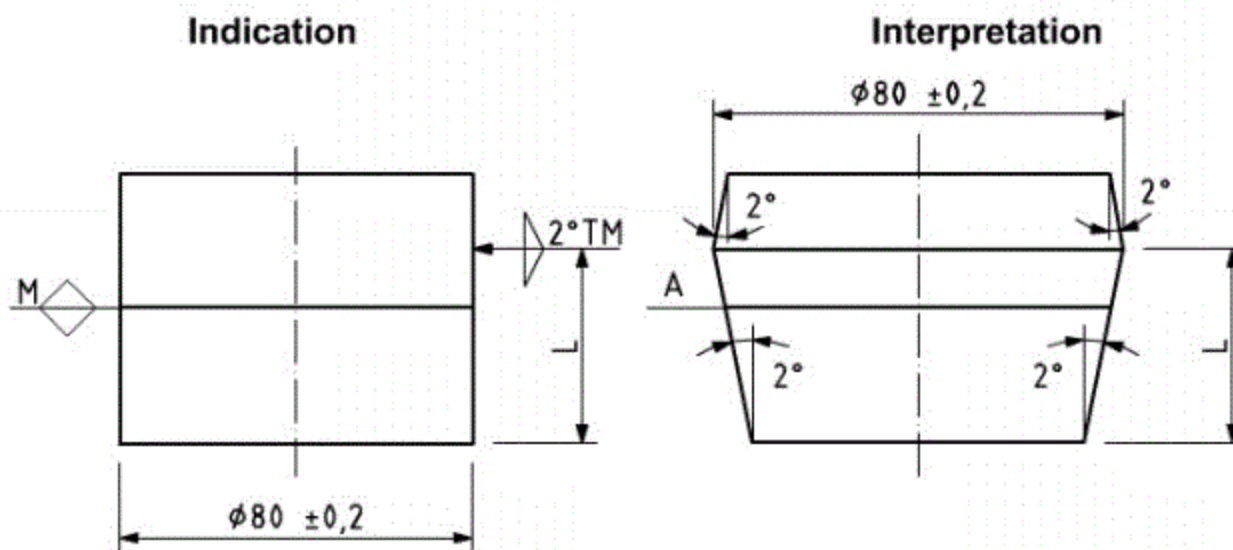
Rule 14.1.2 in the case of TP, the nominal dimension applies at that edge of the feature which is located at the corresponding side of the indicated TP.

Rule 14.2 In the case of differently sized inclinations, the individual sizes of inclination shall be indicated on the relevant sides of the reference line. The indication of TP or TM shall be stated only in conjunction with one of the indicated sizes of inclination:

Rule 14.2.1 in the case of TM, the nominal dimension applies at the reference line;

Rule 14.2.2 in the case of TP, the nominal dimension applies at that edge of the feature which is located at the corresponding side of the indicated TP.

Figure 69 illustrates examples of the application of the basic rules.



A is the parting surface.

Figure 69 — Indication and interpretation of combined inclination with subtracted taper (TM) at a specified location

6.7.5 Taper to fit

A draft (taper) to fit (TF) may be specified instead of a numerical value, see Figures 70, 71, 72 and 73 if the following applies:

- the maximum permissible surface mismatch (SMI) on the part is of importance;
- the taper of the part of a feature is dependent on another dimension of the part;
- the taper of the part of a feature is dependent on the location and orientation of the parting surface in order to achieve an acceptably small surface mismatch (SMI).

Taper to fit (TF) shall be specified together with a specification of maximum permissible surface mismatch, SMI.

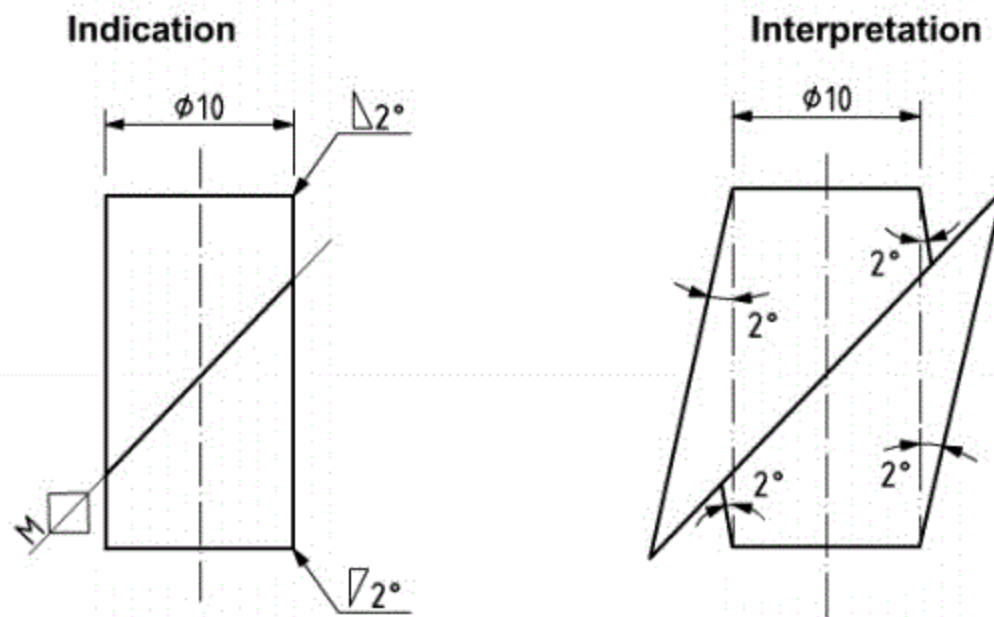


Figure 70 — Inclined parting surface on a part with a numerical specified draft

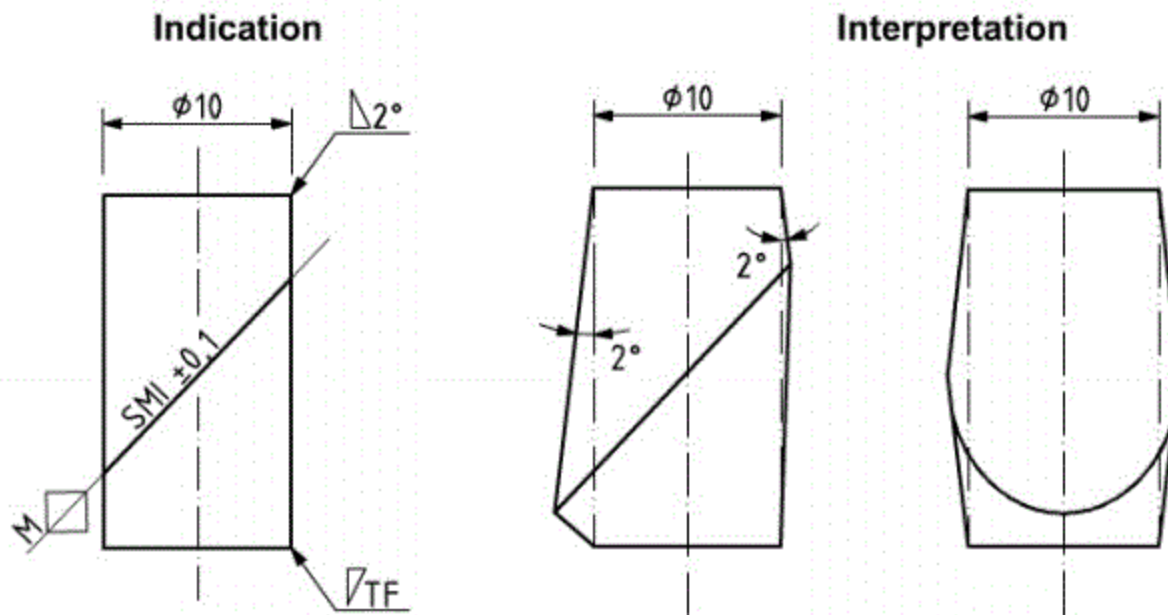


Figure 71 — Inclined parting surface on a part with a specification of taper to fit (TF)

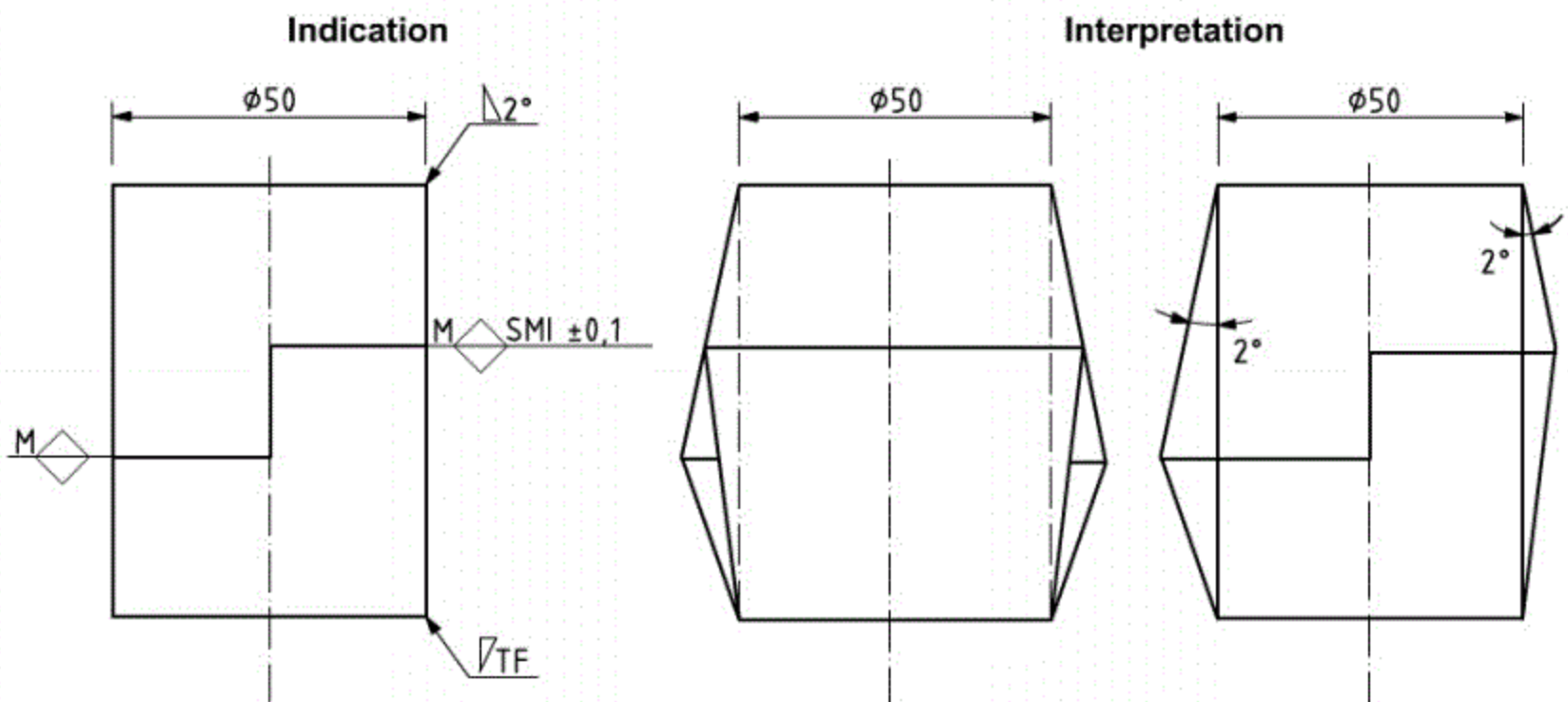


Figure 72 — Stepped parting surface on a part with a specification of taper to fit (TF)

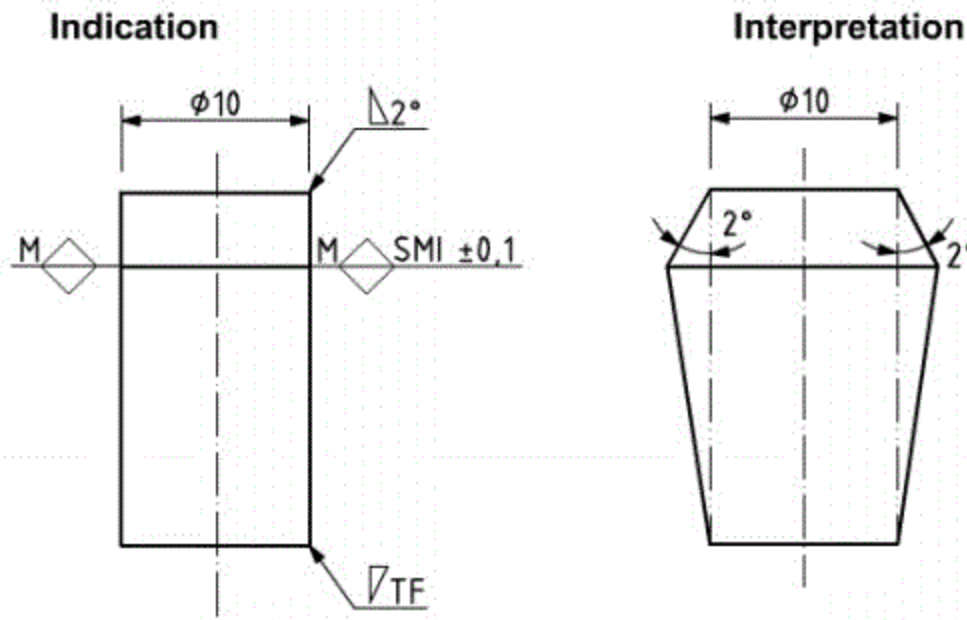


Figure 73 — Location dependant draft on a part with a specification of taper to fit (TF)

6.7.6 Extent of draft angle

For elements of revolution the following basic rules apply.

Rule 15 If the draft angle shall apply to a feature of revolution, the indication shall be shown on one side only (see Figure 74).

Rule 16 If the introduction of a parting surface to a feature of revolution intersects the complete rotational geometry, then an indication of a single draft angle only applies to that part of the feature to which the draft angle refers (see Figure 75).

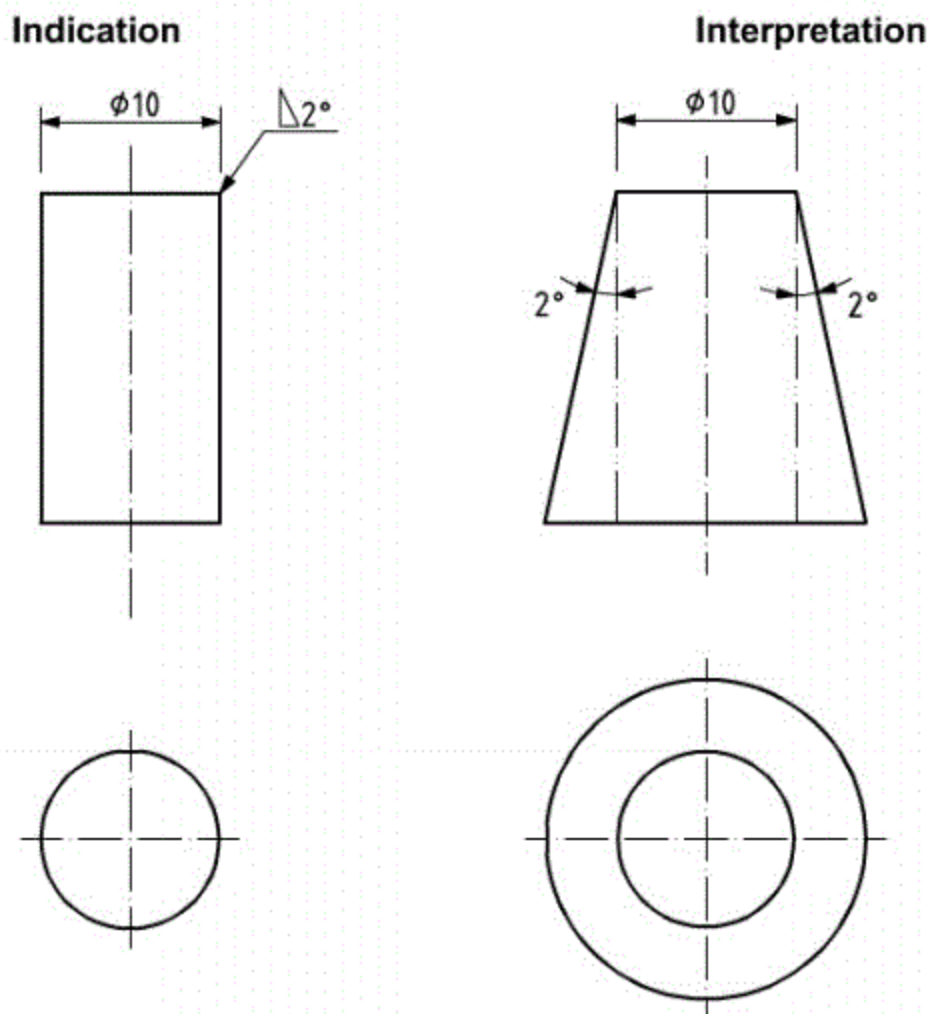


Figure 74 — Draft angle indication on a feature of revolution

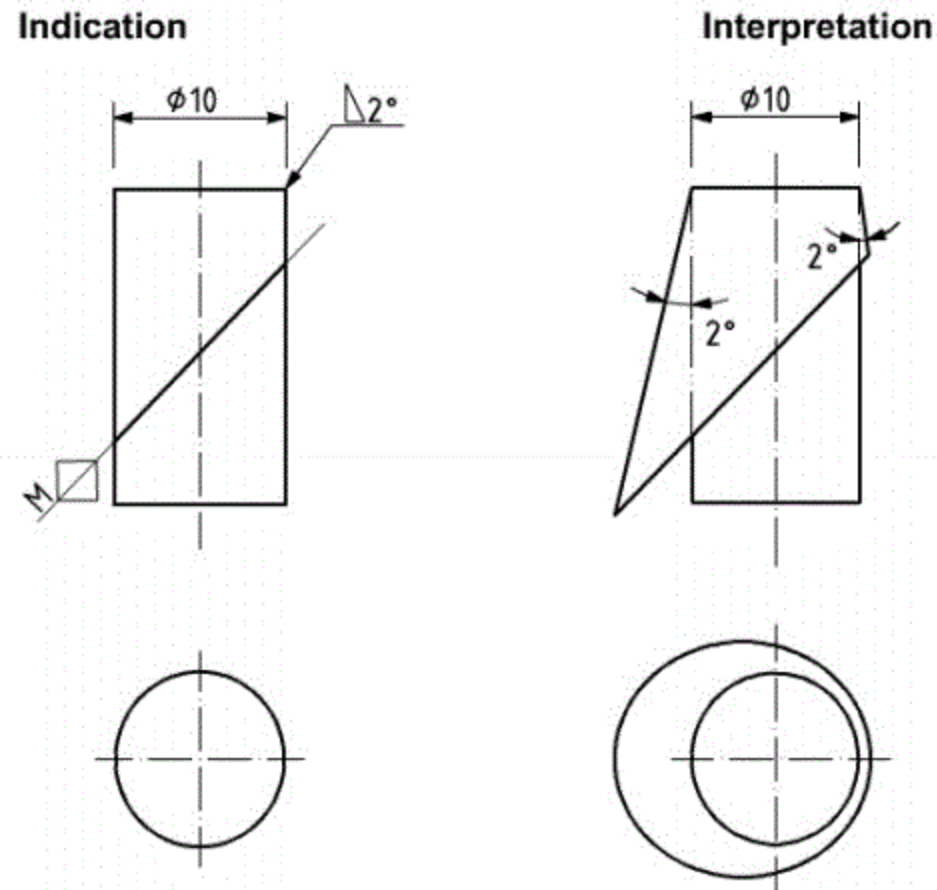


Figure 75 — Draft angle indication on a feature of revolution intersected by a parting surface

For elements of non-revolution the following basic rules apply:

- Rule 17** if the draft angle shall apply to a feature of non-revolution, the indication shall be shown for each feature (see Figure 76) or by extended indication of draft, see 6.6.3 and Figures 77 and 78.
- Rule 17.1** if the draft angle is indicated on a feature in a cross section of part, the draft angle applies to the full extent of that feature (see Figure 79).
- Rule 18** if the introduction of a parting surface intersects a feature, then an indication of a single draft angle only applies to that part of the feature to which the draft angle refers (see Figure 80).

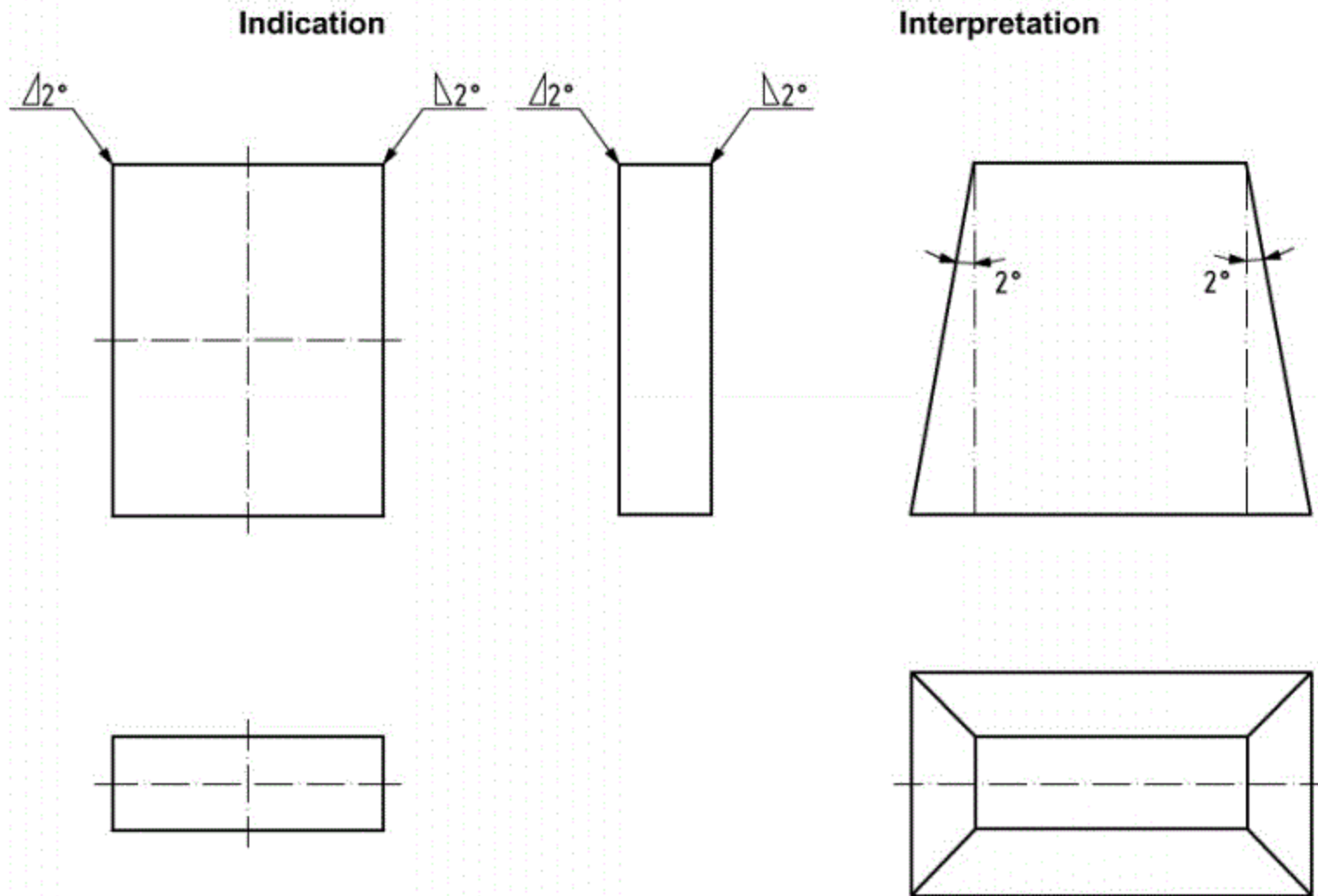
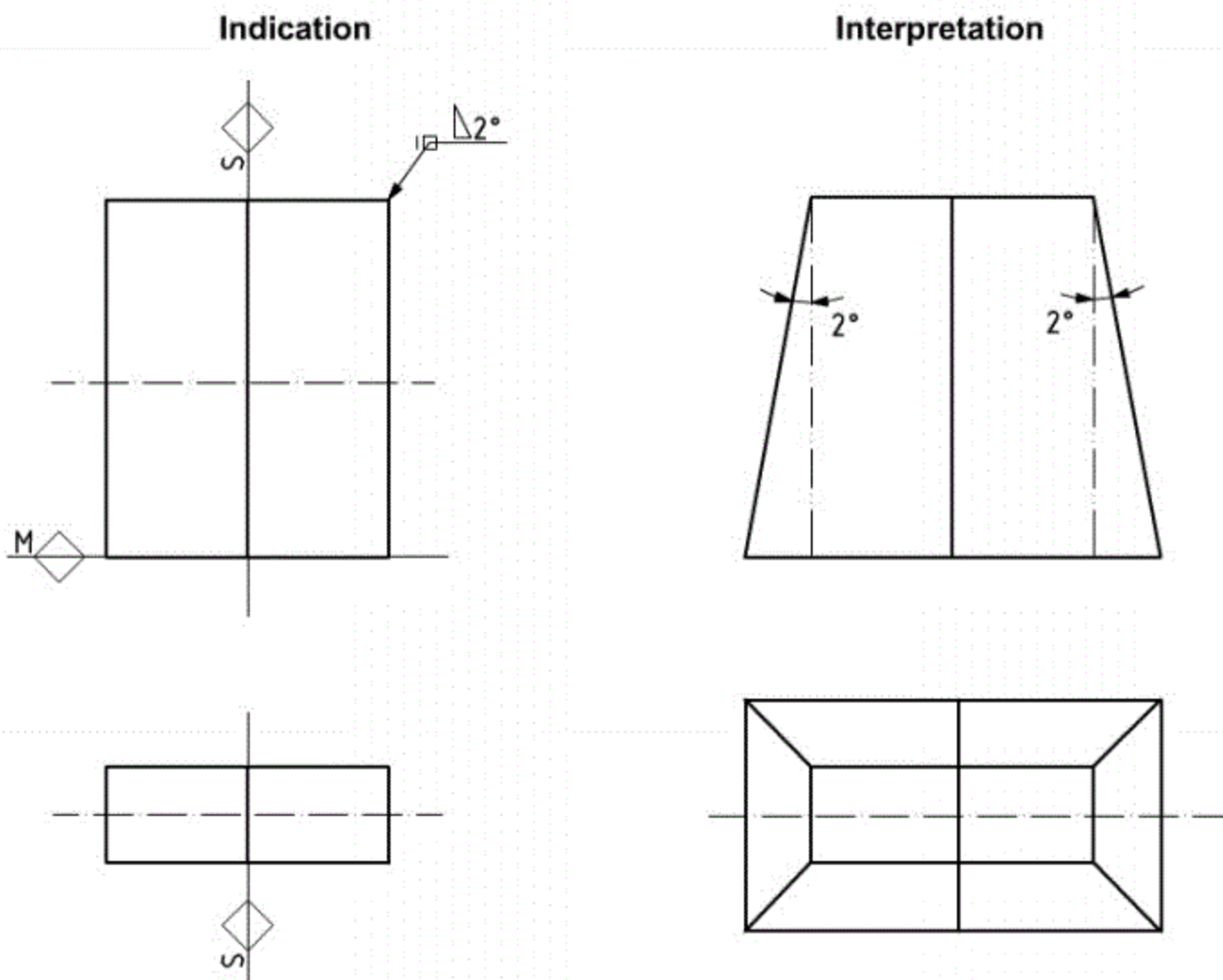


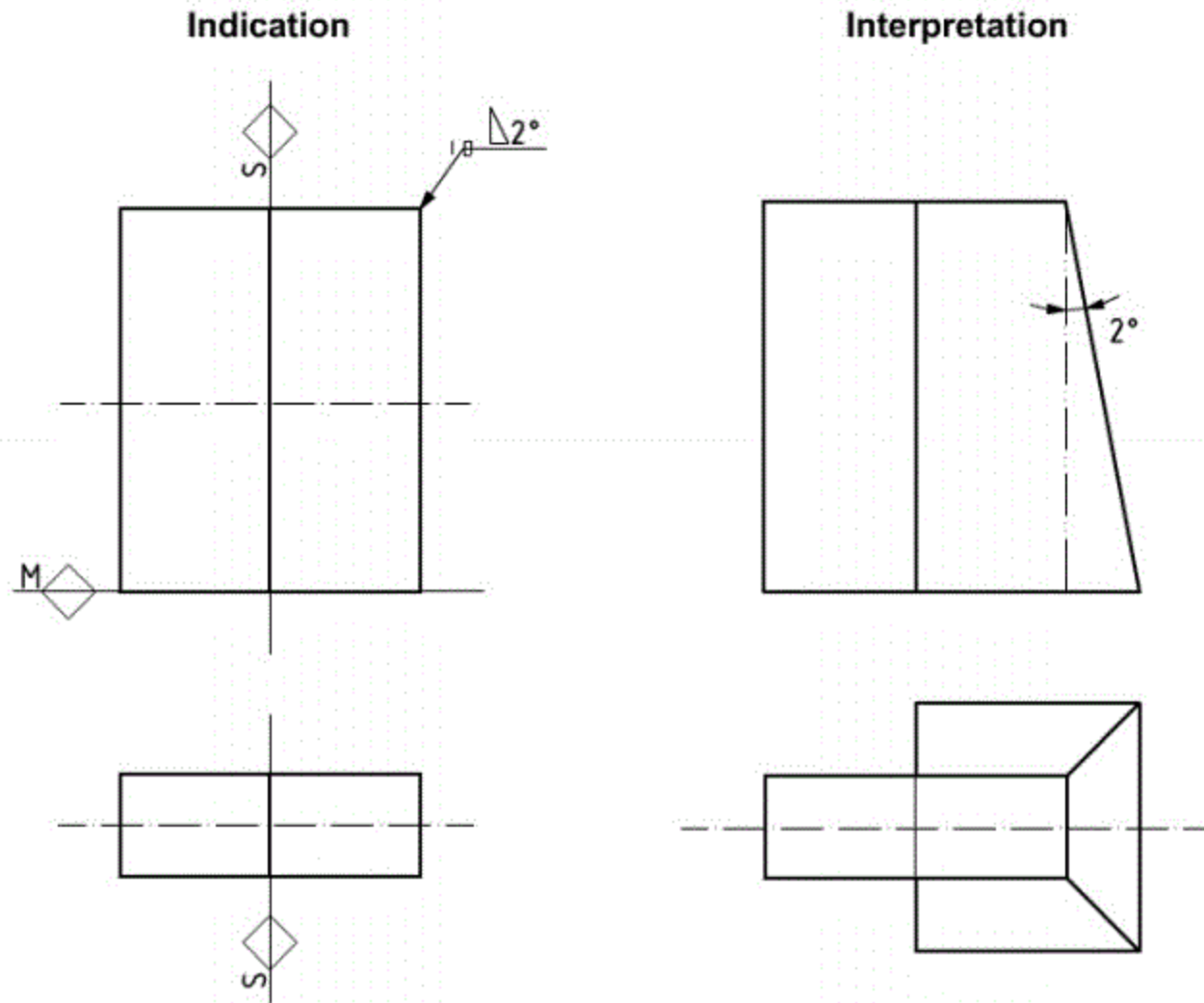
Figure 76 — Individual draft angle indication on four features



NOTE This simplified example does not reveal any practical application but is only intended to illustrate the interpretation rule of the drawing indication.

Figure 77 — Draft angle indication all about a part

No reproduction or retransmission permitted without ISO prior approval



NOTE This simplified example does not reveal any practical application but is only intended to illustrate the interpretation rule of the drawing indication.

Figure 78 — Draft angle indication partial all about a part intersected by a parting surface

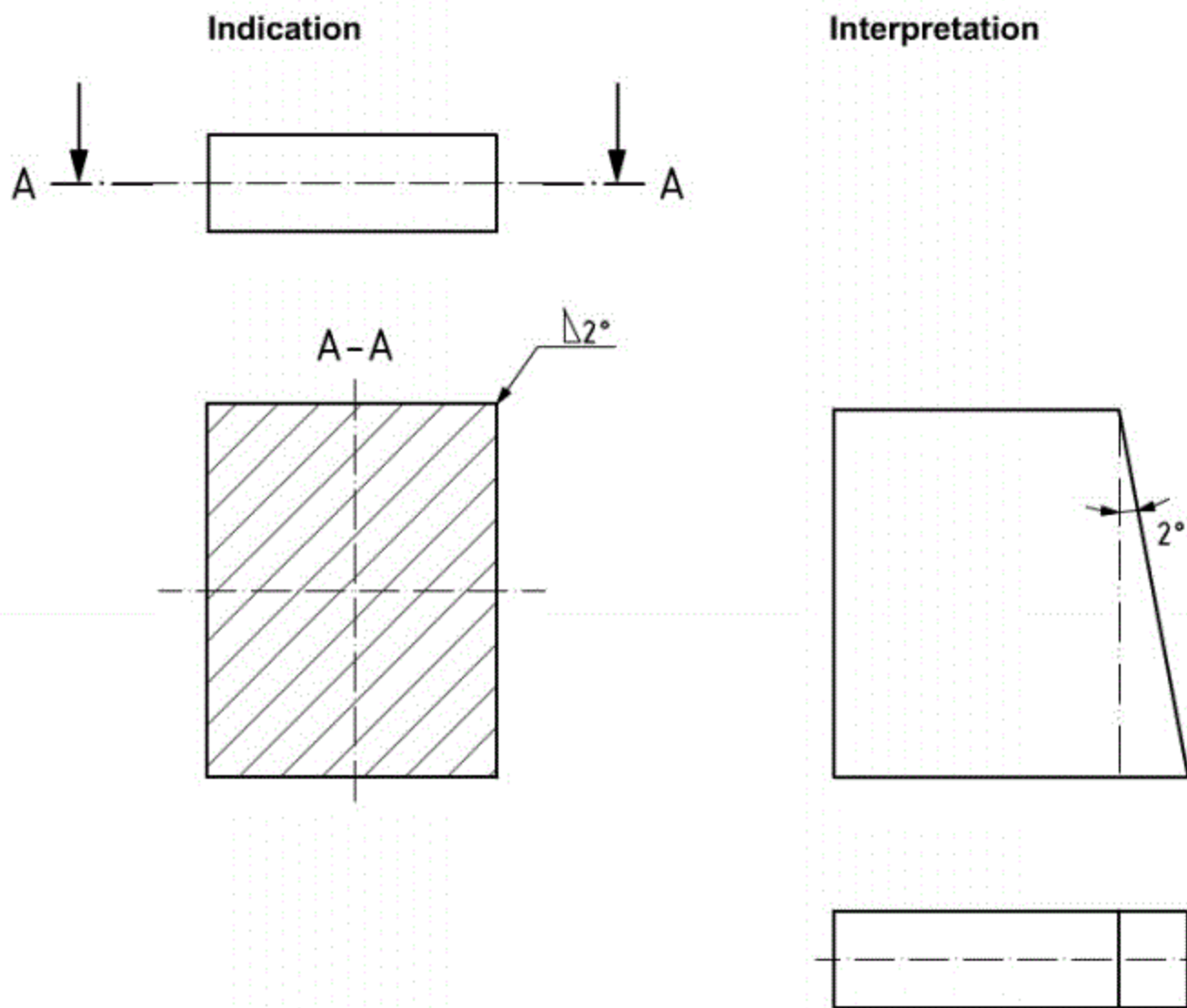


Figure 79 — Draft angle indication on a feature represented on a cross section of a part

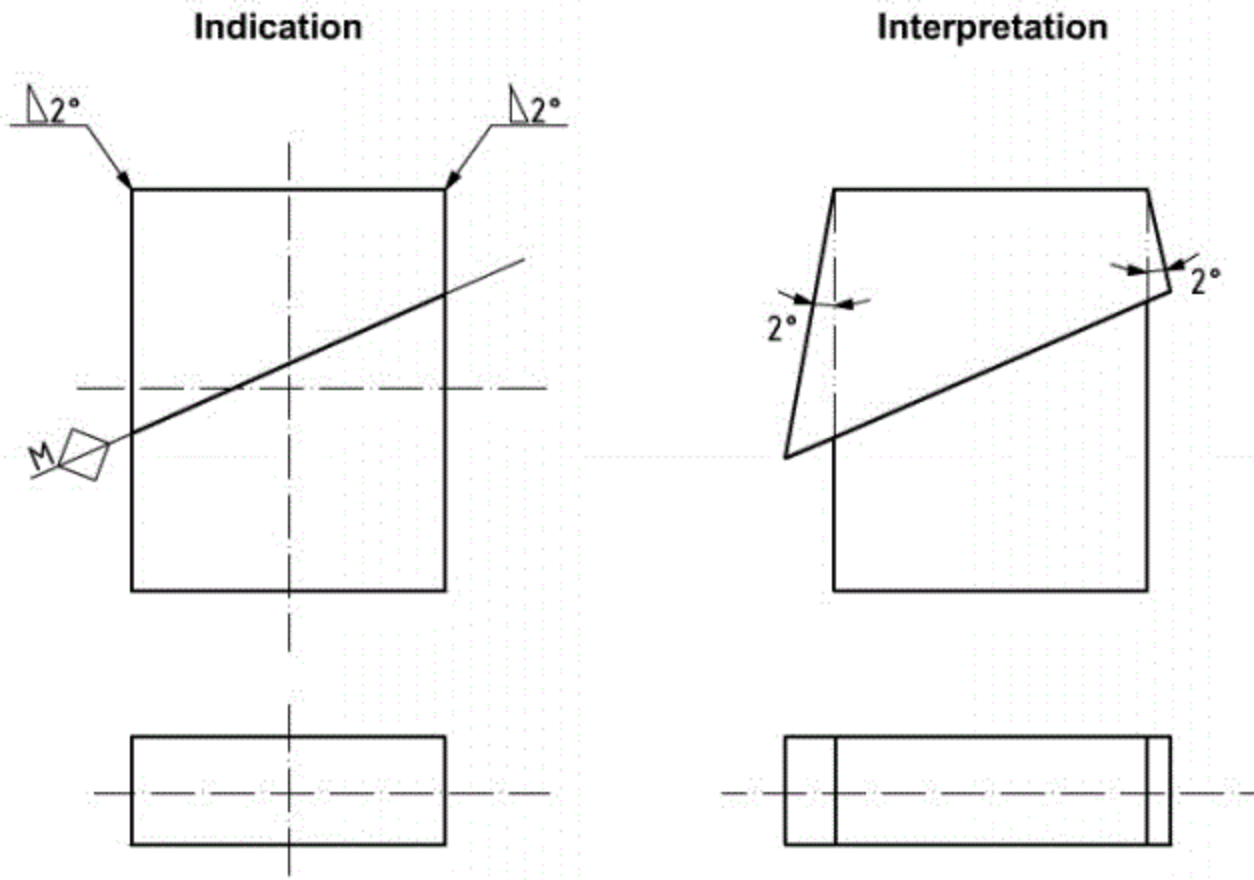


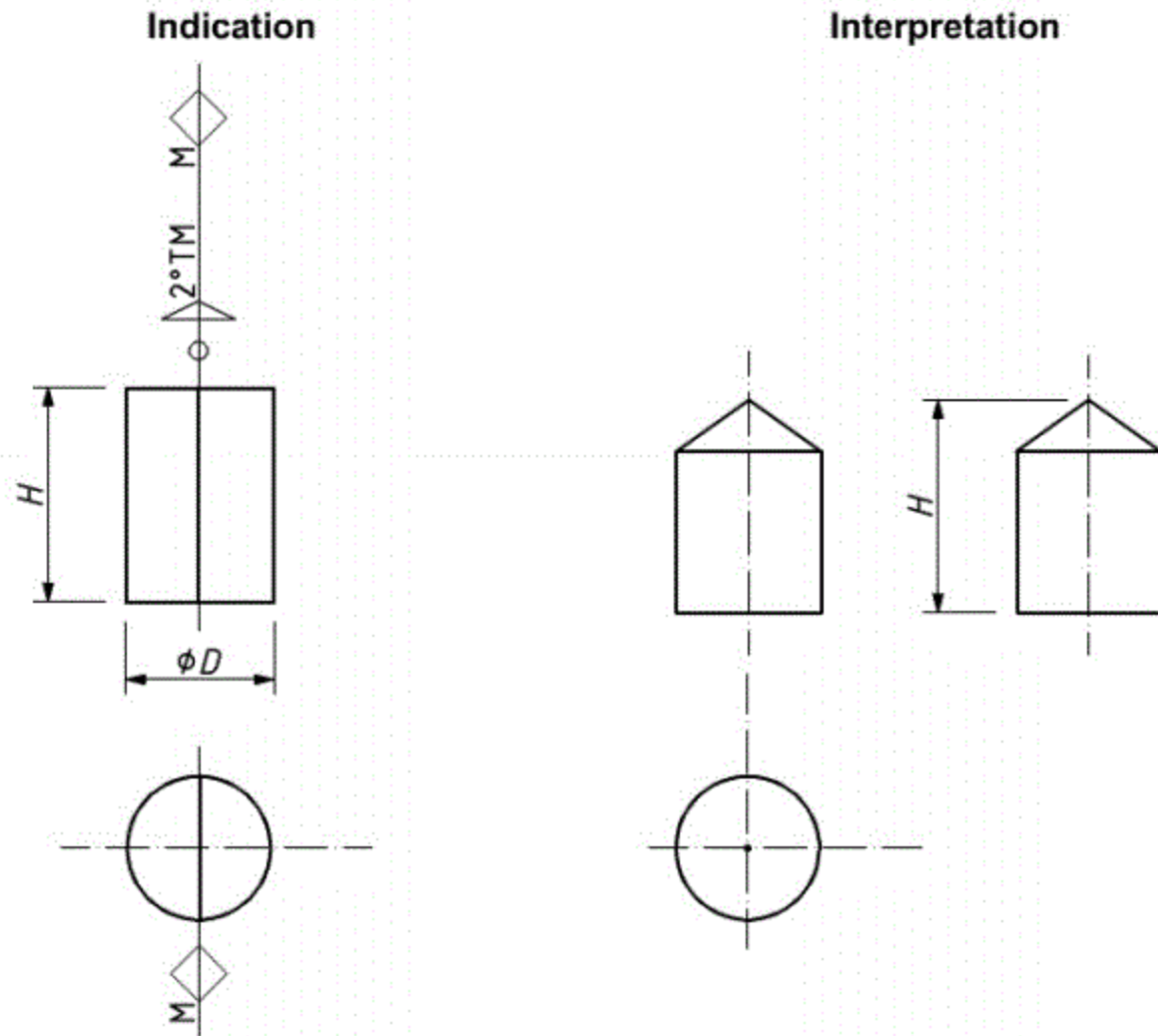
Figure 80 — Draft angle indication on two features, both intersected by a parting surface

6.7.7 Draft dependent on adjacent features

For indication of draft which shall rotate around a defined axis (e.g. associated derived feature of a cylinder or a symmetry axis), the following basic rule applies.

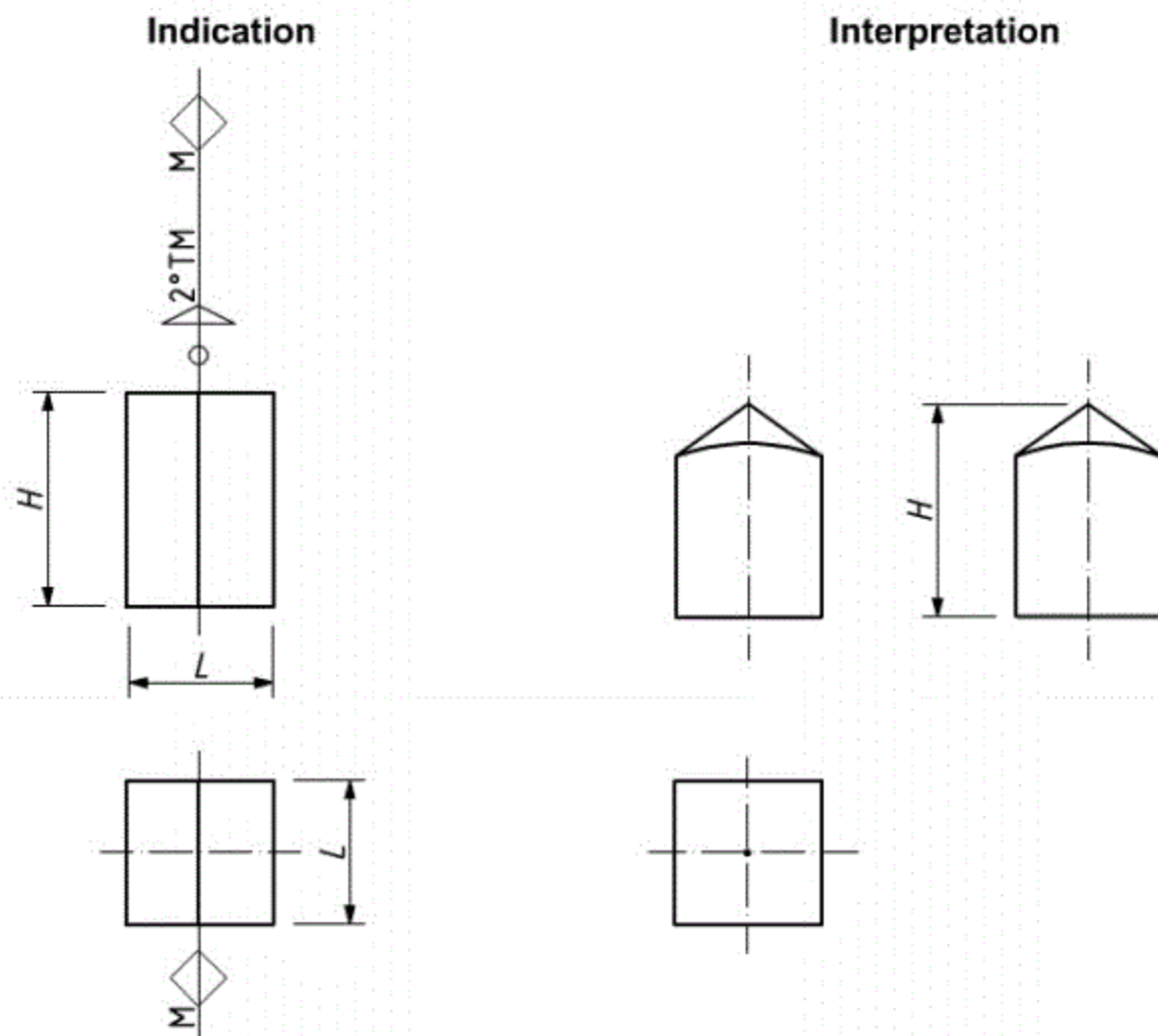
Rule 19 Nominally, the axis shall be included in the plane of the parting surface. The combined inclination symbol shall be applied in accordance with 6.7.3 and the global all around symbol shall be added to the parting line and positioned between the feature outline and the combined inclination symbol (see Figures 81 and 82).

NOTE The use of the all around symbol in this special case indicates rotation around an axis of a feature and results in a conical surface.



NOTE This simplified example does not reveal any practical application but is only intended to illustrate the interpretation rule of the drawing indication.

Figure 81 — Indication of draft depending on an axis of revolution



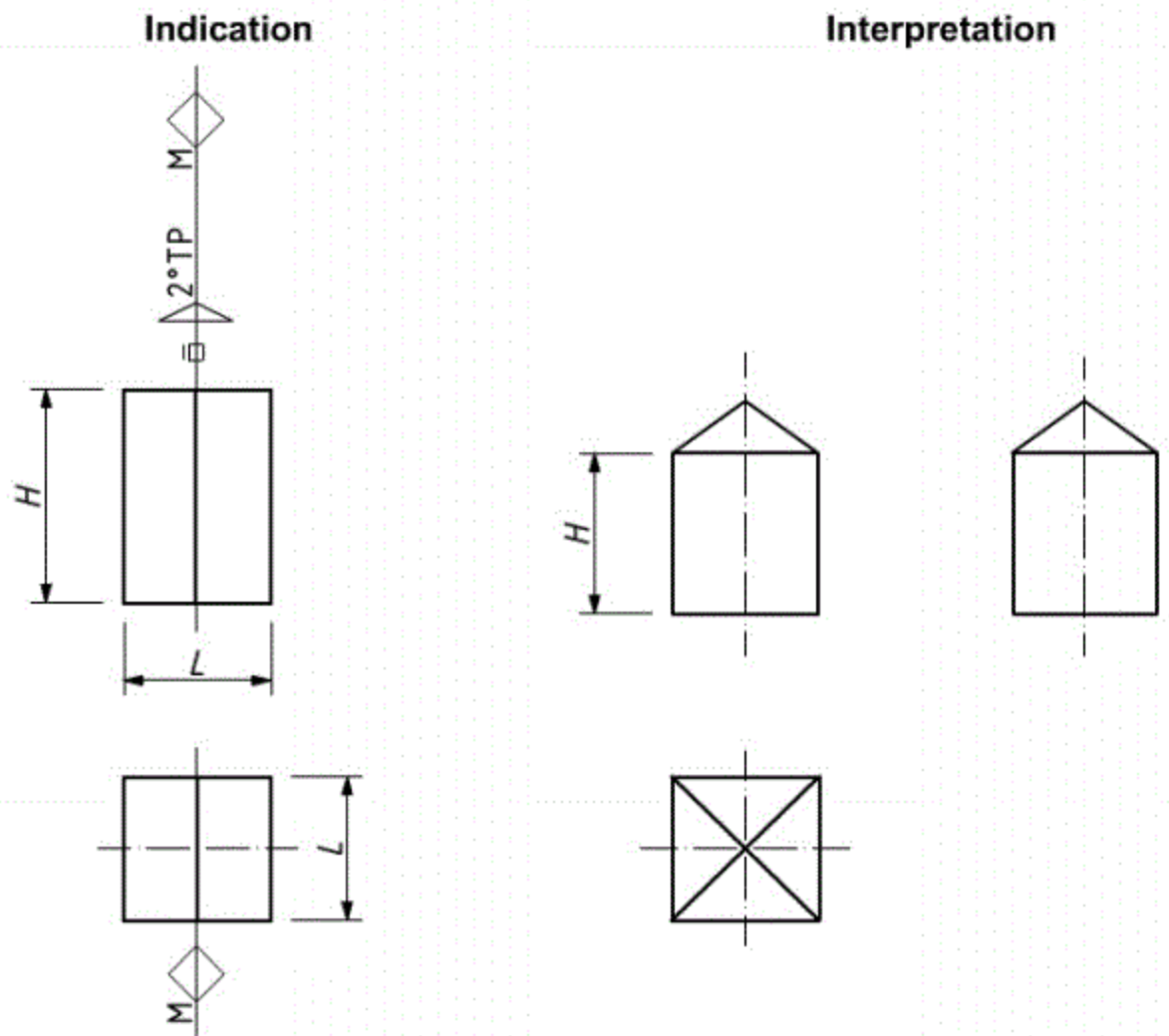
NOTE This simplified example does not reveal any practical application but is only intended to illustrate the interpretation rule of the drawing indication.

Figure 82 — Indication of draft depending on a symmetry axis

For an indication of draft, which depends on the orientation of all other features that are intersecting that feature and are establishing the limitation of the extent of the feature, the following basic rule applies.

Rule 20 The combined inclination symbol shall be applied in accordance with 6.7.3 and the global all about symbol shall be added to the parting line and positioned between the feature outline and the combined inclination symbol (see Figure 83).

NOTE The use of the all about symbol indicates that the draft follows the intersection of all the adjacent features in a plane perpendicular to the plane of the drawing and results in a pyramidal surface.



NOTE This simplified example does not reveal any practical application but is only intended to illustrate the interpretation rule of the drawing indication.

Figure 83 — Indication of draft depending on adjacent features

6.8 Tool motion direction

If it is necessary to specify the motion direction of shaping mould components, e.g. die halves, cores or sliders the graphical symbol shown in Figure 84 shall be used as illustrated in Figure 85. For details of the symbol, see Figure A.19.



Figure 84 — Graphical symbol for tool motion direction

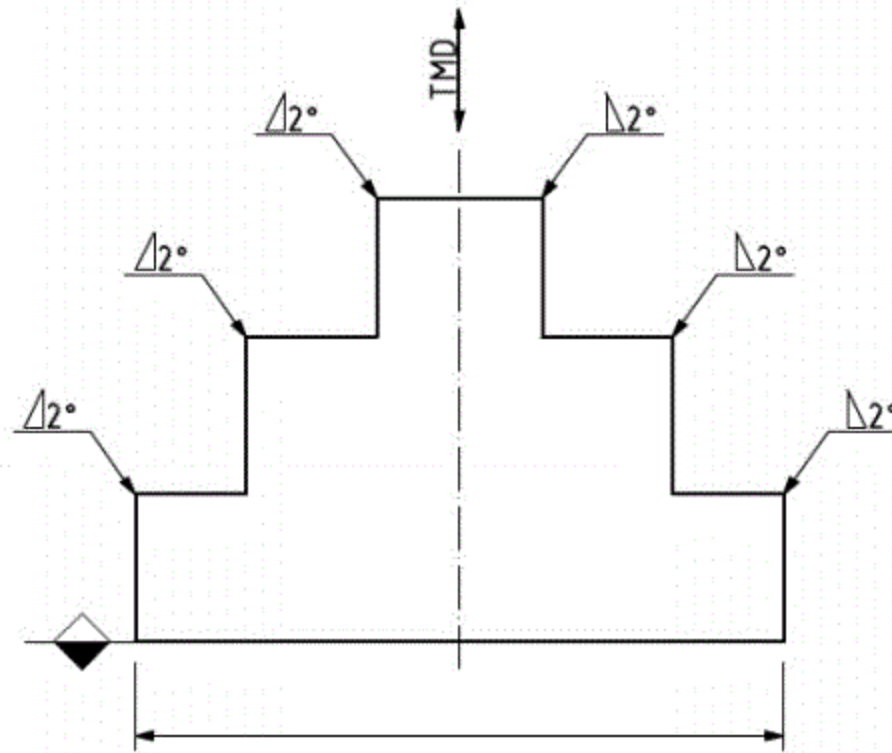
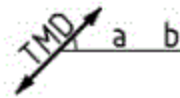


Figure 85 — Example of the indication of tool motion direction

If it is necessary to specify the type of the movable tool part or the angle of the tool motion direction it shall be indicated above a reference line, which is connected to the graphical symbol as, shown in Figure 86.



Key

- a Position of type of the movable tool part.
- b Position of angle specification.

Figure 86 — Position of the possible indication on the graphical symbol for tool motion direction

The type of the tool part may be indicated using a letter symbol according to Table 7 as shown in Figure 87.

Table 7 — Letter symbol for types of the movable tool

Letter symbol	Application
C	Movable cores
M	Movable main part
S	Movable sliders

The angle may be specified with a tolerance as shown in Figure 87.

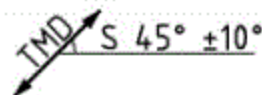


Figure 87 — Example of a specification of tool motion direction

Carefully design of the tool motion direction in the mould can make draft superfluous, see Figure 88.

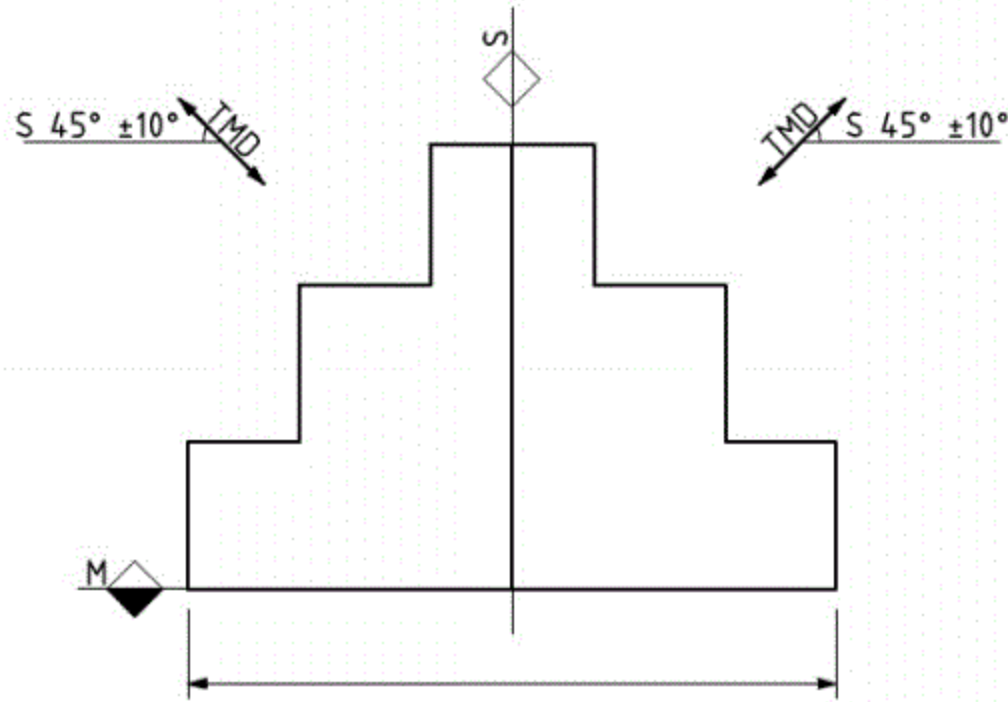


Figure 88 — Example of tool motion direction that makes draft superfluous

6.9 Part removal direction

If it is necessary to specify the removal direction of the moulded part, the graphical symbol shown in Figure 89 shall be used as illustrated in Figure 90. For details of the symbol, see Figure A.20.



Figure 89 — Graphical symbol for part removal direction a) or b)

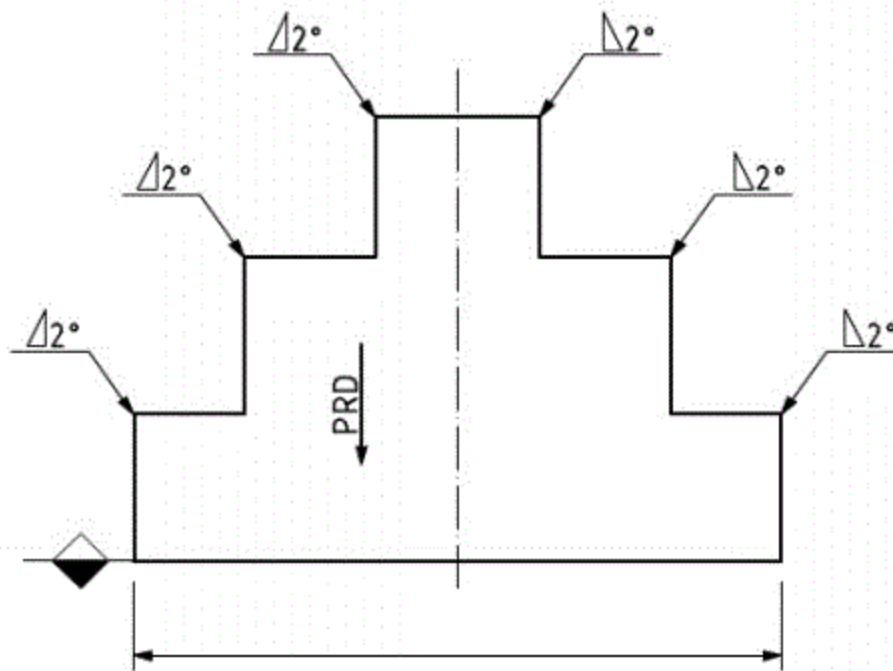
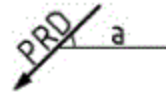


Figure 90 — Example of specification of permissible angle on part removal direction

If it is necessary to specify the angle of the part removal direction it shall be indicated above a reference line, which is connected to the graphical symbol as shown in Figure 91 and Figure 92.



Key

a Position of angle specification.

Figure 91 — Position of the angle indication on the graphical symbol for part removal direction

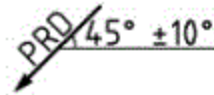


Figure 92 — Example of a specification of part removal direction

6.10 Surface enlargement

To make the moulding process feasible it may be necessary to optimize the design of the part, e.g. to improve heat transfer or for adhesion of release agents in deep parts of the die cavity, by enlarging particular surfaces on the part by ribs or raster.

NOTE To improve heat transfer and increase the durability of a permanent mould, small ribs may be required especially at fillet.

When the design and geometry of the ribs or raster is left to the manufacturer of the mould, the surface enlargement symbol shown in Figure 93 shall be used. For details of the symbol, see Figure A.17.



Figure 93 — Graphical symbol for surface enlargement

The symbol shall be placed at the remote end of a leader line, see Figure 94.



Figure 94 — Indication of surface enlargement

The surfaces enlargement sign applies only on the feature or the area at which the terminator of the leader line is pointing, see Figures 95 and 96.

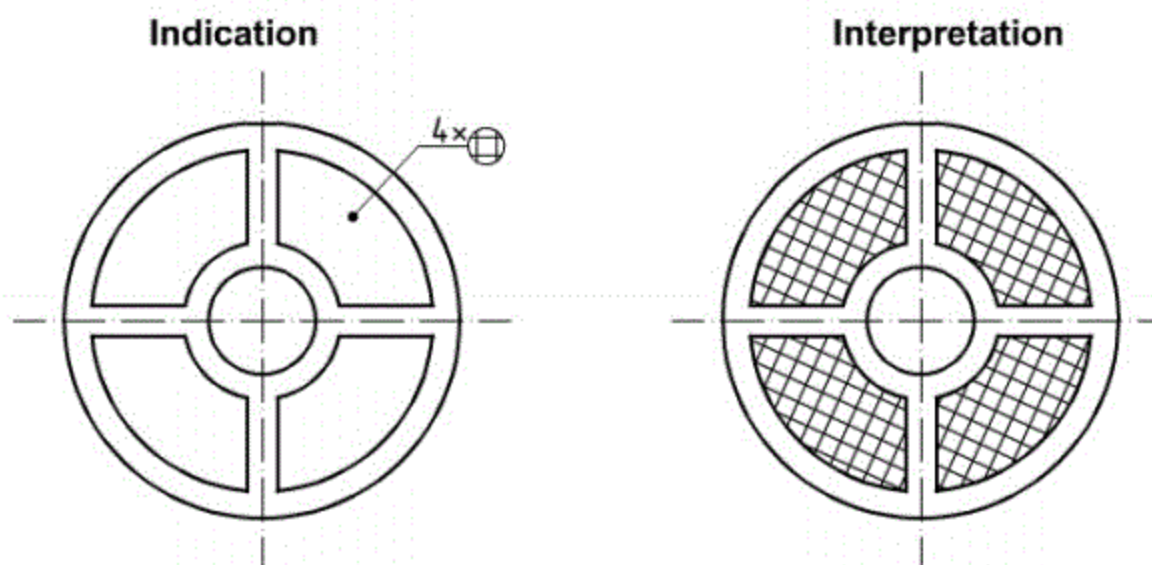


Figure 95 — Example of surface enlargement indication

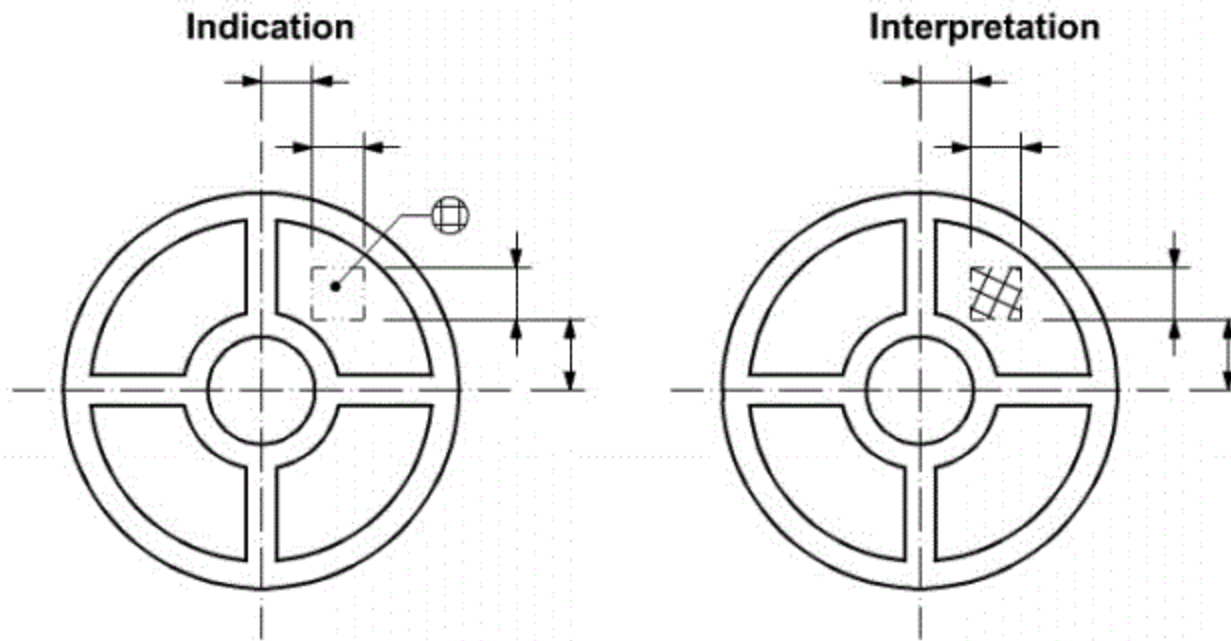


Figure 96 — Example of surface enlargement

6.11 Sinks

When it is necessary to specify the maximum permissible dimensions of sink marks on a workpiece surface e.g. caused by contraction of material during cooling, it shall be indicated by the graphical symbol shown in Figure 97. This shall be placed above the reference line (see ISO 128-22), which is drawn parallel to the surface indicated by the arrowhead, and followed by the corresponding numerical values (see Figure 98).



Figure 97 — Graphical symbol for sinks

Key

a Position of dimension.



Figure 98 — Graphical symbol for sinks used with leader and reference lines

The permissible local deviation of the feature from the surface may be indicated by adding values after the graphical symbol indicating the sink. The value representing the maximum permissible depression on the surface (SIM_{sd} in accordance with ISO 8785) shall always be stated (see Figure 99). For details of the symbol, see Figure A.16.



Figure 99 — Sink marking symbol

If it is necessary to specify the maximum permissible area (SIM_w and $SIME$ in accordance with ISO 8785), it shall be indicated in brackets after the value of the maximum permissible depression, i.e.:

- as a diameter [see Figure 100 a)] by one value, or
- by two values representing the area or a rectangle [see Figure 100 b)] where the first value represents the direction in the plane of the drawing and the second value represents the direction orthogonal to the plane of the drawing.

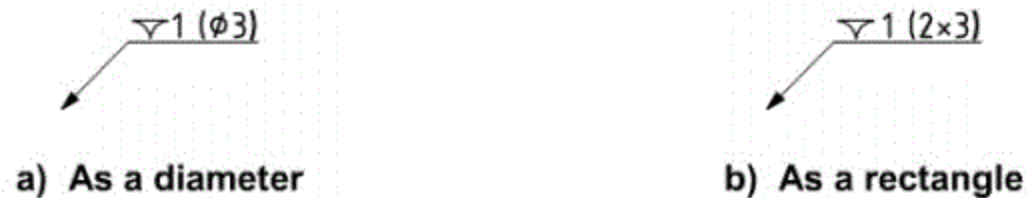


Figure 100 — Example of sink marking symbol used with maximum permissible dimension of sink mark

The interpretation of the sink mark specification given in Figure 100 a) is shown in Figure 101.

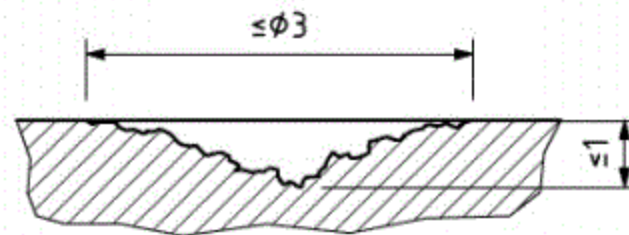


Figure 101 — Example on the interpretation of maximum permissible dimension of sink mark

6.12 Porosity

When it is necessary to specify the grade or the acceptable type, extent and/or magnitude of porosity on or in a moulded part it shall be indicated after the graphical symbol for porosity shown in Figure 102. For details of the symbol, see Figure A.18.

P

Figure 102 — Graphical symbol for porosity

The graphical symbol shall be placed on the reference line (see ISO 128-22) followed by the specification which is placed above the reference line, see Figure 103. For details of the symbol, see Figure A.18.



Key

- a Position of specification of porosity.

Figure 103 — Indication of porosity symbol used with leader and reference lines

If a specification implicitly refers to a specific document, e.g. a grade according to a company standard or a national standard, the document shall be referenced by stating the following information in or near the drawing title block:

“Porosity according to [document ID]”

6.13 Identification and marking

6.13.1 Moulded parts

If it is necessary to identify the moulded part, the following information may be given if feasible:

- cavity number;
- identification number (subject number or part number);

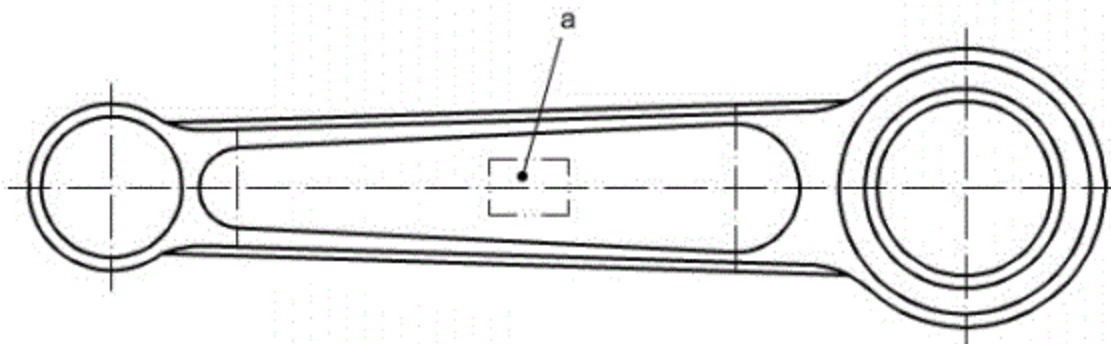
- c) recycling mark;
- d) manufacturer's identification mark.

The manufacturing date and a material number or a melt/charge number may also be given.

6.13.2 Position of identification and markings

The position of the identification and markings shall be specified or indicated on the drawing. It shall not be positioned at surfaces which are to be machined. (It must be possible to separate the part from the mould.)

The position shall be framed using a long dashed double-dotted narrow line (see Table 2). See Figure 104.



- a Position of identification.

Figure 104 — Position of identification and marking

6.13.3 Lettering

The lettering shall be specified in terms of the following information:

- a) elevated or depressed;
- b) lettering height;
- c) kind of lettering.

6.14 Other necessary information

In order to complete the technical documentation, further information may be necessary, concerning, e.g.:

- heat treatment;
- density;
- structures of the material, such as run of the fibre, grain flow, components of multi component materials; these may be indicated, if necessary, in an additional document representing the section and the structure by continuous thin freehand lines;
- degree of accuracy;
- casting error.

This information can be obtained from standards or documents other than technical drawings.

6.15 Special indication for undisturbed surfaces

Where a design requires that a feature – under no circumstances – may be disturbed by any tool-dependent discontinuities or surface imperfections, e.g. parting lines, tool markings or identification marks, it shall be indicated by the graphical symbol shown in Figure 105. For details of the symbol, see Figure A.16.



Figure 105 — Graphical symbol for undisturbed surfaces

The symbol shall be placed at the remote end of a leader line, see Figure 106.

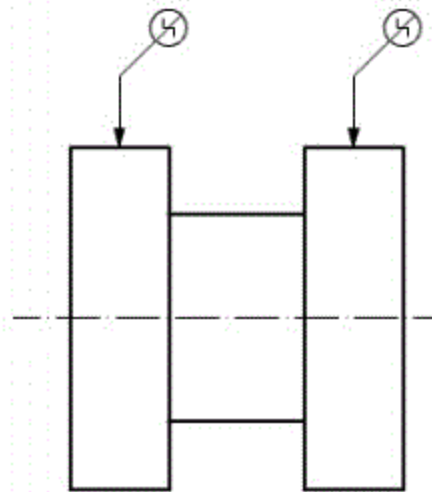


Figure 106 — Indication of undisturbed surface

The undisturbed surfaces sign applies only on the feature or the area at which the terminator of the leader line is pointing.

7 Rules for linear and geometrical dimensioning and tolerancing

7.1 Linear dimensioning and tolerancing

7.1.1 General

Linear dimensioning shall be executed in accordance with ISO 129-1 and linear tolerances shall be executed in accordance with ISO 406.

Draft angles are to be regarded as a nominal correction value for a stated nominal linear dimension and apply for the moulded part only.

7.1.2 Features of size

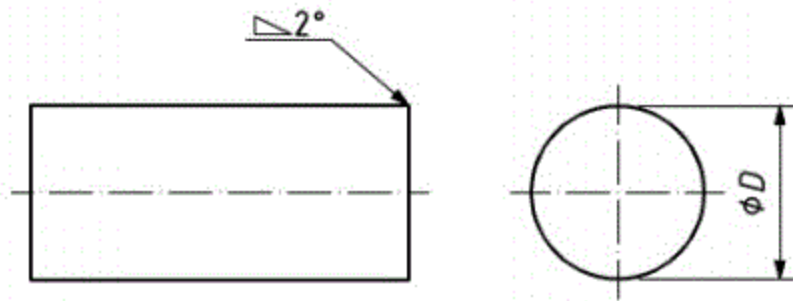
7.1.2.1 General

The default linear dimension and tolerance of a feature of size with draft on a moulded part is defined as two-point sizes in cross-sections perpendicular to the axis of the associated cone obtained from the extracted surface (see also ISO 14660-2).

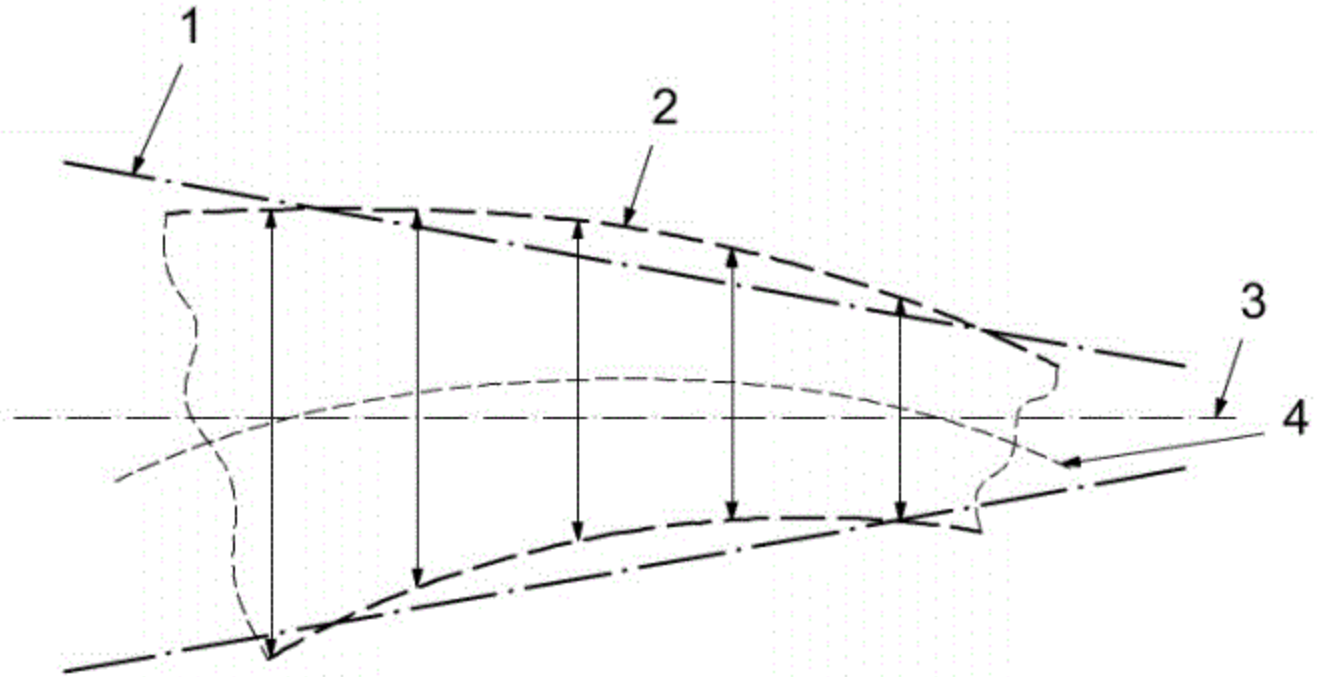
The size definition can be altered by using the modifiers given in ISO 14405.

Unless specifically indicated (e.g. by MMR or LMR, according to ISO 2692), the linear dimension and tolerance of a feature of size with draft on a moulded part, neither control the form of the axis nor the symmetry plane of the feature of size (see Figure 107).

Indication



Interpretation



Key

- 1 associated cone
- 2 extracted surface
- 3 associated axis
- 4 extracted median line

Figure 107 — Local linear dimensions of a feature of size (cylinder) with draft controlled in cross-sections perpendicular to the axis of the associated cone (cone angle equal to two times draft angle)

Surface mismatch is included in the dimension of a feature of size, which is parted by a parting surface, see Figures 108 and 109.

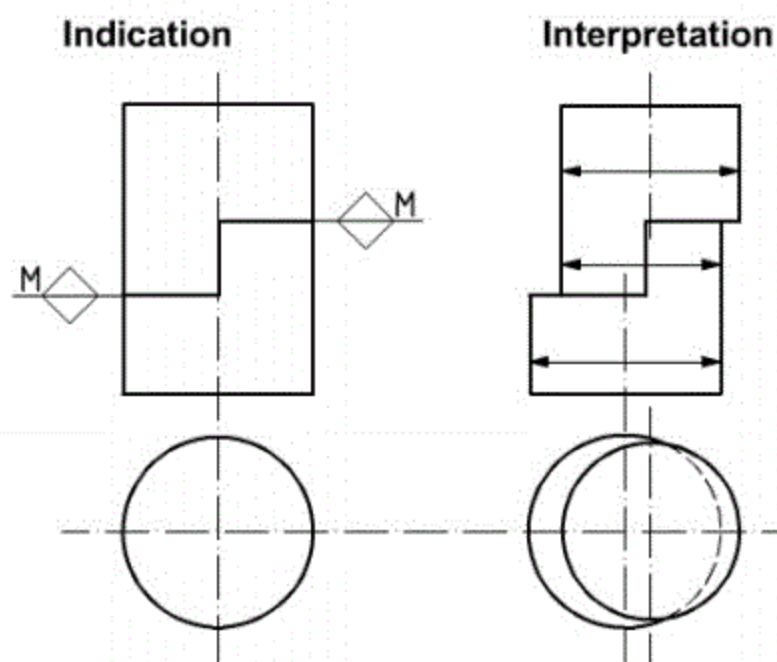


Figure 108 — Example of local dimensions on a feature of size

No representation of manufacturing conditions without consent. Draw 2007

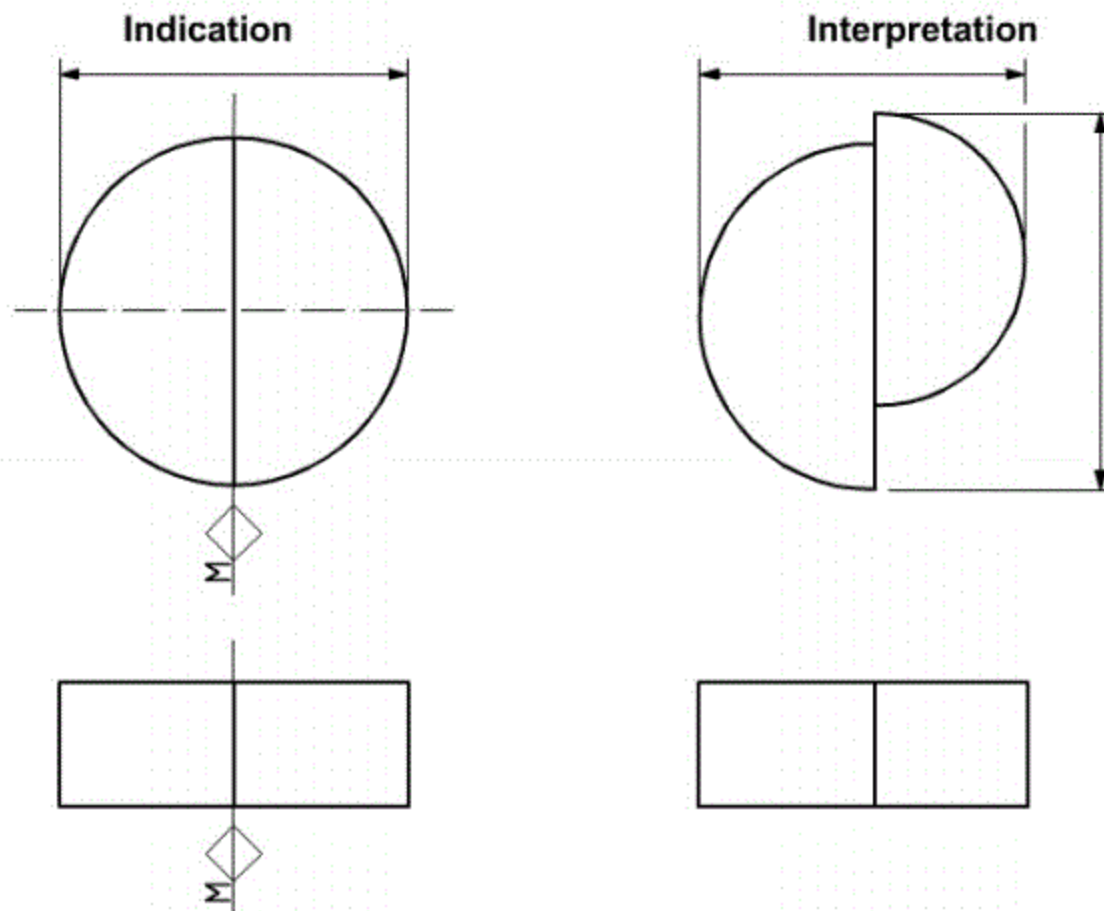


Figure 109 — Example of local dimensions of a feature of size

7.1.2.2 Dimensions

The dimension of a feature of size on a moulded part shall be corrected for the effect of draft angles depending on whether material shall be added (TP) or subtracted (TM) (indicated by the orientation of the inclination symbol) according to Tables 8 and 9.

Table 8 — Correction for the effect of draft angles when material shall be added

Feature	External feature of size	Internal feature of size
Revolution	Dimension + $2 \times \tan(W) \times X$ See Figure 109	Dimension - $2 \times \tan(W) \times X$ See Figure 111
Non-revolution	Dimension + $\tan(W1) \times X + \tan(W2) \times X$	Dimension - $\tan(W1) \times X - \tan(W2) \times X$

Table 9 — Correction for the effect of draft angles when material shall be removed

Feature	External feature of size	Internal feature of size
Revolution	Dimension - $2 \times \tan(W) \times X$	Dimension + $2 \times \tan(W) \times X$
Non-revolution	Dimension - $\tan(W1) \times X - \tan(W2) \times X$ see Figure 110	Dimension + $\tan(W1) \times X + \tan(W2) \times X$ see Figure 112

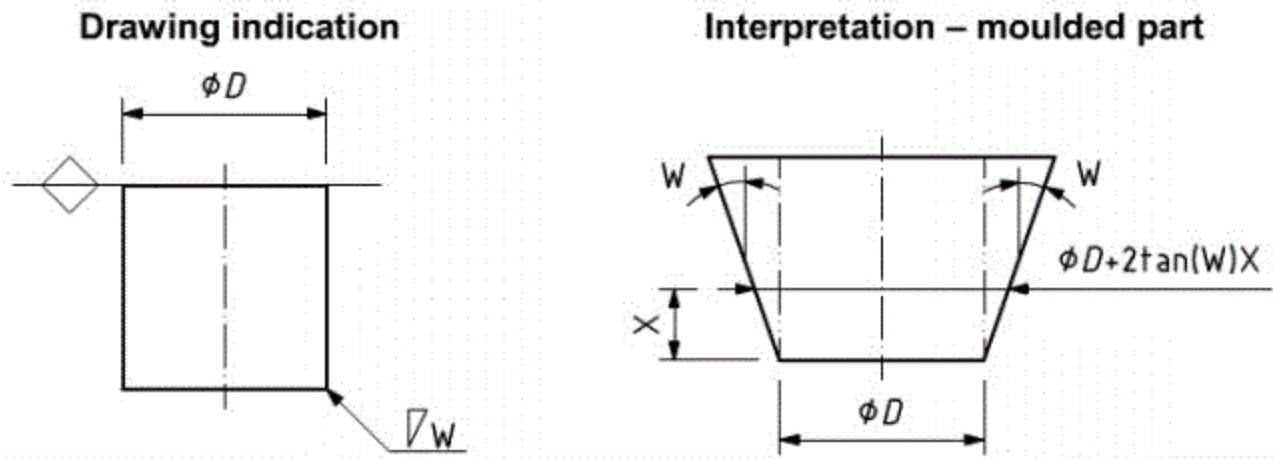


Figure 110 — Local diameter of an external feature of size on a feature of revolution

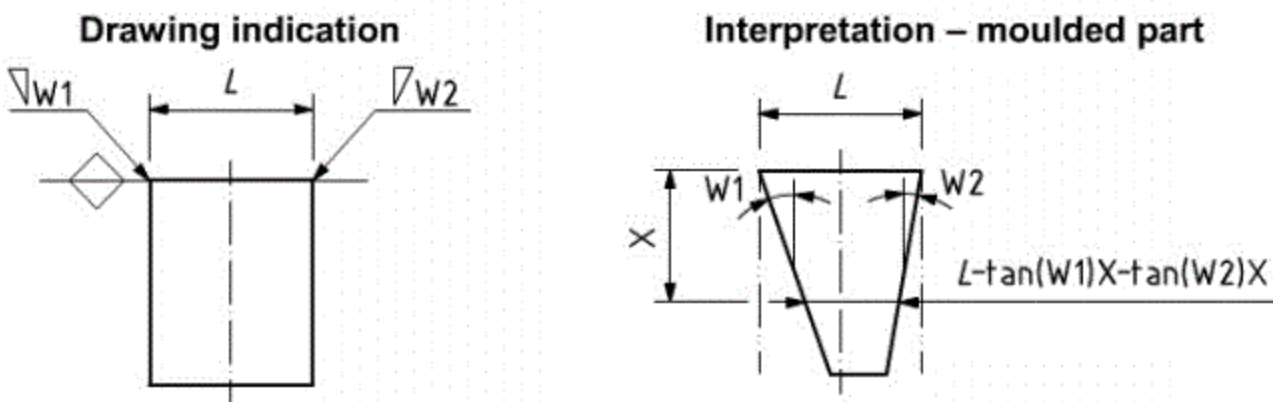


Figure 111 — Local size of an external feature of size on a feature of non-revolution

7.1.3 Non-features of size

In order to control the dimension of non-features of size, it is recommended to use geometrical tolerancing in accordance with ISO 1101, since the use of linear dimensioning and tolerancing for non-features of size is ambiguous.

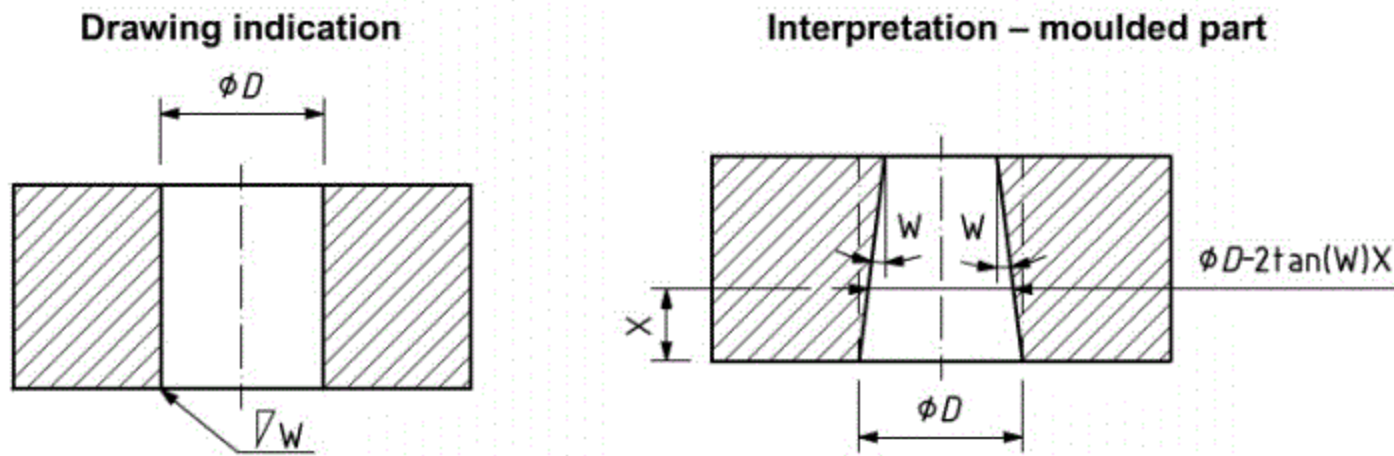


Figure 112 — Diameter of an internal feature of size on a feature of revolution

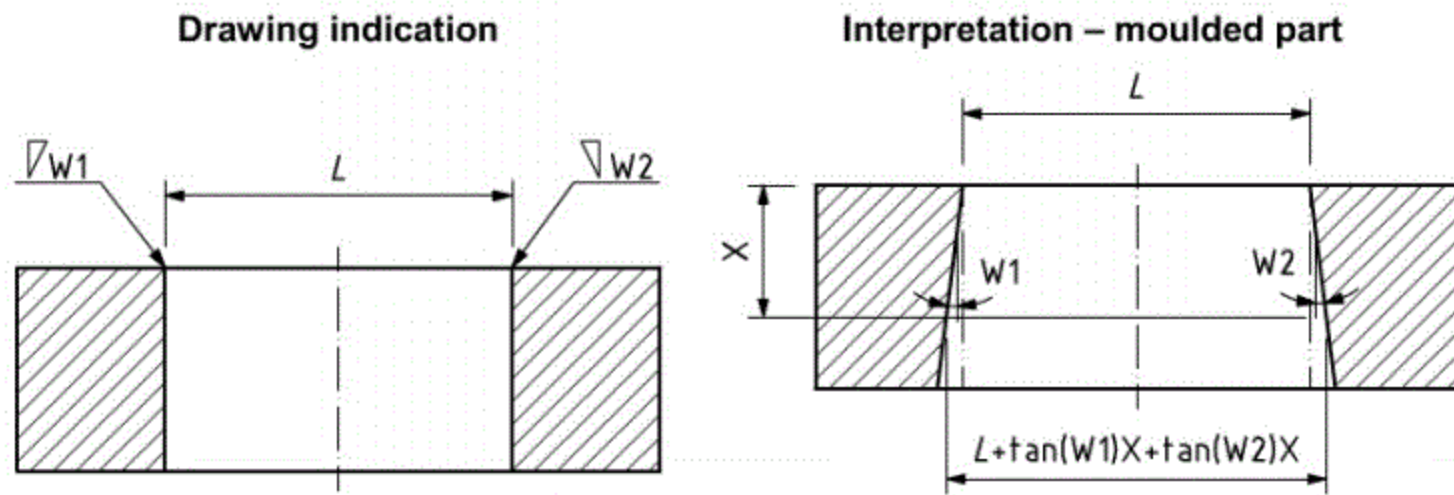


Figure 113 — Local size of an internal feature of size on a feature of non-revolution

7.2 Geometrical tolerancing

Individual geometrical tolerances shall be indicated in accordance with ISO 1101.

7.3 Datums

Datums and datum-systems shall be indicated in accordance with ISO 5459.

7.4 Surface texture

Surface texture shall be indicated in accordance with ISO 1302.

7.5 Edges

States of edges shall be indicated in accordance with ISO 13715.

Annex A (normative)

Proportions and dimensions of graphical symbols

A.1 General requirement

In order to harmonize the size of the symbols specified in this International Standard with those of other inscriptions on technical drawings (dimensions, geometrical tolerances, etc.) the rules given in ISO 81714-1 shall be applied.

A.2 Application

The graphical symbols given in ISO 1302, ISO 7083 and ISO 13715 shall be used.

A.3 Proportions

The graphical symbols and the additional indications in the area "a" shall be draughted in accordance with Figures A.1 to A.20.

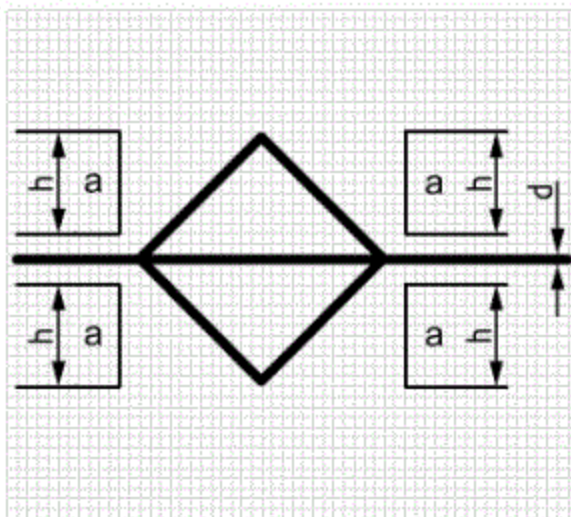


Figure A.1

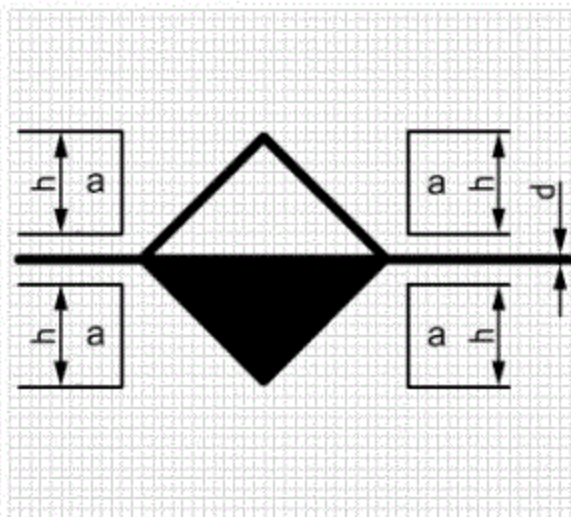


Figure A.2

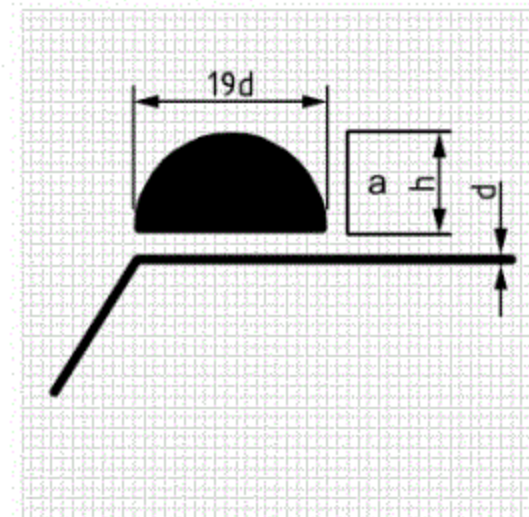


Figure A.3

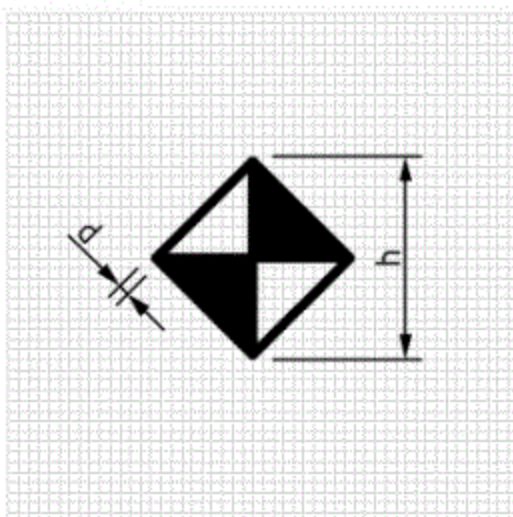


Figure A.4

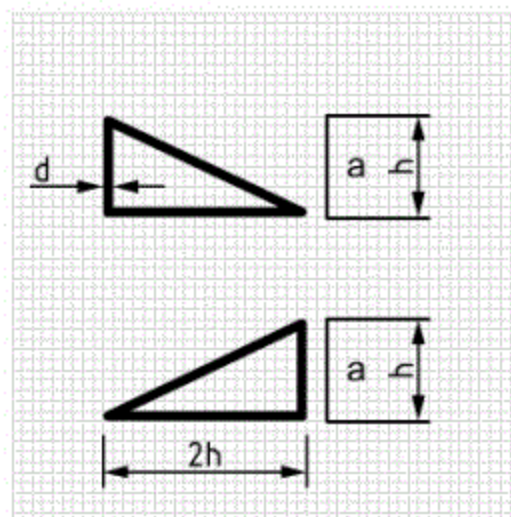


Figure A.5

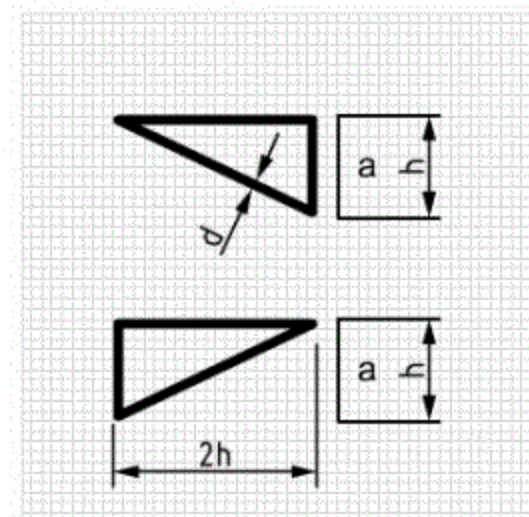


Figure A.6

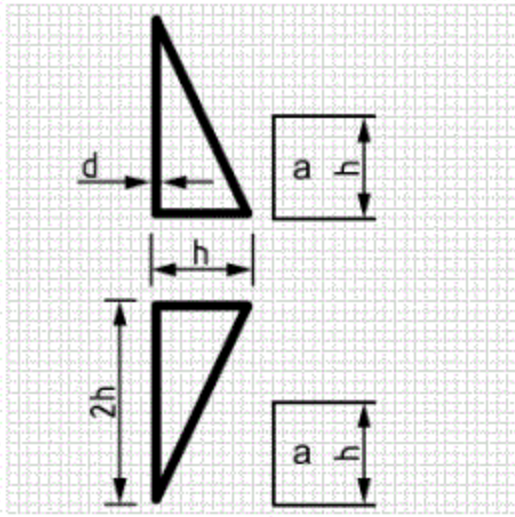


Figure A.7

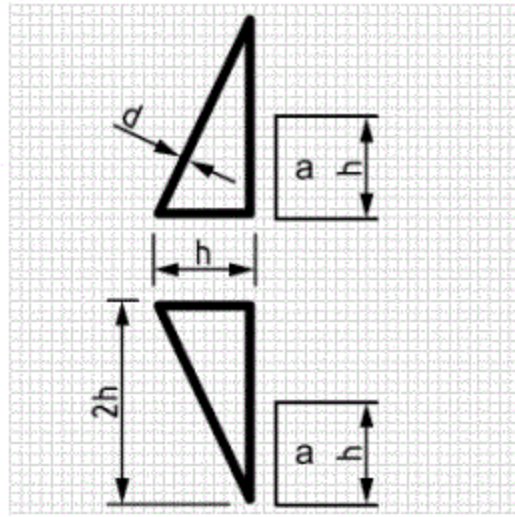


Figure A.8

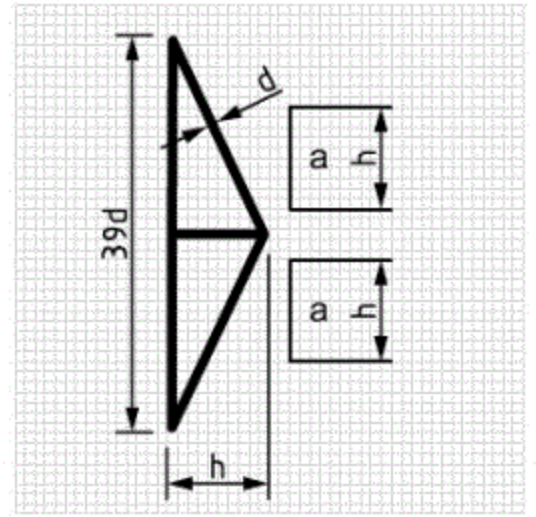


Figure A.9

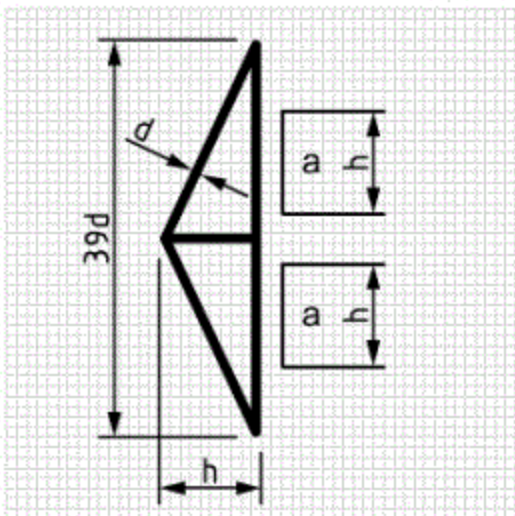


Figure A.10

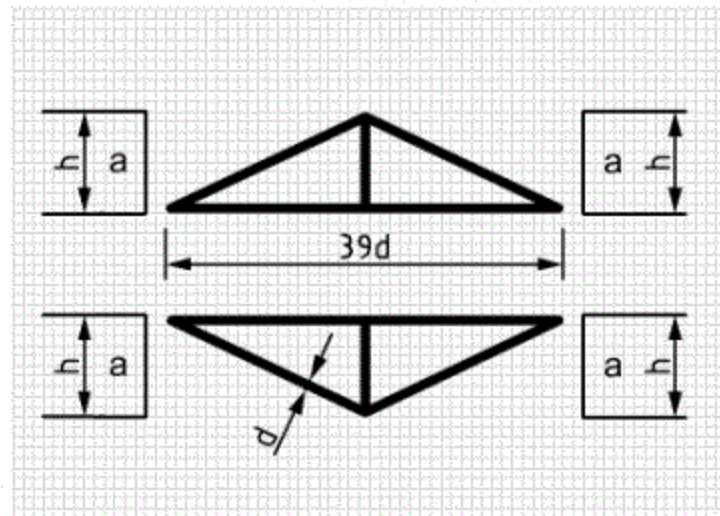


Figure A.11

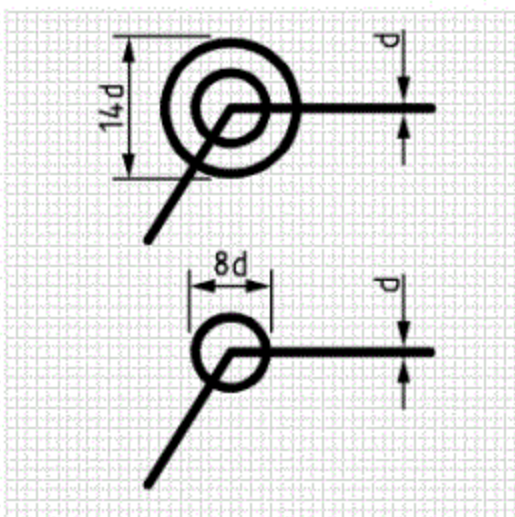


Figure A.12

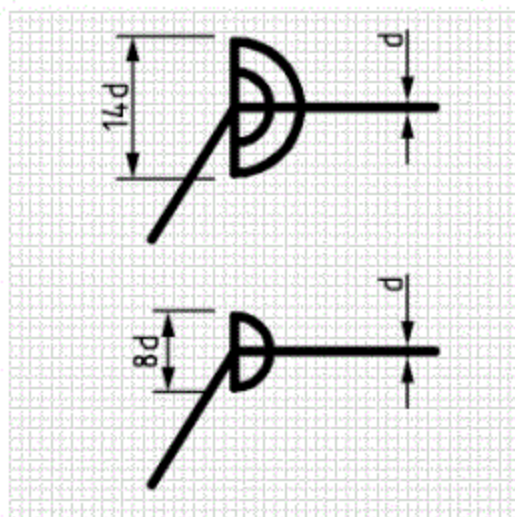


Figure A.13

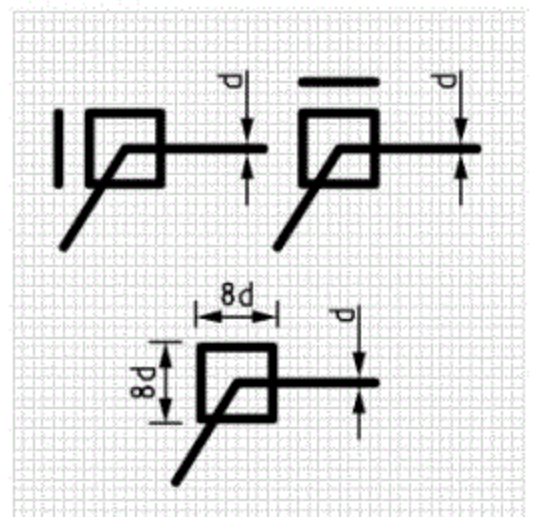


Figure A.14

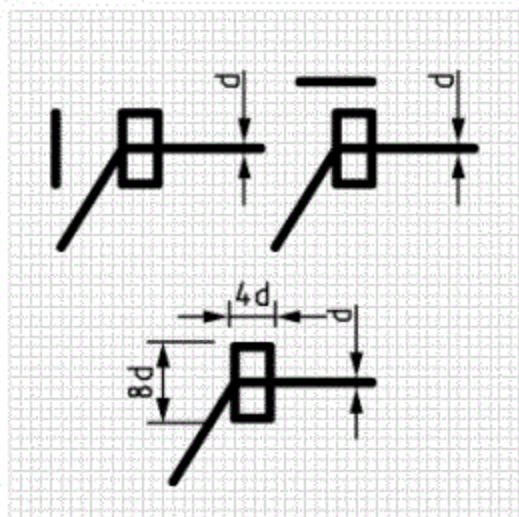


Figure A.15

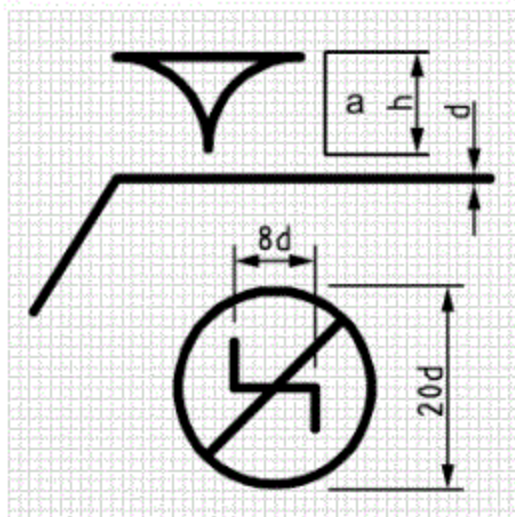


Figure A.16

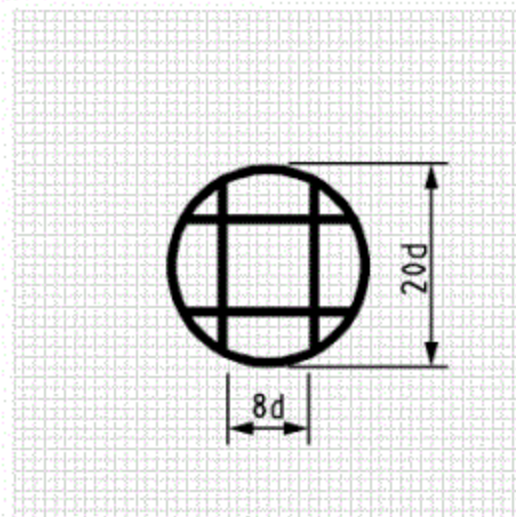


Figure A.17

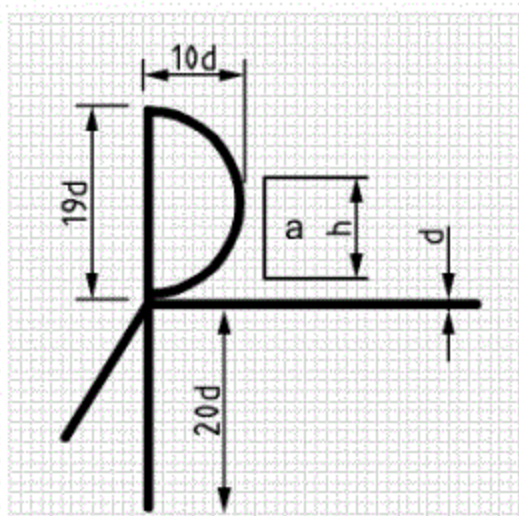


Figure A.18

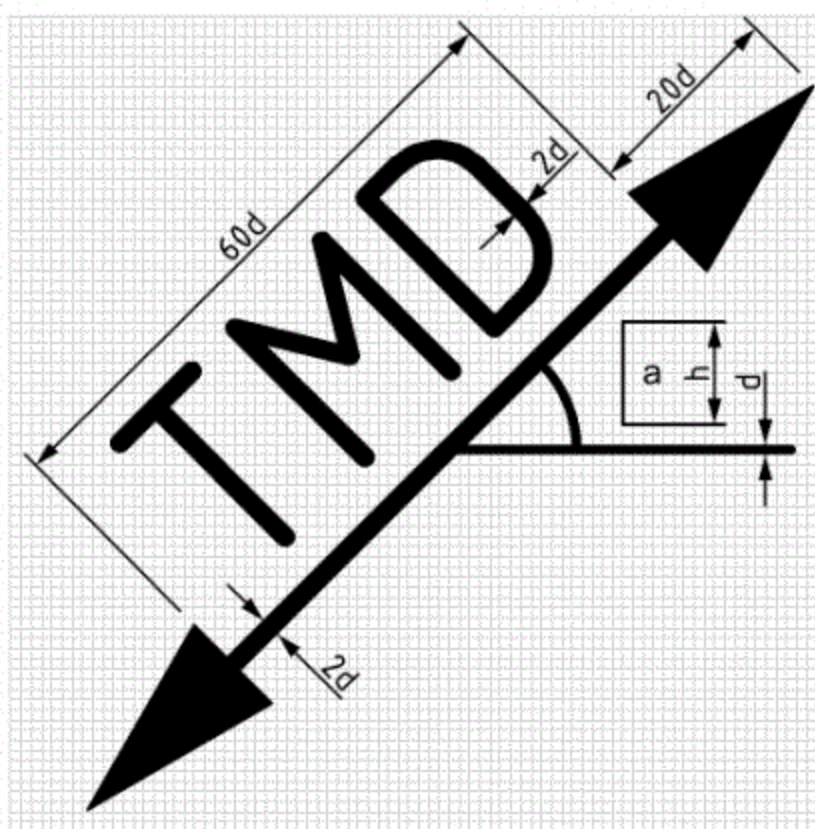


Figure A.19

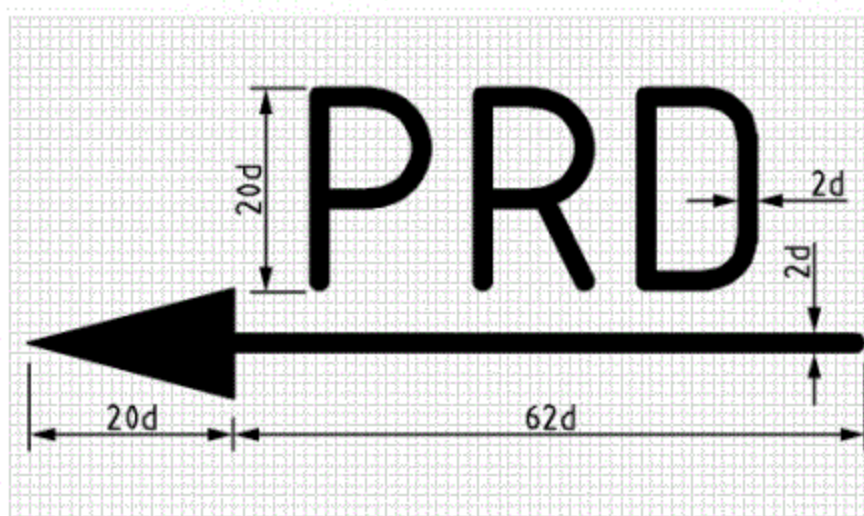


Figure A.20

A.4 Dimensions

The dimensional requirements of the graphical symbols and the additional indications are specified in Table A.1.

NOTE These requirements are in accordance with ISO 3098-1.

Table A.1 — Dimensions

Dimensions in millimetres						
Lettering height, h	2,5	3,5	5,0	7,0	10,0	14,0
Line thickness for symbols and lettering, d	0,25	0,35	0,5	0,7	1,0	1,4

Annex B
(informative)

Former practice (tapered features)

The following text was stated in Clause 8 of ISO 8062:1994 concerning tapered features. Its meaning has proven to be ambiguous and different, no converging interpretations exist. Consequently, it has been chosen only to repeat the content here and not to provide any explanations. Clause 8 of ISO 8062:1994 has been replaced by 6.7 of this International Standard where no material is to be removed on the tapered feature.

Where a design requires a tapered feature (e.g. feature with a draft angle), the tolerance shall be applied symmetrically along the surface (see Figure B.1).

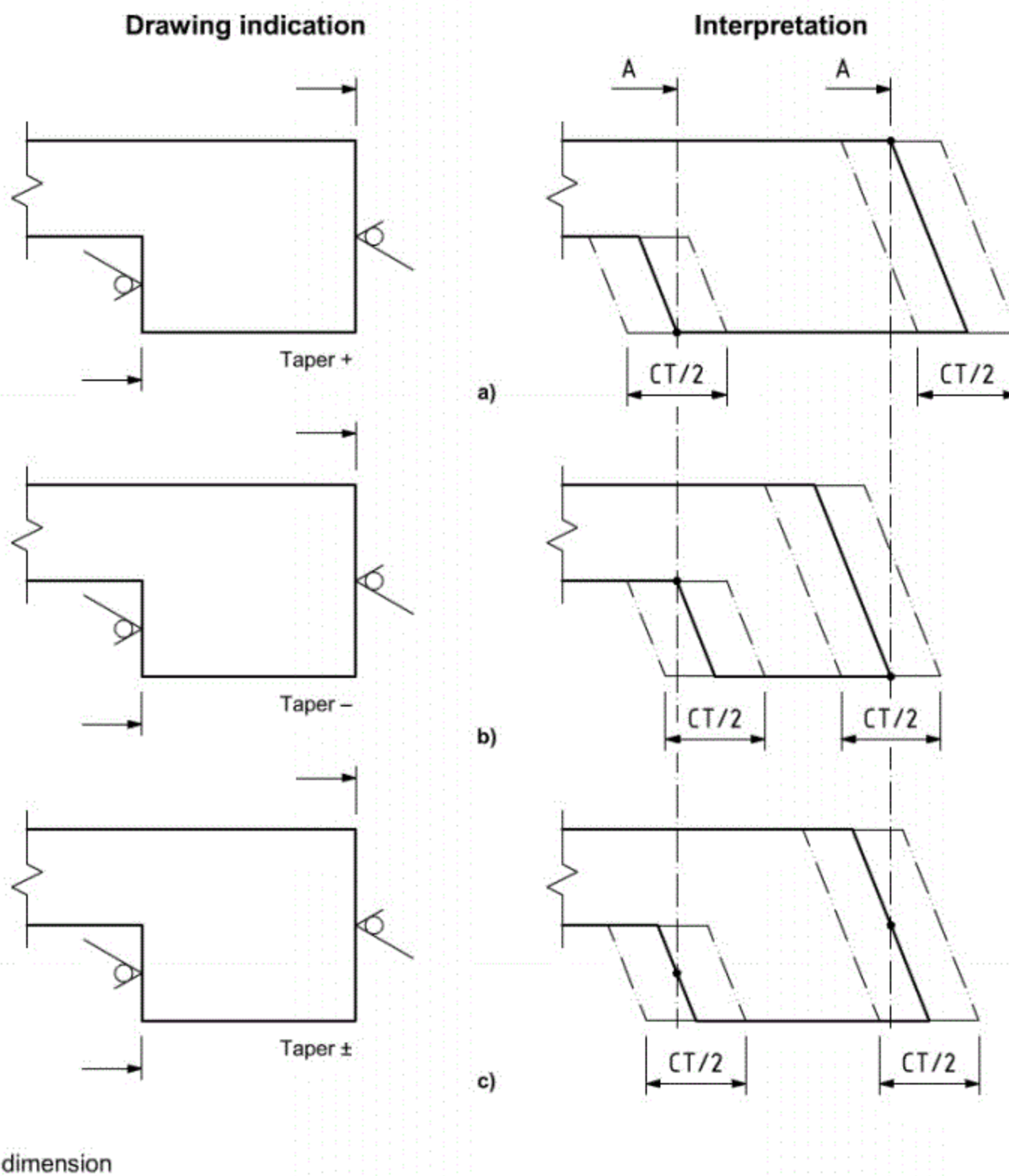


Figure B.1 — Tolerance zone on tapered features

The drawing shall specify generally whether the taper shall be added to, subtracted from or averaged to the material, e.g.:

- taper +, Figure B.1 a);
- taper −, Figure B.1 b);
- taper ±, Figure B.1 c).

Tapers for particular surfaces arranged differently from the general arrangement of taper of the drawing shall be indicated individually at the surface, e.g.



For dimensions to be machined, “taper +” shall be applied, irrespective of the general drawing specification for taper, in order that the finished dimensions be able to be achieved.

Annex C (informative)

Relation to the GPS matrix model

C.1 General

For full details about the GPS matrix model, see ISO/TR 14638.

C.2 Information about the International Standard and its use

This International Standard specifies rules and conventions for the indications of requirements for moulded parts on technical drawings. It also specifies the proportions and dimensions of the graphical symbols used for this representation. Use of linear dimensioning and tolerancing for moulded parts only controls features of size. Any other geometrical characteristics of type dimension are only controlled by geometrical tolerancing.

C.3 Position in the GPS matrix model

This International Standard is a technical product documentation (TPD) standard (as prepared by ISO/TC 10), but also serves as a geometrical product specification (GPS) standard (as prepared by ISO/TC 213) and is to be regarded as a complementary process specific tolerance GPS standard (see ISO/TR 14638). It influences chain links 1 and 2 of the chain of standards on mouldings, as graphically illustrated in Figure C.1.

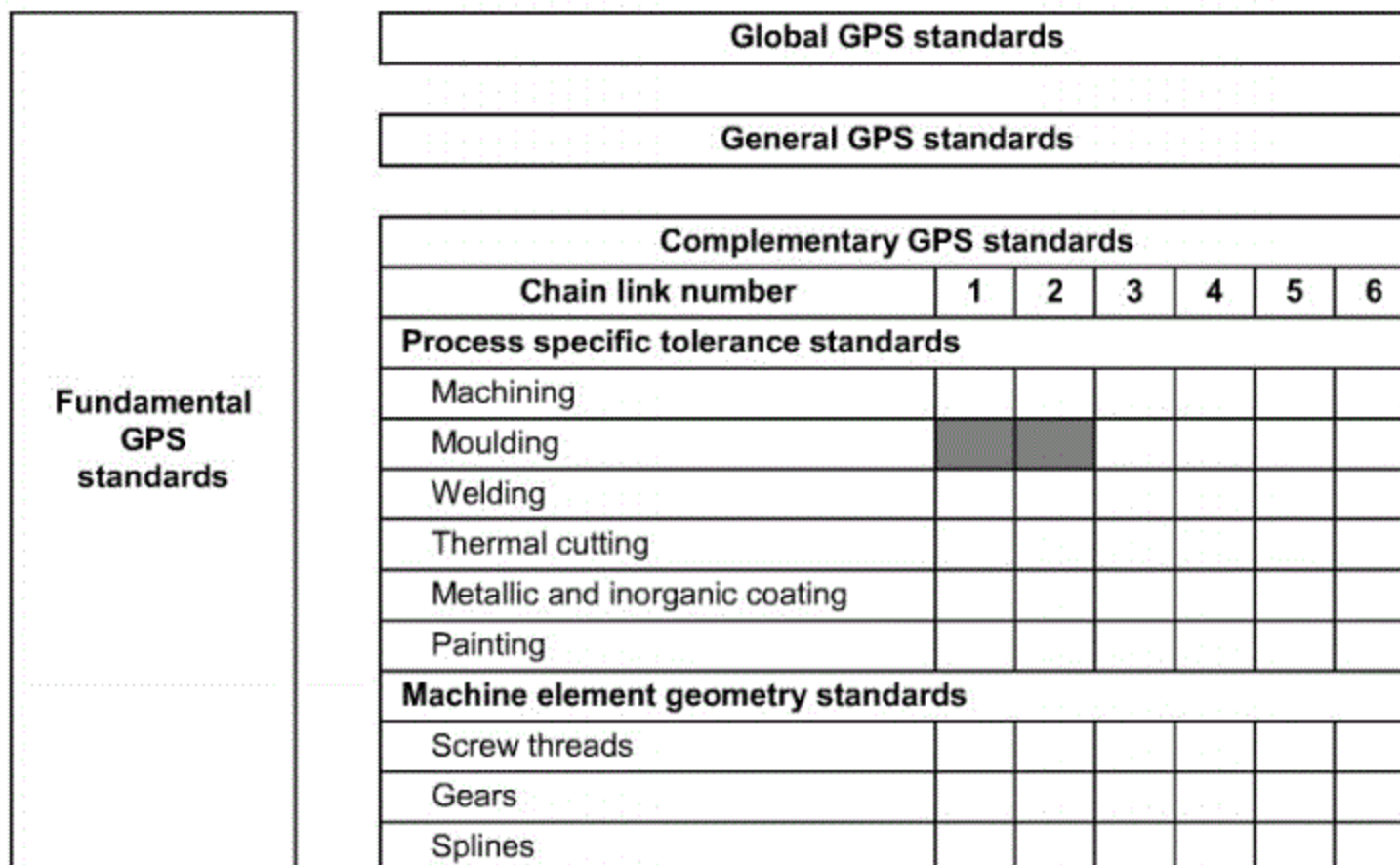


Figure C.1 — Position in the GPS matrix model

C.4 Related International Standards

The related International Standards are those of the chains of standards indicated in Figure C.1.

Bibliography

- [1] ISO 128-20:1996, *Technical drawings — General principles of presentation — Part 20: Basic conventions for lines*
- [2] ISO 8015:1985, *Technical drawings — Fundamental tolerancing principle*
- [3] ISO 8062:1994, *Castings — System of dimensional tolerances and machining allowances*
- [4] ISO 11971:1997, *Visual examination of surface quality of steel castings*
- [5] ISO 14405, *Geometrical product specifications (GPS) — Dimensional tolerancing — Linear sizes*
- [6] ISO 15787:2001, *Technical product documentation — Heat treated ferrous parts — Presentation and indications*

www.iso.org

ISO 10135:2007(E)

ICS 01.100.20

Price based on 51 pages

© ISO 2007 – All rights reserved

Copyright International Organization for Standardization
Not for Resale

Provided by IHS under license with ISO