

---

**Operating Instructions**

**P813**

**61-Key Multifunctional Performance  
LED Display Electric Grand Piano**

---

## Caution

Be sure to obey the following basic notice when play so as not to harm yourself or others and damage this instrument or other external equipment. These notice includes( but not limited to) the following.

### Warning:

- ◆Do not disassemble or modify this instrument in any way, otherwise it will cause the shock, scalding and personal injury risk. You should entrust the internal inspection, debugging and maintenance to your dealer or the place you bought it form.
- ◆If there is wet and tear occurs in power cord or power plug, or a sudden power failure when play, and occur the abnormal odour or smoking from the electronic grand piano, you should turn off the power, unplug the power plug immediately and find qualified repairman to carry out the overhauling.
- ◆Before cleaning the electric grand piano, you should turn off power and unplug the power plug, do not do the charged operation with wet hands. Do not wipe and clean the electric grand piano with corrosive solvent.
- ◆Do not put the electric grand piano on vibrating, slantwise or unstable surface, otherwise the electric grand piano may overturn to hurt human body. You should always ensure that you use the screws provided to fix the electric grand piano on the bracket. the electric grand piano may overturn from the bracket and cause the risk of personal risk if the electric grand piano is unstable.
- ◆Avoid the electric grand piano in rain or use it in the washy and wet place. Do not put the following objects on the electric grand piano.
  - Container (vase, potted plant, cup, cosmetic bottle or medicine bottle)are full of water or other liquid;
  - Small metal objects (including hairpin, sewing needle and coin);
  - The fire source of the naked fire, such as the lighted candle. Prevent the water,liquid,small metal objects and fire source from spraying out into this instrument,then,it may cause the fire disaster or electric shock.

### Caution:

- ◆Avoid placing the electric piano at the following places in order to avoiding damaging the electric piano and internal components:
  - The place of high temperature and much dust.
  - Kitchen or other places with oil fume.
  - The neighborhood of the air conditioner, The place where the sunlight shines directly or any other places that create high temperature promptly.
- ◆Do not place the electrical piano near other electric appliances,such as TV,radio,speakers,otherwise mutual disturbance between electric appliances may be incurred.Do not place heavy matter on the piano and do not use too large force to hit the keys or switches.
- ◆When you don't use the electrical piano for a long time,please remove power plug. And When you remove the power plug, please hold the plug instead of electric wire to pull it out.
- ◆Be sure to install bracket according to the instructions and fasten all connections. Moreover, Select Appropriate position to install the rack.
- When you place the electrical piano on the bracket,take care and not to let your fingers be clamped between the piano and rack.
- When you move the electrical piano,there should be two persons at least carrying together.The brackets may overturn and cause the risk of personal.
- Regularly examine whether screws are tightened.You should tighten them if you have found the loose screws.
- ◆Do not place power cord near heating source such as radiator etc. Do not over bend power cord.
- ◆Do not place heavy objects on power cord. Do not place power cord where people walk. Do not wrap other things around power cord in order to avoid damaging it.
- ◆Do not play music loudly for a long time. Be careful when use Headphone,because too high volume will easily hurt your audition.

## Appendix V. Technical Specifications

### ■Standard

- GB/T13837-2012 GB17625.1-2012  
GB8898-2011

### ■Polyphony

- 32pcs

### ■Display

- LED display

### ■Tone

- 300 kinds of tones

### ■Style

- 300 kinds of auto accompaniments

### ■Demo song

- 80 pcs of demo songs

### ■Effect control

- Touch, Split, Dual,Sustain,Metronome, Percussion

### ■Recording and programming

- Recording, Play back,program

### ■Accompaniment control

- Start/Stop, Sync,Fill-in,Intro/Ending,Variation

### ■Chord control

- Single chord 1, Single chord 2, Finger chord, Chord close, Bass chord

### ■Memory store

- 4 pieces memory storage M1~M4,can save tone, style and tempo data

### ■Learning

- One key teaching, following teaching, Ensemble teaching

### ■Other control

- Power Switch, Master Volume ,Accompaniment Volume ,Tempo

### ■External port

- DC 9V, Headphone Out ,Line Out ,Sustain Pedal, USB(MIDI)

### ■Accuracy in musical tuning

- ≤3 cents

### ■Diapason

- C2~C7

### ■Power

- DC9V,550-800mA

### ■Parts provided with electrical piano

- Mounting screw, Instruction,Power Adapter

## Appendix IV.Trouble Shooting

Trouble	Possible reason/eliminating method
Accompanying a little noise when turning ON/OFF power	Normal phenomenon. please do not worry.
After turning on power,press keyboard but no sound can be emitted.	Check whether volume control key is at proper position or headphone jack is held by other equipment to break off built-in speaker system.
Distorted or discontinued sound, or even system halted.	Using unqualified AC adapter.Please use the AC adapter provided with this electronic piano.
In a tone,note and note quality has the slight difference.	This is normal phenomenon caused by different tone sampling system of the electrical piano.
When using Sustain function, some tones have long sustain but some have short sustain.	This is normal phenomenon since the sustain setting of different tones of the electrical piano was best length.
Abnormal in volume or accompaniment volume	Check whether volume control and accompaniment volume control are in proper setting.
In SYNC status, auto accompaniment does not work.	Check whether Single chord or Finger chord is set, now pressing a note at left-hand keyboard area(19 keys in the left of keyboard)
When using AC adapter,the electronic piano does not emit sound after started up and there was anything display on the LED.	Check whether power socket is energized, AC adapter is well plugged, poor connection of power socket of inadequate power voltage.
The pitch of note is not correct.	Check whether the parameter of Transpose is "00".
When using mobile phone,the electronic piano will emit noise.	Mobile phone can disturb the electronic piano. To avoid the noise,turn off mobile phone or use it far away.

## Table of Contents

<b>Table of Contents</b> .....	<b>1</b>
Left Panel control.....	1
Right Panel control.....	1
Back Panel control.....	1
<b>Preparation before performance</b> .....	<b>2</b>
Power connection.....	2
Use of Pedal Sustain.....	2
Use of headphone.....	2
Connection with Amplifier or Hi-Fi Equipment.....	2
USB(MIDI) Jack.....	2
<b>Installation of piano body</b> .....	<b>3</b>
Turn on Power.....	4
Master Volume Adjustment.....	4
<b>Play the keyboard with different voice</b> .....	<b>4</b>
Tone Selection.....	4
Double Voice.....	4
Keyboard Split.....	4
Sustain.....	5
Vibration.....	5
Touch.....	5
Percussion.....	5
Metronome.....	5
Transpose.....	5
<b>Style function</b> .....	<b>6</b>
Selecting style.....	6
Accompaniment volume adjustment.....	6
Tempo adjustment.....	6
Start/stop.....	6
Intro/ending.....	6
Sync.....	6
Fill-in.....	6
Variation.....	6
<b>Mode of piano performance</b> .....	<b>7</b>
<b>Chord Accompaniment</b> .....	<b>7</b>
Single Chord 1.....	7
Single Chord 2.....	7
Finger Chord.....	7
Chord close.....	7
Bass Chord.....	7
<b>Status Memory</b> .....	<b>8</b>
<b>Recording Function</b> .....	<b>8</b>
<b>The play back to the demo</b> .....	<b>8</b>
<b>Intelligent Teaching</b> .....	<b>9</b>
<b>Appendix I, Table of Tone</b> .....	<b>10</b>
<b>Appendix II, Table of Style</b> .....	<b>12</b>
<b>Appendix III, Table of Demo song</b> .....	<b>14</b>
<b>Appendix IV, Trouble shooting</b> .....	<b>15</b>
<b>Appendix V, Technical specifications</b> .....	<b>16</b>

# Panel Control and External Function

## Left Panel Control

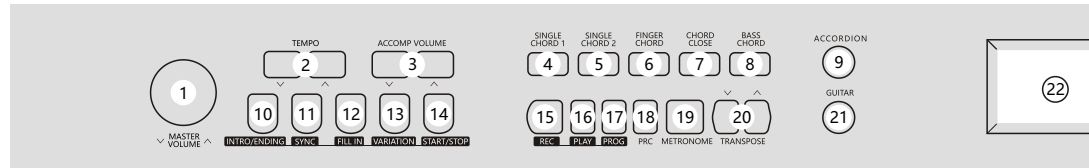

- 1.Master Volume
- 2.Tempo
- 3.Accomp Volume
- 4.Single Chord 1
- 5.Single Chord 2
- 6.Finger Chord
- 7.Chord Close
- 8.Bass Close
- 9.Accordion
- 10.Intero/ending
- 11.Sync
- 12.Fill-in
- 13.Variation
- 14.Start/Stop
- 15.Record
- 16.Play
- 17.Program
- 18.Percussion
- 19.Metronome
- 20.Transpose
- 21.Guitar
- 22.LED Display Screen

## Right Panel Control

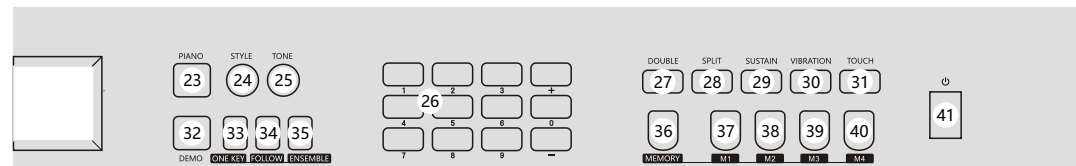

- 23.Piano
- 24.Style
- 25.Tone
- 26.Number 0~9/+/-
- 27.Dual
- 28.Split
- 29.Sustain
- 30.Vibration
- 31.Touch
- 32.Demo
- 33.One Key
- 34.Follow
- 35.Ensemble
- 36.Memory
- 37.M1
- 38.M2
- 39.M3
- 40.M4
- 41.Power Switch

## Back Panel control

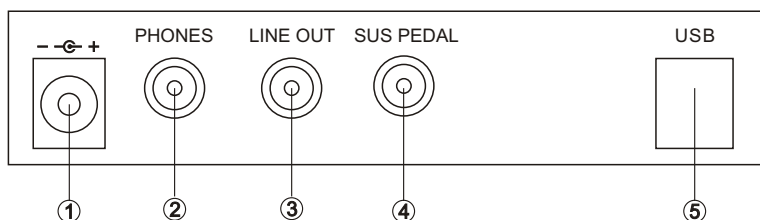

- 1.DC 9V
- 2.Headphone jack
- 3.Line out
- 4.Sustain Pedal
- 5.USB to device

# Appendix III. Table of Demo Song

No.	Code of song	No.	Code of song	No.	Code of song
0	Hey Pampow	27	Polonaise	54	Opus 40 by Mozart
1	Nocturne	28	Katyusha	55	Susanna
2	In the rain	29	Red River Valley	56	Fountain
3	Reed	30	Brandenburg Concertos	57	Maiden's Prayer
4	Air string music	31	Danse Russe	58	Four seasons spring
5	Canon	32	Chong Erfei	59	Swan Lake
6	The first Christmas 1	33	Toreador Song	60	Fur Elise
7	Coldness	34	The Cuckoo Waltz	61	William Tell Overture
8	Minuet in G	35	Old French song	62	Smile Polka
9	Entertainer	36	Habanera	63	Spain Matador March
10	Bach's Minute	37	Waltz of the Flowers	64	Turkish March
11	American Patrol	38	Fantasia from Chiop	65	Four Swans
12	Oh, the Christmas tree	39	Waltz in G flat major	66	Abide With Me
13	Oh, my dear Clementine	40	Island Of Capri	67	Spring Song
14	Rudolph the Red-Nosed Reindeer	41	Carmen	68	Minute Waltz Op
15	Silver	42	Carmen Aragon	69	Gavotte
16	Beethoven Sonata	43	Carmen Overture	70	Schubert Serenade
17	O sole mio	44	Cute little spider	71	Serenade - Haydn
18	Socks 2	45	Clementine sonata	72	Moments Musicaux
19	Winter	46	Croatian Rhapsody	73	Hungarian Dance
20	Long long ago	47	Radetzky March	74	Yankee Doodle
21	Romance De Amor	48	The Blue Danube	75	Waltz
22	Concerto D'Amour	49	Mariage D'Amour	76	The tragic third movement
23	Music Box Dancer	50	The Magic Flute-overture	77	Polka, Italy
24	Ann Polka	51	Mozart	78	Minuets
25	River of Babylon	52	Santa Claus is coming to town	79	Rhythm Of Rain
26	White Christmas	53	Silent Night		

## Appendix I. table of Style

No.	Name of style	No.	Name of style	No.	Name of style
186	Britpop2	224	New Orleans Blues	262	Middle East tango2
187	NewRock	225	New York Blues	263	Middle East tango3
188	Modern dance1	226	Piano Blues	264	Reggae March1
189	Modern dance2	227	Soul-Blues	265	Reggae March2
190	Modern dance3	228	Urban Blues	266	Reggae March3
191	Modern dance4	229	Blues waltz1	267	Reggae March4
192	Modern dance5	230	Blues merengue1	268	Classical polka
193	New century1	231	Blues merengue2	269	Mento
194	New century2	232	Contemporary R&B1	270	Political Reggae
195	New century3	233	Contemporary R&B2	271	Classical Waltz1
196	Rock Dance1	234	Contemporary R&B3	272	Classical Waltz2
197	Rock Dance2	235	Contemporary R&B4	273	Classical Waltz3
198	Jazz bachata1	236	Contemporary R&B5	274	Chinese Classical1
199	Jazz bachata2	237	Deep Funk	275	Chinese Classical2
200	Psychedelic 1	238	Doo Wop	276	Chinese Classical3
201	Psychedelic 2	239	Left-Field Hip-Hop	277	Chamber pop
202	Post Rock	240	Motown	278	Techno-Tribal
203	Soft Rock	241	Slow R&b1	279	Classical ballad1
204	Goth Psychedelic	242	Slow R&b2	280	Classical ballad2
205	SoulPsychedelic 1	243	Slow R&b3	281	Light ballad
206	SoulPsychedelic 1	244	Lyric R&b	282	Pop_classic
207	SoulPsychedelic 1	245	R&b march1	283	Britpo samba1
208	SoulPsychedelic 1	246	R&b march2	284	Britpo samba2
209	Psychedelic swing	247	Afro-Beat	285	Downtempo
210	Funky_soul1	248	Afro-Pop	286	Big Beat
211	Reggae soul1	249	Celtic Pop	287	Trip-Hop1
212	Reggae soul2	250	Hawaiian Pop	288	Trip-Hop2
213	Space	251	Indian Pop	289	Rhythm ballad
214	Free Psychedelic 1	252	European Traditions	290	Lyric step
215	Free Psychedelic 2	253	World Fusion	291	Lyric rhythm1
216	Free Psychedelic 3	254	Asia samba	292	Lyric rhythm2
217	Free Psychedelic 4	255	Traditional Reggae	293	Slow ballad1
218	Free jazz	256	Middle East tango1	294	Slow ballad2
219	Country Blues	257	Reggae-Pop	295	Xinjiang 1
220	Electric Blues	258	Roots Reggae	296	Xinjiang 2
221	Folk-Blues	259	ReggaeBeat1	297	Henan
222	Jazz Blues	260	ReggaeBeat2	298	Dongbei
223	Jump Blues	261	Dancehall	299	Shanbei

## Preparation before performance

### Power connection

1. Firstly, Make sure whether the power switch of Electrical piano is at OFF position. If not, pull the Switch to OFF position.

2. Connect the power cord: Insert power cord into power socket.

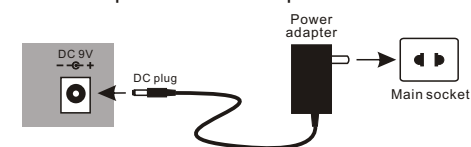

**Caution:** When you do not use this electrical piano, you should get out of the plug of AC power from power socket safely in order to avoid the obstacle of piano parts or other accident for the power is on for long time.

- Do not pull out power cord from power socket when the power is on.
- Fuse replacement shall only be made by qualified person.

### Use of Pedal Sustain

The function of sustain can produce natural sustain by stepping upon sustain pedal when you perform. Please insert the plug of sustain pedal into SUS PEDAL jack. You can open/close the sustain function through the sustain pedal plug.

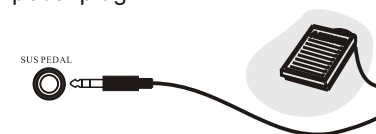

### Use of headphone

Insert headphone plug into "HEADPHONE" jack in the rear of electrical piano. At the same time internal speaker cuts off automatically. It does not interfere with anybody else, if you use headphone during performance, it is special for personal monitor and exercising at night.

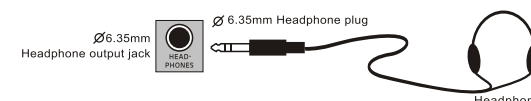

### Connection with Amplifier or Hi-Fi Equipment

This electrical piano has built-in speaker system. It can be connected with other external amplifier or speaker system. First turn off the power of electrical piano and external equipment, then insert one end of stereo audio cable into LINE IN or Aux IN jack of other hi-fi equipment and insert the other end into LINE OUT jack in rear panel of electronic piano.



### USB(MIDI)Jack





This digital piano supports one USB jack, it can be connected to personal computer directly. You only need one USB cable, one end is inserted into USB jack of this keyboard, another end is inserted into USB port of computer, it can transfer information between the piano and computer, which means that you can store the music that you had played on this keyboard to the computer, and you also can open and play MIDI document in your computer and the MIDI will be played from this keyboard as well.

Notice:

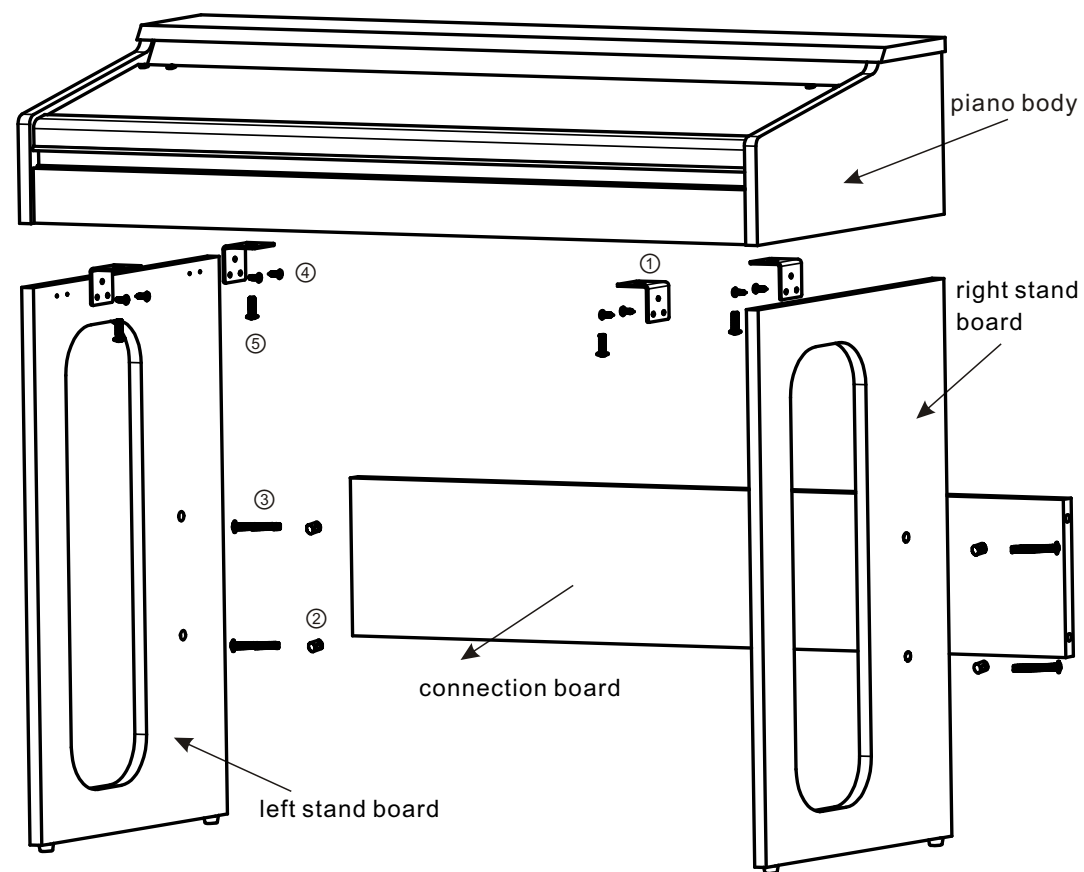
The USB audio equipment can not be set for input and output at the same time when you do the setting of the computer software, or else the sound will be overlapping when you play the keys. All the above external equipment are not equipped with this digital piano, the users need to buy by themselves. Please help to understand.

## Installation of piano body



- ①  Angle iron 4pcs
- ②  Nut screw 4pcs
- ③  Screw-TM6\*50 4pcs
- ④  Screw-TA4\*12 8pcs
- ⑤  Screw-TM6\*20 4pcs

1. Use 8 pcs TA4\*12 screws to fix the angle iron on the left and right stand board separately.
2. Fix the 4pcs of nut screw into the four holes of connection board.
3. Use the 4pcs of TM6\*50 screw to fix the connection board with the left and right stand board, then the stand is assembled ready.
4. Put the piano body on the wooden stand and use the 4pcs of TM6\*20 screw to fix it.

## Appendix I. table of Style

No.	Name of style	No.	Name of style	No.	Name of style
0	Beat1	62	Soul4	124	Mideast
1	Beat2	63	Soul5	125	Pop
2	Beat3	64	Newsoul	126	Love_ballad
3	Beat4	65	Big_band1	127	EasyBeat
4	Beat5	66	Big_band2	128	SoftBeat
5	Beat6	67	Blue_grass	129	Pop_samba1
6	Beat7	68	Jazz_samba	130	Pop_samba2
7	Beat8	69	Jazz_waltz1	131	Shuffle
8	Beat9	70	Jazz1	132	Jazz Band
9	Beat10	71	Jazz2	133	Shuffle1
10	Beat11	72	Swing1	134	Shuffle2
11	Beat12	73	Swing2	135	Slow folk
12	Beat13	74	Swing3	136	Step
13	Beat14	75	Jazz_waltz2	137	16ballad1
14	16beat1	76	Merengue1	138	16ballad2
15	16beat2	77	Merengue2	139	Love_ballad1
16	16beat3	78	Country1	140	Love_ballad2
17	Rock1	79	Country2	141	Swing1
18	Rock2	80	Country3	142	Swing2
19	SlowRock	81	Country4	143	Swing3
20	CntyRock	82	Country5	144	Reggae
21	DancRock	83	Country6	145	Rhumba1
22	EasyRock	84	Country7	146	Rhumba2
23	GlamRock	85	Cntrwal1	147	Rhumba3
24	HarRock1	86	Cntrwal2	148	Rhumba4
25	HarRock2	87	SlowCnt1	149	Salsa
26	PopRock	88	SlowCnt2	150	Samba1
27	RockRoll	89	SoulCntr	151	Samba2
28	RockBeat	90	Mambo1	152	Cobmo
29	RockFolk	91	Habanera	153	Jorpo
30	RockyPop	92	Vallenat	154	OrientalBeat1
31	HardRock	93	Baiao	155	OrientalBeat2
32	Had3Beat	94	Bequine	156	OrientalBeat3
33	Plena	95	Bolero	157	OrientalBeat4
34	Dance1	96	Bossanoval1	158	OrientalBeat5
35	Dance2	97	Lambada	159	OrientalBeat6
36	Dance3	98	Mambo	160	OrientalBeat7
37	Dance4	99	Samba	161	OrientalBeat8
38	Dance5	100	Reggae	162	OrientalBeat9
39	Dance6	101	Rhumba	163	OrientalBeat10
40	Dance7	102	Tango1	164	OrientalBeat11
41	Dance8	103	Bossanoval2	165	OrientalBeat12
42	Dance9	104	Bossanoval3	166	OrientalBeat13
43	Dance10	105	Bossanoval4	167	OrientalBeat14
44	Bachata1	106	Bossanoval5	168	Classical beat1
45	Bachata2	107	Calypso	169	Classical beat2
46	Soul_funk	108	Tango2	170	Classical beat3
47	Euro_soul	109	Tango3	171	JazzRock1
48	Funky_soul1	110	March1	172	JazzRock2
49	Funky_soul2	111	March2	173	Soft Rock
50	Funky_soul3	112	March3	174	Classic Rock
51	Funky_soul4	113	March4	175	Folk rock1
52	Funky_soul5	114	Polka1	176	Folk rock2
53	Slow_soul1	115	Polka2	177	WaltzRock
54	Slow_soul2	116	Polka3	178	Heavy metal rock1
55	Slow_soul3	117	Waltz1	179	Heavy metal rock2
56	Funky_soul6	118	Waltz2	180	70'Rock
57	Funky_soul7	119	Waltz3	181	80'Rock
58	Funky_soul8	120	China1	182	Middle Eastern rock
59	Soul1	121	China2	183	Traditional rock
60	Soul2	122	China3	184	Rock disco
61	Soul3	123	Thailand	185	Britpop1



## Appendix I. table of Tone

No.	Name of tone	No.	Name of tone	No.	Name of tone
186	Pizzicato Violin	224	Metal Sax	262	Orchestra Lead
187	Pizzicato Ensemble 1	225	Baritone Sax ensemble	263	Glockenspiel Lead
188	Pizzicato Ensemble 2	226	Crystal Sax	264	Bass Lead
189	Percussion band	227	Soft Baritone Sax	265	Fifths Lead
190	Baritone Synth Contrabass	228	Synth Baritone Sax	266	Wind Lead
191	Bass Flute	229	Heavy metal Sax	267	Atmosphere Lead
192	Distortion Contrabass	230	Church Oboe	268	Sharp Lead
193	Contrabass Lead	231	Oboe ensemble	269	Bright Lead
194	Violin Lead	232	Bass Oboe	270	East Nation Pad
195	Cello Lead	233	Bright Oboe	271	Atmosphere Pad
196	Pizzicato rhythm	234	distortio oboe	272	Electric bass Pad
197	high Harp	235	English Horn ensemble	273	electric Piano Pad
198	Harp ensemble	236	Pizzicato English Horn	274	Clean Guitar Pad
199	Synth Harp	237	Diplophonia English Horn	275	Western Pad
200	Baritone Trumpet	238	Bright English Horn	276	Sci-fi Pad
201	Trumpet ensemble	239	Synth English Horn	277	Metal Sci-fi Pad
202	rhythm Trumpet	240	Psychedelic Synth Lead	278	Clarinet Pad
203	high Trumpet	241	Vibraphone Synth Lead	279	Electronic dance Pad
204	Synth Trumpet	242	Marimba Synth Lead	280	Double Kalimba
205	Bass Trombone	243	Metal FX	281	Bright Kalimba
206	Trombone ensemble	244	Electronic FX	282	Crystal Kalimba
207	rhythm Trombone	245	Electronic String Ensemble	283	Synth Kalimba
208	high Trombone	246	Wind FX	284	Electronic Bagpipe
209	baritone Trombone	247	Clarinet FX	285	Wind Bagpipe
210	Synth Trombone	248	Organ FX	286	high Bagpipe
211	Violin French Horn	249	Crystal FX	287	Bright Bagpipe
212	French Horn ensemble	250	Synth Shamisen	288	Orchestra Bagpipe
213	Electronic French Horn	251	Electronic Shamisen	289	Bangdi
214	Synth French Horn	252	Bright Sitar	290	Pipa
215	PsychedelicSynth Brass	253	Whistle Accord	291	Erhu
216	Distortion Synth Brass	254	rhythm Nation	292	Gaohu
217	Vibraphone Synth Brass	255	Bright Koto	293	Suona
218	Rock Synth Brass	256	Koto Lead	294	Dasuo
219	Synth Muted Trumpet	257	Diplophonia Koto	295	Guzheng
220	Soprano Sax ensemble	258	Baritone Koto	296	Sanxian
221	Hit Soprano Sax	259	Synth Koto	297	Guqin
222	Synth Soprano Sax	260	Environmental Lead	298	Xiao
223	National Sax	261	Metal Lead	299	China Percussion

### Turn on power

Press [POWER] button to turn on power, press it again to turn off power of electrical piano.



### Master Volume Adjustment

After turn on the piano, turn the [MASTER VOLUME] button to the right, adjust the volume from small to big. Users can do the suitable adjustment on the whole volume which depends on their requirement .



### Play the keyboard with different voice

#### Tone Selection

There is 0~299 , total 300 kinds of voice for your choice. The detailed voice, please refer to the tone list.

The default status is [TONE], when the electrical piano is open.

If current status is not TONE. you need to press [TONE] button.

And you can select voice by pressing the number 0~9 number or "+" , "-" button. The LED display will show the number that you choose.

If you select the voice by pressing the three numbers and the number is above 300, it is not effective and the voice will resume to the previous one.

TONE



### Effect & Control

#### Double Voice

Under normal status, press [DOUBLE] button, the digital piano enters the model of dual voice. Namely each note is composed of two voices. The first voice is the voice before you pressed [DOUBLE] button, and the second voice is the selected voice after pressed [DOUBLE] button.

If the function is off, LED display shows "dbl/Off", the voice will resume to the current voice.

DOUBLE



#### Keyboard split

Press [SPLIT] button, from the left 24th button, the keyboard forms left and right two tone keyboards. In 'tone' mode, press number or "+/-" button to adjust voice for right zone keyboards. Press [SPLIT] button again, exit the function. The keyboard resume to the voice of low key area.

The display shows "SPL/Off".

SPLIT



## Sustain

Press [SUSTAIN] button to start sustain function. It will produce prolonged effect if you play with B/W keys at the same time. Press [SUSTAIN] button again to exit the function.

SUSTAIN



## Vibration

Press [VIBRATION] button to start vibration function. It will produce the aquiver effect tone if you play with B/W keys at the same time. Press [VIBRATION] button again to exit the function.

VIBRATION



## Touch

This electrical piano is touch keyboard. When the piano is open, touch function starts automatically. When you play keyboard with different force, the electrical piano will play different size volume. Press [TOUCH] button, the touch function exits and keyboard touch is canceled. Press [TOUCH] button once again to restart touch function.

TOUCH



## Percussion

Press the [PRC] button. The Beat voice be produced. Then each key correspond to each percussion, total 61 kinds of percussion. Press [PRC] button again, exit the beat function.

PRC



## Metronome

Press [METRONOME] button, the tick-tock beat sound will occur. Here are four kinds of beats can be chosen, 1/4, 2/4, 3/4, 4/4. Press this button again, it goes into the next kind of beat. The LED has the relative display. Press [METRONOME] button to exit this function.

METRONOME



## Transpose

Press [TRANSPOSE] button + or - to increase or decrease the transpose value up “^” and down “v”, 6 levels and shift the pitch of entire keyboard up and down in semitone intervals. Press the ^/v buttons simultaneously to return to default status of keyboard tone.

TRANSPOSE

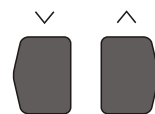

## Appendix I. table of Tone

No.	Name of tone	No.	Name of tone	No.	Name of tone
0	Acoustic Grand Piano	62	Synth Brass 1	124	Telephone Ring
1	Bright Acoustic Piano	63	Synth Brass 2	125	Helicopter
2	Electric Grand Piano	64	Soprano Sax	126	Applause
3	Honky-tonk Piano	65	Alto Sax	127	Gunshot
4	Rhodes Piano	66	Tenor Sax	128	Percussion
5	Chorused Piano	67	Baritone Sax	129	Rhythm electric Piano
6	Harpsichord	68	Oboe	130	Baritone Xylophone
7	Clavichord	69	English Horn	131	Clean Piano
8	Celesta	70	Bassoon	132	Bright Dulcimer
9	Glockenspiel	71	Clarinet	133	Rhythm Grand Piano
10	Music box	72	Piccolo	134	Traditional Piano
11	Vibraphone	73	Flute	135	Aluminium jean
12	Marimba	74	Recorder	136	Rock Grand Piano
13	Xylophone	75	Pan Flute	137	Electronic organ
14	Tubular Bells	76	Bottle Blow	138	Psychedelic electronic
15	Dulcimer	77	Shakuhachi	139	Water jean
16	Hammond Organ	78	Whistle	140	Bright Guitar
17	Percussive Organ	79	Ocarina	141	Orchestra piccolo
18	Rock Organ	80	Lead 1 (square)	142	Heavy metal guitar
19	Church Organ	81	Lead 2 (sawtooth)	143	Crystal guitar
20	Reed Organ	82	Lead 3 (caliope lead)	144	Queer electric Piano
21	Accordian	83	Lead 4 (chiff lead)	145	Bright bass
22	Harmonica	84	Lead 5 (charang)	146	Rock Electric Bass
23	Tango Accordian	85	Lead 6 (voice)	147	Psychedelic Bass
24	Acoustic Guitar (nylon)	86	Lead 7 (fifths)	148	Rhythm Electric Bass
25	Acoustic Guitar (steel)	87	Lead 8 (bass+lead)	149	Heavy metal bass
26	Electric Guitar (jazz)	88	Pad 1 (new age)	150	Magic electronic
27	Electric Guitar (clear)	89	Pad 2 (warm)	151	Bright violin
28	Electric Guitar (muted)	90	Pad 3 (polysynth)	152	Atonic violin
29	Overdriven Guitar	91	Pad 4 (choir)	153	Heavy bass orchestra
30	Distortion Guitar	92	Pad 5 (bowed)	154	Synth clarinet
31	Guitar Harmonics	93	Pad 6 (metallic)	155	Interactive Lead
32	Acoustic Bass	94	Pad 7 (halo)	156	orchestral keyboard
33	Electric Bass (finger)	95	Pad 8 (sweep)	157	Bagpipes
34	Electric Bass (pick)	96	FX 1 (rain)	158	Synth Banjo
35	Fretless Bass	97	FX 2 (soundtrack)	159	Japan Synth
36	Slap Bass 1	98	FX 3 (crystal)	160	Church Piano
37	Slap Bass 2	99	FX 4 (atmosphere)	161	Church electric Piano
38	Synth Bass 1	100	FX 5 (brightness)	162	Synth Piano
39	Synth Bass 2	101	FX 6 (goblins)	163	Baritone Piano
40	Violin	102	FX 7 (echoes)	164	Piano PAD
41	Viola	103	FX 8 (sci-fi)	165	String Piano
42	Cello	104	Sitar	166	Metal Piano
43	Contrabass	105	Banjo	167	Light rhythm Piano
44	Tremolo Strings	106	Shamisen	168	Electric Piano Pad
45	Pizzicato Strings	107	Koto	169	Classical piano
46	Orchestral Harp	108	Kalimba	170	Organ Guitar
47	Timpani	109	Bagpipe	171	Electric Guitar
48	String Ensemble 1	110	Fiddle	172	Synthesis Nylon Guitar
49	String Ensemble 2	111	Shanai	173	Synth Electronic Guitar
50	Synth Strings 1	112	Tinkle Bell	174	Bright Clean Guitar
51	Synth Strings 2	113	Agogo	175	Orchestra Guitar
52	Choir Aahs	114	Steel Drums	176	Psychedelic Guitar
53	Voice Oohs	115	Woodblock	177	Bright organ
54	Synth Voice	116	Taiko Drum	178	Pick organ
55	Orchestra Hit	117	Melodic Tom	179	Synth accordion
56	Trumpet	118	Synth Drum	180	Bright Violin
57	Trombone	119	Reverse Cymbal	181	Stringed violin
58	Tuba	120	Guitar Fret Noise	182	Trill violin
59	Muted Trumpet	121	Breath Noise	183	Electronic violin
60	French Horn	122	Seashore	184	Large violin
61	Brass Section	123	Bird Tweet	185	Rhythm Orchestra



## Intelligent Teaching

Press the [ONE KEY],[FOLLOW] or [ENSEMBLE] button to enter the teaching function then press the number keys or the  $\wedge/\vee$  button to select different teaching Songs.

Press the one key teaching button once again to exit this function.

1. One key teaching : Only there is key pressed, then the demo will be continued. Otherwise, the demo will be stopped. No matter you play correctly or not, the song will be automatically played continuously.
2. Following teaching: The main part of demo will be recovered. Follow the display to play the note correctly, then play the next note which is shown automatically on display.
3. Ensemble teaching: The main part of demo will be recovered, similar as Karaoke, the demo song will not be stopped, if there is no any pressing on the keyboard within 5 seconds, the main part of demo will resume to play. After learning one song, you will repeat to learn the current song. You also can choose your favorite song to learn.

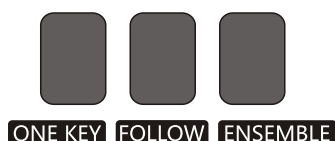

## Style Function

### Selecting Style

This electrical piano has 300 kinds of style for your choice. For style table, please refer it to detailed Appendix. Press [STYLE] button to enter Style selection function. LED displays current style number. The default style is "000". You can select the style by pressing the number 0~9 buttons directly or press "+/-".

STYLE



### Accompaniment volume adjustment

The default Accompaniment Vol is 16, you can adjust Accompaniment Vol by pressing [ACCOMP VOLUME] " $\wedge/\vee$ " button. The LED has the relative display when you adjust. The system will restore the default Accompaniment Vol automatically if you press the Accompaniment Vol " $\wedge$ " and " $\vee$ " button at the same time. The default volume is 16 after the power is on.

ACCOMP VOLUME



### Tempo Adjustment

Press [TEMPO]  $\wedge/\vee$  buttons, it can adjust the playback tempo of style, metronome, demo song. The adjustment range is 30-240, the default is "120" after the power is on. The system will restore the default tempo automatically if you press the TEMPO " $\wedge$ " and " $\vee$ " button at the same time.

TEMPO



### Start/Stop

In default status when the piano is open, press the [START/STOP] button to play STYLE. Press [START/STOP] button again, It can exit other functions.

### Intro/Ending

When you press [INTRO/ENDING] button before starting the style, an intro will be played, and then it continues to play after restored to the normal style, when you press [INTRO/ENDING] button during style playback, the style playback will be finished after a paragraph of ending is played.

### Sync Function

Press [SYNC] button to start sync accompaniment function and press any key of 19 keys in left hand to start style synchronously. If chord function is started, press relevant key of 19 keys in chord area to start auto chord synchronously. If a style is being played previously. Press [SYNC] button to stop style and start sync accompaniment function. If sync function has been started, press [SYNC] button to exit sync function. At the status of Sync, the red point as LED shows will be flashed with style. At the status of Sync, you can press [INTRO/ENDING], and press any key of 19 keys in left hand, then the style will start to play from intro.

### Fill-in

Press [FILL-IN] button to insert a intermezzo during style playback as to enhance the performance effect, after finishing the inserted style, the piano will continue to play the original style.

### Variation

At the mode of style, press [VARIATION] button, the piano will play the style with an style of variation. Press [VARIATION] button to exit this function.

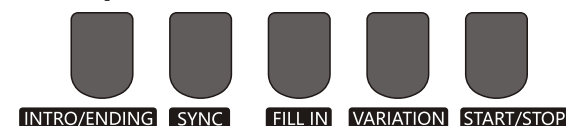

## Mode of piano performance

The digital piano designed this function specially. It can let you choose the Piano mode quickly when at other status.

1. Press the [PIANO] button, it can enter or exit the piano performance directly.
2. At the mode of piano performance, the method to choose the style is the same as other mode.

PIANO



## Chord Accompaniment

### Single Chord 1

When style is started, press [SINGLE CHORD 1] button to enter the function of single finger auto chord. Now in 1~19 keys of chord area, applying different fingerings to hear different chord Accompaniments, press [START/STOP] button to exit this function. Please refer to the chord program as below.

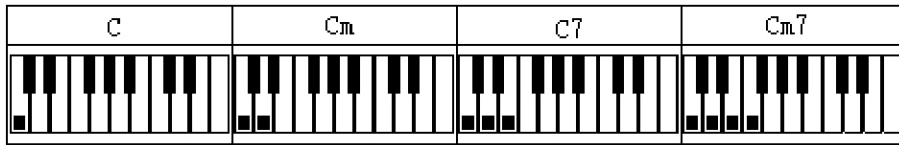

### Single Chord 2

When style is started, press [SINGLE CHORD 2] button to enter the function of single finger auto chord. Now in 1~19 keys of chord area, applying different fingerings to hear different chord Accompaniments, press [START/STOP] button to exit this function. Please refer to the chord program as below.

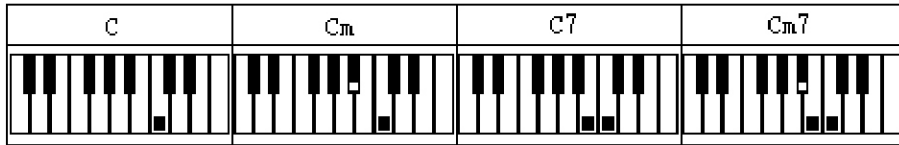

## Finger chord

When style is started, press [FINGER CHORD] button to enter the function of fingered auto bass chord. Now in 1-19 keys of chord area, applying different fingerings to hear different chord accompaniments. Press [START/STOP] button to exit this function.



## Chord Close

Under chord state, press [CHORD CLOSE] button to stop chord accompaniment while style continues to play.

## Bass Chord

At the mode of chord, press the [BASS CHORD] button to create an effective of heavy bass; press the [BASS CHORD] button again to exit the function.



## Status memory

This electronic piano has panel registration memory function, it can be used for saving your most favorite setting as to the setting can be tuned out easily and promptly when you need it. After you have adjusted the voice, style and tempo, press the [MEMORY] button, and press any of the [M1-M4] button, then the current voice, style and tempo will be recorded. Tune out stored panel setting: Pressing any of the [M1-M4] button that had been recorded in previous.



## Recording Function

1. Press [REC] button to enter recording model. You can hear metronome sounds and the default tempo is 120. Now press any button or drum key to start recording. The maximum recording quantity is 180. When the maximum quantity is full, metronome sound will stop and record cannot be continued. Every time you press this button, the memory in previous recorded will be cleared and the piano will enter into the recording model again.

2. Press [PLAY] button to play the recorded notes.

3. Press [PROG] button to enter into style programming mode, press keyboard to program a paragraph of style. This edited style can record 32pcs drum points at the most. Press [PLAY] button to play the edited drum sound in sequence, forming a kind of self-made style after programming is finished. The best style play effect can be got by adjusting [TEMPO ^/v] buttons. Every time, you press [PROG] button, it will clear last memory and enter into programming mode again.



## The Play back of the Demo

The total demo songs is 80pcs.

Press [DEMO] button to play song. Press this button again, It will play the next song. (Please refer the 14<sup>th</sup> page DEMO Appendix). Press [START/STOP] button, the playback of the Demo will stop.



DEMO