

●TCXO DIP-08 (电气参数):

Normal Frequency/频率范围	9.6MHZ~40.000MHZ		
Normal Frequency/常规频率	10MHZ/16.368MHZ/19.2MHZ/20MHZ/22.5792MHZ/32.768MHZ		
Supply Voltage/工作电压	3.3V/5M/12V		
Frequency Tolerance/25±3℃/调整偏差 25±3℃	±0.5PPM/±1PPM/±2PPM		
Operation Temperature Range/工作温度	-40℃ ~ +85℃		
14.Storage Temperature/存储温度	-55℃ ~ +125℃		
Duty Cycle/占空比	45/55 Standard		
Auto Frequency Control Range/频率控制范围	± 7 ~ ± 16 ppm (1.4+/- 1V)		
Current Consumption/功耗	2.0mA Max		
Aging 25±3℃ /年老化率	±1PPM/year	Phase Noise/相位噪声	130dBc/Hz at 1KHz offset
Output Load /输出负载(电阻/电容)	10KΩ/ 10 pF	Start Up Time 启动时间	5ms max
Frequency Stability 频率变动特征	Vs Temperature(-40~+85 ℃)温度	±0.5 ppm / ± 2.0 ppm	
	Supply Voltage (Vcc=Typical ±0.1V)电压	± 0.2 ppm max.	
	Load (Load varies ±10%)负载	± 0.2 ppm max. (10KΩ / 10pF±10%)	

●DIMENSIONS SPECIFICATIONS (外形尺寸)

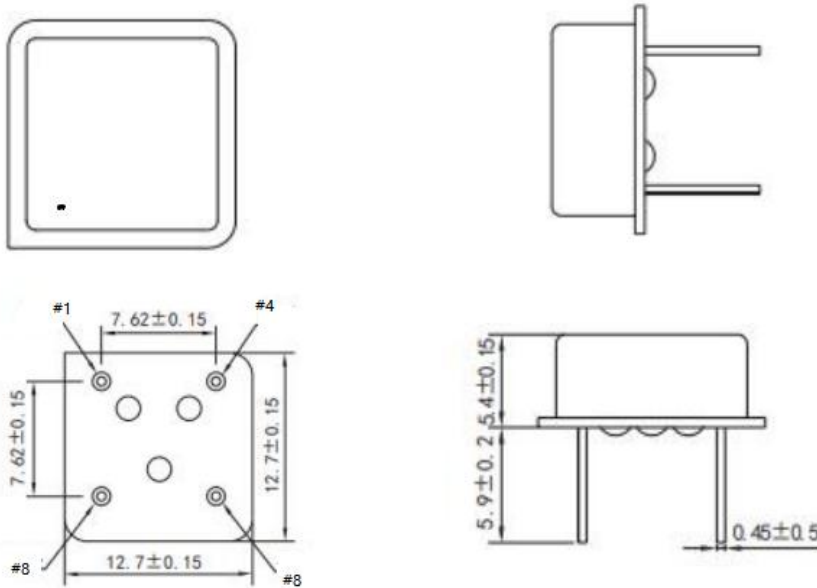

脚位 PIN	脚位连接 Connection	
	TCXO	VCTCXO
1	N.C.	Vc
4	GND	GND
5	OUT	OUT
8	Vcc	Vcc

Unit:mm

●Test Circuit(测试电路)

●Reflow Condition(回流焊条件)

