



### 1.1 性能特点

该系列减速机专为双轴桨叶式混合机设计。采用双空心轴输出方式，最大程度的节省了安装空间和生产成本，因而设备运行更加平稳、高效。该系列减速机采用四级齿轮传动，齿轮材料为低碳合金钢，采用渗碳淬火，磨齿等工艺，齿轮齿面硬度达58-62HRC，齿轮精度达到6级（ISO1328）。与国内外同类产品相比具有体积小，重量轻，使用可靠，维修方便，使用寿命长等特点。

### 1.2 应用场合

双轴桨叶式混合机广泛应用于干粉砂浆，化工，农药，陶瓷，食品，饲料及电池等行业。设备工作时，双轴相对反向旋转带动不同角度的桨叶将物料沿轴向、径向循环翻动，在高线速度的作用下物料被抛起处于失重（即无重力）状态后落下，抛起和落下时物料交叉混合达到均匀。

### 1.1 Performance and features

This series reducer is designed for two-axis blade mixer. The output mode of double hollow shafts, maximum savings in installation space and production costs, as a result, the equipment runs more smoothly and efficiently. The series reducer is driven by four-stage gears. The gear material is low-carbon alloy steel. Carburizing, quenching and grinding are adopted. The hardness of the gear surface reaches 58-62HRC, and the gear accuracy reaches 6 levels (ISO1328). Compared with similar products at home and abroad, it has the characteristics of small size, light weight, reliable use, convenient maintenance and long service life, etc.

### 1.2 Application occasion

Biaxial blade mixer is widely used in dry mortar, chemical industry, pesticides, ceramics, food, feed and battery industries. When the equipment works, biaxial relative reverse rotation drives the blades with different angles to turn the material along the axial and radial cycles. Under the action of high linear velocity, the material is thrown up and falls in a weightless (i.e. weightless) state. When the material is thrown up and fallen, the cross-mixing of the material reaches uniformity.



4.1 型号 / Model : THB4L570-AM180-35

4.2 技术参数 / Technical parameters

|  |                     |
|--|---------------------|
| 中心距 / Center distance  | 570 mm              |
| 电机 / Motor   | 18.5kW-4P / 22kW-4P |
| 速比 / Ratio   | 35                  |
| 输出转速 / Output speed  | 41 rpm              |
| 适用于 0.5 立方米 - 0.75 立方米无重力双轴搅拌机<br>For 0.5 m <sup>3</sup> - 0.75 m <sup>3</sup> gravity-free two-axis mixer |                     |

4.3 安装尺寸图 / Installation figure

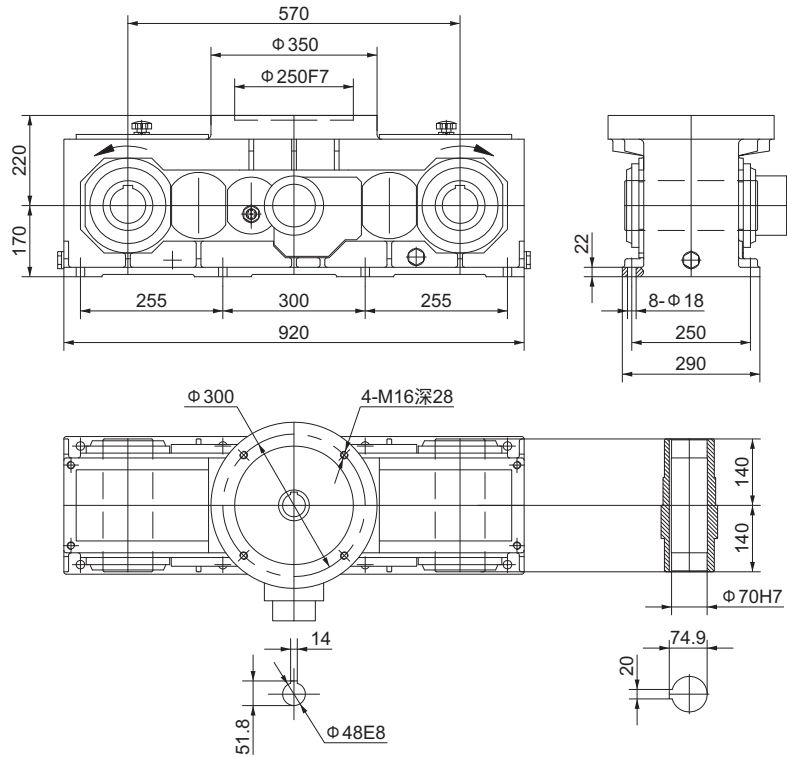

5.1 型号 / Model : THB4L700-AM180-33

5.2 技术参数 / Technical parameters

|  |                     |
|--|---------------------|
| 中心距 / Center distance  | 700 mm              |
| 电机 / Motor   | 18.5kW-4P / 22kW-4P |
| 速比 / Ratio   | 33                  |
| 输出转速 / Output speed  | 45 rpm              |
| 适用于 1 立方米 - 1.5 立方米无重力双轴搅拌机<br>For 1 m <sup>3</sup> - 1.5 m <sup>3</sup> gravity-free two-axis mixer |                     |

5.3 安装尺寸图 / Installation figure

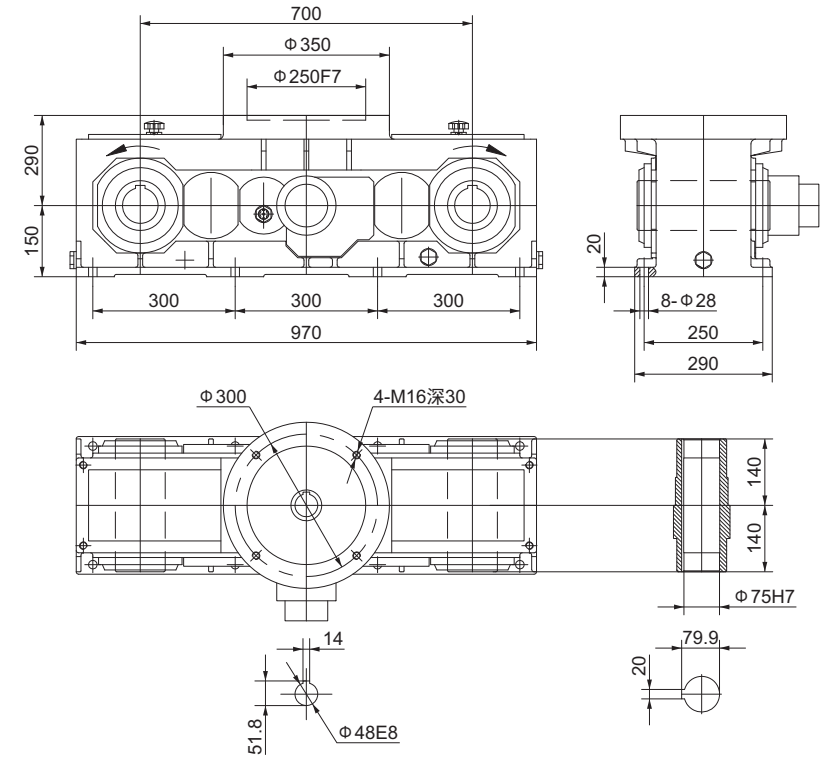



6.1 型号 / Model : THB4L890-AM200-50

6.2 技术参数 / Technical parameters

|  |         |
|--|---------|
| 中心距 / Center distance  | 890 mm  |
| 电机 / Motor   | 30kW-4P |
| 速比 / Ratio   | 50      |
| 输出转速 / Output speed  | 30 rpm  |
| 适用于 2 立方米 - 4 立方米无重力双轴搅拌机<br>For 2 m <sup>3</sup> - 4 m <sup>3</sup> gravity-free two-axis mixer |         |

6.3 安装尺寸图 / Installation figure

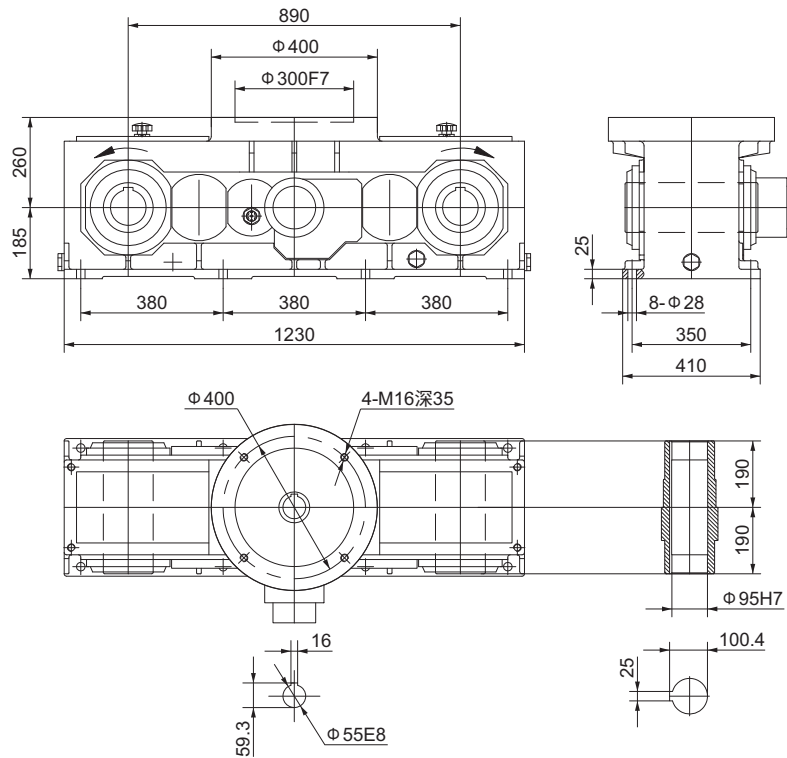

7.1 型号 / Model : THB4L890-AM225-50

7.2 技术参数 / Technical parameters

|  |         |
|--|---------|
| 中心距 / Center distance  | 890 mm  |
| 电机 / Motor   | 37kW-4P |
| 速比 / Ratio   | 50      |
| 输出转速 / Output speed  | 30 rpm  |
| 适用于 2 立方米 - 4 立方米无重力双轴搅拌机<br>For 2 m <sup>3</sup> - 4 m <sup>3</sup> gravity-free two-axis mixer |         |

7.3 安装尺寸图 / Installation figure

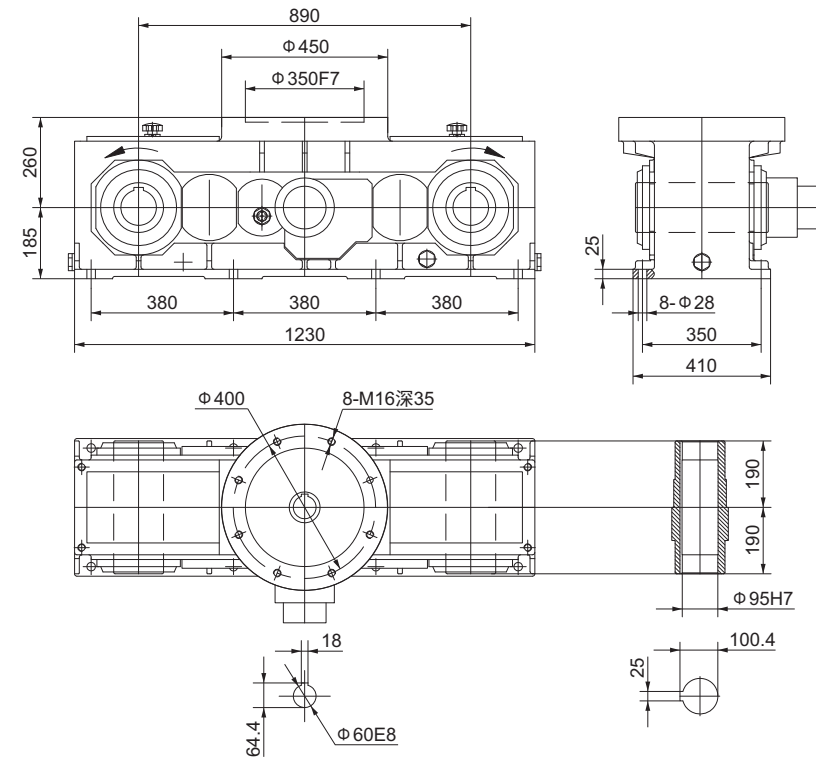



8.1 型号 / Model : THB4L1050-AM225-50

8.2 技术参数 / Technical parameters

|  |         |
|--|---------|
| 中心距 / Center distance  | 1050 mm |
| 电机 / Motor   | 45kW-4P |
| 速比 / Ratio   | 50      |
| 输出转速 / Output speed  | 30 rpm  |
| 适用于 6 立方米 - 8 立方米无重力双轴搅拌机<br>For 6 m <sup>3</sup> - 8 m <sup>3</sup> gravity-free two-axis mixer |         |

8.3 安装尺寸图 / Installation figure

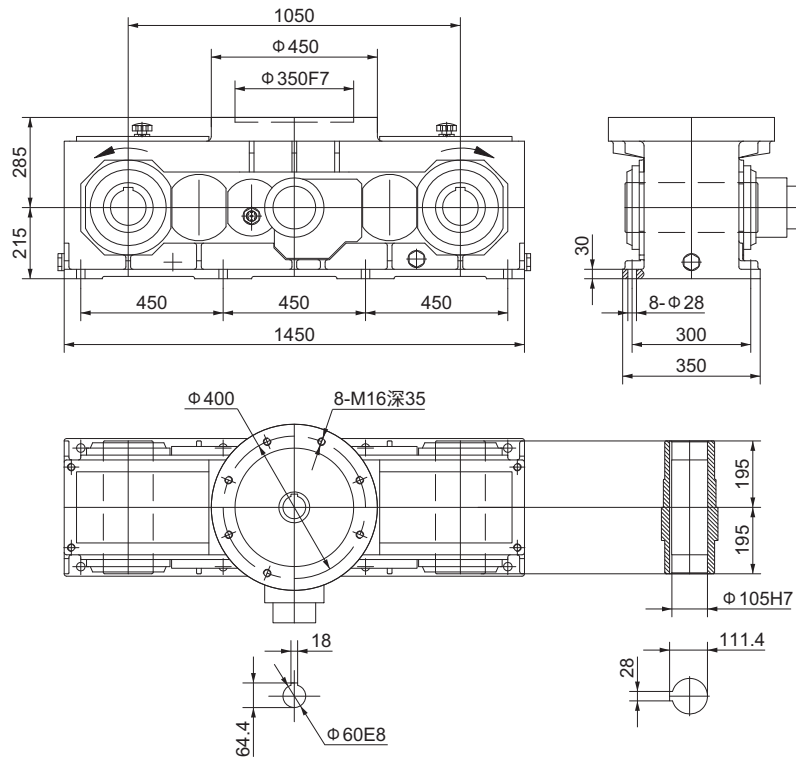

9.1 型号 / Model : THB4L1230-AM250-50

9.2 技术参数 / Technical parameters

|  |         |
|--|---------|
| 中心距 / Center distance  | 1230 mm |
| 电机 / Motor   | 55kW-4P |
| 速比 / Ratio   | 50      |
| 输出转速 / Output speed  | 30 rpm  |
| 适用于 8 立方米 - 10 立方米无重力双轴搅拌机<br>For 8 m <sup>3</sup> - 10 m <sup>3</sup> gravity-free two-axis mixer |         |

9.3 安装尺寸图 / Installation figure

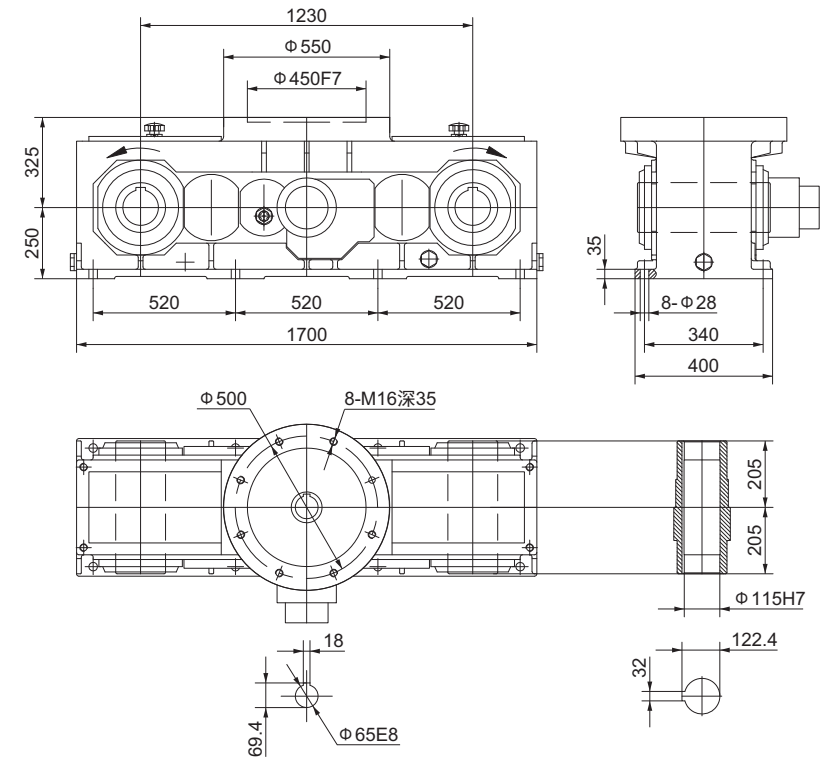



10.1 型号 / Model : THB4L1230-AM280-50

10.2 技术参数 / Technical parameters

|  |         |
|--|---------|
| 中心距 / Center distance  | 1230 mm |
| 电机 / Motor   | 75kW-4P |
| 速比 / Ratio   | 50      |
| 输出转速 / Output speed  | 30 rpm  |
| 适用于 8 立方米 - 10 立方米无重力双轴搅拌机<br>For 8 m <sup>3</sup> - 10 m <sup>3</sup> gravity-free two-axis mixer |         |

10.3 安装尺寸图 / Installation figure

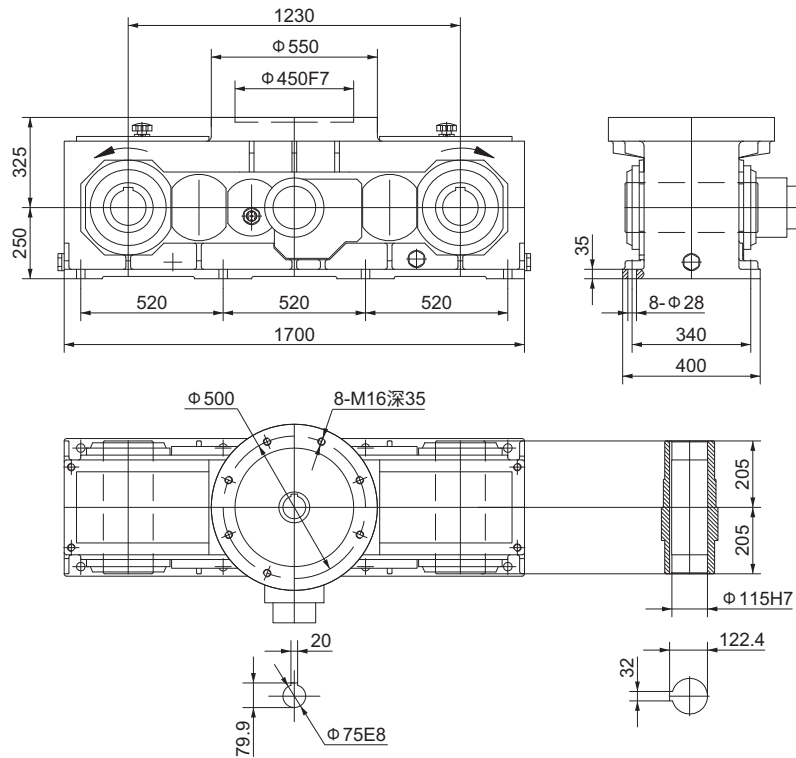

11.1 型号 / Model : THB4L1360-AM280-50

11.2 技术参数 / Technical parameters

|  |         |
|--|---------|
| 中心距 / Center distance  | 1360 mm |
| 电机 / Motor   | 90kW-4P |
| 速比 / Ratio   | 50      |
| 输出转速 / Output speed  | 30 rpm  |
| 适用于 12 立方米 - 15 立方米无重力双轴搅拌机<br>For 12 m <sup>3</sup> - 15 m <sup>3</sup> gravity-free two-axis mixer |         |

11.3 安装尺寸图 / Installation figure

