

LK

- ◆ 小体积 耐高频大纹波电流 高频低阻抗 电源专用产品
- ◆ 105℃环境下6000小时~8000小时
- ◆ 符合AEC-Q200 RoHS指令对应



■ 主要技术参数

项目	特性									
使用温度范围	≤120V.DC -55℃~+105℃ ; 160~500V.DC -40℃~+105℃									
标称电压范围	10~500V.DC									
容量允许偏差	±20% (25±2℃ 120Hz)									
漏电流(µA)	10~120WV I≤0.01CV or 3µA取大者 C:标称容量(µF) V:额定电压(V) 2分钟读数									
	160~500WV I≤0.02CV+10(µA) C:标称容量(µF) V:额定电压(V) 2分钟读数									
损耗角正切值 (25±2℃ 120Hz)	额定电压(V)	10	16	25	35	50	63	80	100	
	tg δ	0.19	0.16	0.14	0.12	0.10	0.09	0.09	0.09	
	额定电压(V)	120	160	200	250	350	400	450	500	
	tg δ	0.09	0.09	0.08	0.08	0.10	0.10	0.12	0.20	
标称容量超过1000µF者, 则每增加1000µF, 损耗角正切值增加0.02										
温度特性 (120Hz)	额定电压(V)	10	16	25	35	50	63	80	100	
	阻抗比Z(-40℃)/Z(20℃)	6	4	3	3	3	3	3	3	
	额定电压(V)	120	160	200	250	350	400	450	500	
	阻抗比Z(-40℃)/Z(20℃)	5	5	5	5	7	7	7	8	
耐久性	在105℃烘箱中, 施加含额定纹波电流的额定电压, 持续规定时间后, 置于常温16小时后测试, 测试温度25±2℃, 电容器的性能应满足如下要求									
	容量变化率	在初始值的±20%以内								
	损耗角正切值	在规定值的200%以下								
	漏电流	在规定值以下								
	负荷寿命	≤φ5~φ6.3							6000小时	
	≥φ8							8000小时		
高温储存	在105℃下, 储存1000小时, 置于常温16小时后测试, 测试温度25±2℃, 电容器的性能应满足如下要求									
	容量变化率	在初始值的±20%以内								
	损耗角正切值	在规定值的200%以下								
	漏电流	在规定值的200%以下								

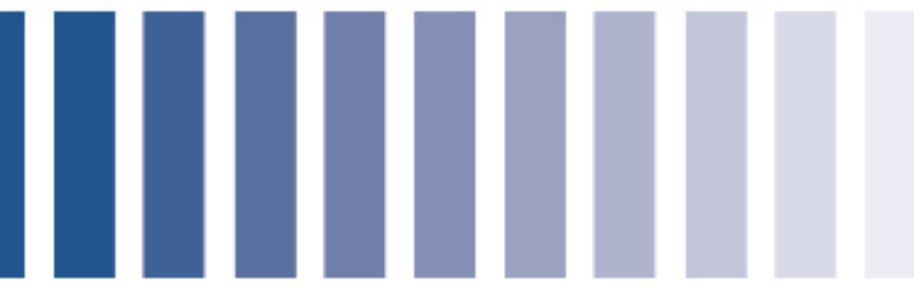

LK

■ 标准品一览表

电压(V)	10			16			25			35		
项目 容量 (μ F)	尺寸 D×L(mm)	阻抗 (Ω max/100kHz 25±2°C)	纹波电流 (mA r.m.s/ 105°C 100kHz)	尺寸 D×L(mm)	阻抗 (Ω max/100kHz 25±2°C)	纹波电流 (mA r.m.s/ 105°C 100kHz)	尺寸 D×L(mm)	阻抗 (Ω max/100kHz 25±2°C)	纹波电流 (mA r.m.s/ 105°C 100kHz)	尺寸 D×L(mm)	阻抗 (Ω max/100kHz 25±2°C)	纹波电流 (mA r.m.s/ 105°C 100kHz)
10	5×9	1.10	55	5×9	1.10	70	5×9	1.10	90	5×9	1.60	100
15	5×9	1.10	75	5×9	1.10	90	5×9	1.10	110	5×9	1.10	120
22	5×9	0.42	90	5×9	0.42	110	5×9	1.10	120	5×9	1.10	160
33	5×9	0.42	105	5×9	0.42	120	5×9	0.42	150	5×9	0.42	215
39	5×9	0.42	135	5×9	0.42	150	5×9	0.42	180	5×9	0.42	215
47	5×9	0.28	142	5×9	0.28	160	5×9	0.28	210	5×11	0.38	310
56	5×9	0.28	150	5×9	0.28	170	5×9	0.28	290	5×11	0.38	310
68	5×9	0.28	160	5×9	0.28	180	5×11	0.25	310	6.3×9	0.36	390
82	5×9	0.28	170	5×9	0.28	210	5×11	0.25	310	6.3×9	0.36	390
100	5×9	0.28	180	5×9	0.28	290	5×11	0.25	310	6.3×11	0.17	404
100										8×9	0.17	441
120	5×9	0.28	210	5×11	0.25	310	6.3×9	0.25	390	8×9	0.17	441
150	5×9	0.28	290	6.3×9	0.25	390	6.3×11	0.17	404	8×11.5	0.13	830
150							8×9	0.17	441	10×9	0.13	765
180	5×11	0.28	290	6.3×9	0.25	390	6.3×11	0.17	404	8×11.5	0.13	830
180							8×9	0.17	441	10×9	0.13	765
220	5×11	0.25	310	6.3×11	0.17	404	6.3×11	0.17	404	8×11.5	0.13	830
220				8×9	0.17	441	8×9	0.17	441	10×9	0.13	765
270	6.3×9	0.25	390	6.3×11	0.17	404	8×11.5	0.10	830	8×16	0.10	1150
270				8×9	0.17	441	10×9	0.10	765	10×12.5	0.10	1150
330	6.3×11	0.17	404	6.3×11	0.17	650	8×11.5	0.10	830	8×16	0.10	1170
330	8×9	0.17	441	8×9	0.17	765	10×9	0.10	765	10×12.5	0.10	1150
390	6.3×11	0.17	650	8×11.5	0.10	830	8×14	0.12	1150	8×20	0.0505	1350
390	8×9	0.17	765	10×9	0.10	765	10×12.5	0.10	1150	10×16	0.0505	1550
470	6.3×11	0.17	650	8×11.5	0.10	830	8×16	0.10	1170	8×20	0.0505	1350
470	8×9	0.17	765	10×9	0.10	765	10×12.5	0.10	1150	10×16	0.0505	1550
560	8×11.5	0.10	830	8×11.5	0.10	830	8×20	0.0505	1350	10×16	0.0420	1550
560	10×9	0.10	765	10×9	0.10	765	10×12.5	0.10	1150	12.5×14	0.0500	1808
680	8×11.5	0.10	830	8×16	0.10	1125	8×20	0.0505	1350	10×20	0.0420	1590
680	10×9	0.10	765	10×12.5	0.13	1150	10×16	0.0505	1550	12.5×16	0.0500	1910
820	8×11.5	0.10	830	8×20	0.0505	1350	10×16	0.0505	1550	10×20	0.0420	1590
820				10×14	0.0805	1350	12.5×14	0.0600	1808	12.5×16	0.0500	1910
1000	8×16	0.10	1125	8×20	0.0505	1350	10×20	0.0505	1808	12.5×20	0.0300	2250
1000	10×12.5	0.10	1150	10×14	0.0805	1350	12.5×14	0.0600	1808			
1200	8×16	0.10	1125	10×16	0.0505	1550	10×23	0.0500	2050	12.5×20	0.0300	2250
1200	10×14	0.0805	1350	12.5×14	0.0600	1808	12.5×16	0.0500	1910			
1500	8×20	0.0805	1350	10×20	0.0420	1590	12.5×20	0.0300	2250	12.5×25	0.0270	2620
1500	10×14	0.0805	1350	12.5×14	0.0600	1808				16×20	0.0270	2925
1800	10×20	0.0620	1590	10×20	0.0420	1590	12.5×20	0.0300	2250	12.5×35	0.0210	3215

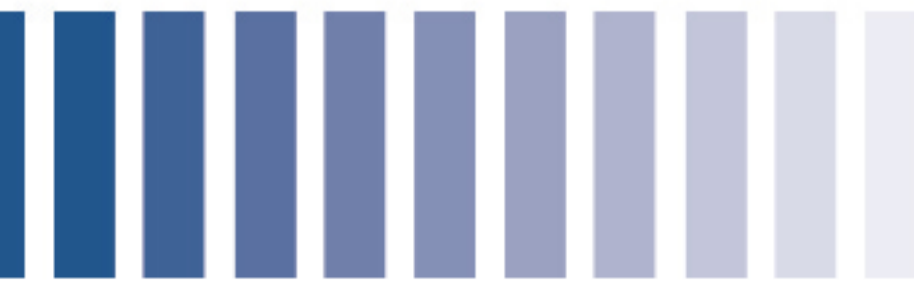

LK

■ 标准品一览表

电压(V)	10			16			25			35		
项目 容量 (μ F)	尺寸 D×L(mm)	阻抗 (Ω max/100KHz 25±2℃)	纹波电流 (mA r.m.s/ 105℃ 100KHz)	尺寸 D×L(mm)	阻抗 (Ω max/100KHz 25±2℃)	纹波电流 (mA r.m.s/ 105℃ 100KHz)	尺寸 D×L(mm)	阻抗 (Ω max/100KHz 25±2℃)	纹波电流 (mA r.m.s/ 105℃ 100KHz)	尺寸 D×L(mm)	阻抗 (Ω max/100KHz 25±2℃)	纹波电流 (mA r.m.s/ 105℃ 100KHz)
1800	12.5×14	0.0600	1808	12.5×16	0.0500	1910				16×20	0.0210	3270
2200	10×20	0.0620	1590	10×23	0.0300	2050	12.5×25	0.0270	2620	12.5×35	0.0160	3215
2200	12.5×14	0.0600	1808	12.5×20	0.0300	2250				16×25	0.0160	3270
2700	10×20	0.0620	1590	12.5×20	0.0300	2250	12.5×30	0.0250	3110	16×31.5	0.0140	3500
2700	12.5×16	0.0500	1910							18×25	0.0270	3600
3300	12.5×20	0.0300	2250	12.5×25	0.0268	2620	12.5×35	0.0250	3215	16×31.5	0.0123	3500
3300							16×25	0.0250	3270	18×25	0.0135	3600
3900	12.5×20	0.0300	2250	12.5×30	0.0255	3110	16×31.5	0.0200	3500	16×35.5	0.0100	3610
3900				16×20	0.0268	2925	18×25	0.0135	3300	18×25	0.0135	3600
4700	12.5×25	0.0270	2620	12.5×30	0.0255	3110	18×25	0.0135	3600	16×40	0.0100	3680
4700				16×25	0.0246	3270				18×35.5	0.0100	3680
5600	12.5×25	0.0270	2620	12.5×35	0.0246	3215	18×31.5	0.0120	3610			
5600				16×25	0.0246	3270						
6800	12.5×30	0.0155	3110	16×31.5	0.0213	3500	18×35.5	0.0110	3680			
6800	16×25	0.0146	3270	18×25	0.0235	3600						
8200	12.5×40	0.0123	3500	16×35.5	0.0220	3610	18×40	0.0100	3735			
8200	16×25	0.0146	3270	18×31.5	0.0220	3610						
10000	16×31.5	0.0123	3500	18×35.5	0.0210	3680						
10000	18×25	0.0135	3600									

电压(V)	50			63			80			100		
项目 容量 (μ F)	尺寸 D×L(mm)	阻抗 (Ω max/100KHz 25±2℃)	纹波电流 (mA r.m.s/ 105℃ 100KHz)	尺寸 D×L(mm)	阻抗 (Ω max/100KHz 25±2℃)	纹波电流 (mA r.m.s/ 105℃ 100KHz)	尺寸 D×L(mm)	阻抗 (Ω max/100KHz 25±2℃)	纹波电流 (mA r.m.s/ 105℃ 100KHz)	尺寸 D×L(mm)	阻抗 (Ω max/100KHz 25±2℃)	纹波电流 (mA r.m.s/ 105℃ 100KHz)
0.47	5×9	5.50	20	5×9	3.00	22	5×9	3.00	23	5×9	5.00	23
1.0	5×9	5.50	30	5×9	3.00	33	5×9	3.00	34	5×9	3.00	34
1.8	5×9	5.50	36	5×9	3.00	40	5×9	3.00	42	5×9	3.00	42
2.2	5×9	1.60	38	5×9	3.00	44	5×9	3.00	46	5×9	3.00	46
2.7	5×9	1.60	46	5×9	3.00	51	5×9	1.50	54	5×9	3.00	54
3.3	5×9	1.60	53	5×9	3.00	58	5×9	1.50	61	5×9	1.50	61
3.9	5×9	1.60	70	5×9	3.00	77	5×9	1.50	80	5×9	1.50	80
4.7	5×9	1.60	88	5×9	3.00	97	5×9	1.50	100	5×9	1.50	100
5.6	5×9	1.60	90	5×9	1.50	99	5×9	1.50	105	5×11	1.50	105
6.8	5×9	1.60	93	5×9	1.50	102	5×9	1.50	110	5×11	1.50	110
8.2	5×9	1.60	97	5×9	1.50	108	5×9	1.50	125	5×11	1.50	125
10	5×9	1.60	100	5×9	1.50	110	5×9	1.50	135	5×11	1.50	135
12	5×9	1.60	110	5×9	1.50	120	5×11	1.50	150	6.3×9	1.00	216

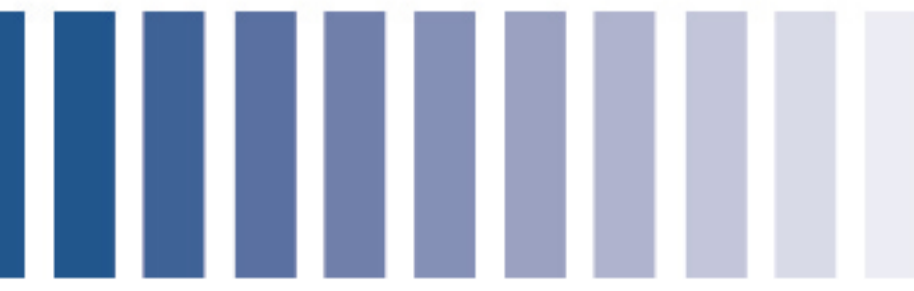

LK

■ 标准品一览表

电压(V)	50			63			80			100		
项目 容量 (μ F)	尺寸 D×L(mm)	阻抗 (Ω max/100KHz 25±2℃)	纹波电流 (mA r.m.s/ 105℃ 100KHz)	尺寸 D×L(mm)	阻抗 (Ω max/100KHz 25±2℃)	纹波电流 (mA r.m.s/ 105℃ 100KHz)	尺寸 D×L(mm)	阻抗 (Ω max/100KHz 25±2℃)	纹波电流 (mA r.m.s/ 105℃ 100KHz)	尺寸 D×L(mm)	阻抗 (Ω max/100KHz 25±2℃)	纹波电流 (mA r.m.s/ 105℃ 100KHz)
15	5×9	1.60	120	5×9	1.50	145	5×11	1.50	150	6.3×9	1.00	216
18	5×9	1.40	130	5×9	1.00	155	6.3×9	1.00	216	6.3×11	0.64	240
18										8×9	0.64	216
22	5×9	1.40	145	5×11	1.00	160	6.3×9	1.00	216	6.3×11	0.64	240
22										8×9	0.64	216
27	5×11	0.38	215	6.3×9	0.60	225	6.3×11	0.64	240	8×9	0.64	369
27							8×9	0.64	260			
33	5×11	0.38	215	6.3×9	0.60	225	6.3×11	0.64	240	8×11.5	0.41	410
33							8×9	0.64	260	10×9	0.41	369
39	6.3×9	0.38	315	6.3×9	0.40	250	8×9	0.64	260	8×11.5	0.41	410
39										10×9	0.41	369
47	6.3×9	0.36	350	6.3×11	0.40	250	8×11.5	0.41	410	8×16	0.29	510
47				8×9	0.50	260	10×9	0.41	450	10×12.5	0.29	510
56	6.3×11	0.36	350	8×9	0.50	350	8×11.5	0.41	410	8×16	0.29	510
56	8×9	0.25	450				10×9	0.41	450	10×12.5	0.26	565
68	6.3×11	0.36	350	8×11.5	0.25	480	8×11.5	0.41	410	8×20	0.22	660
68	8×9	0.25	450	10×9	0.25	490	10×9	0.41	450	10×14	0.22	660
82	8×9	0.25	585	8×11.5	0.25	480	8×16	0.29	510	8×20	0.22	660
82				10×9	0.25	490	10×12.5	0.29	565	10×16	0.20	710
100	8×9	0.25	585	8×14	0.25	550	8×16	0.29	510	10×16	0.20	710
100				10×9	0.25	500	10×12.5	0.26	565	12.5×14	0.18	833
120	8×11.5	0.16	630	8×16	0.19	620	8×20	0.22	660	10×20	0.14	950
120	10×9	0.16	650	10×12.5	0.18	630	10×14	0.20	660	12.5×14	0.18	833
150	8×14	0.12	760	8×20	0.14	775	10×16	0.20	710	10×20	0.15	950
150	10×9	0.12	650	10×14	0.14	810	12.5×14	0.18	833	12.5×16	0.15	880
180	8×16	0.12	860	8×20	0.14	775	10×20	0.14	950	12.5×20	0.0959	1290
180	10×12.5	0.12	875	10×16	0.14	900	12.5×14	0.18	833			
220	8×16	0.12	860	10×16	0.14	900	10×20	0.14	950	12.5×20	0.0959	1290
220	10×12.5	0.12	875				12.5×16	0.18	1020			
270	8×20	0.0768	1080	10×20	0.0877	1080	12.5×20	0.0959	1290	12.5×25	0.0673	1460
270	10×16	0.0768	1250	12.5×14	0.0920	1022						
330	10×16	0.0768	1250	10×20	0.0877	1080	12.5×20	0.0959	1290	12.5×30	0.0571	1760
330	12.5×14	0.0810	1022	12.5×16	0.0920	1080	12.5*16	0.15	1020	16×20	0.0653	1560
390	10×20	0.0695	1430	12.5×20	0.0673	1415	12.5×25	0.0673	1460	12.5×35	0.0520	1930
390	12.5×14	0.0810	1022	12.5×20	0.0673	1415	12.5×25	0.0673	1460	16×25	0.0480	1990
470	10×20	0.0695	1430				16×20	0.0653	1560	16×25	0.0480	1990
470	12.5×16	0.0675	1080	12.5×25	0.0479	1800	12.5×30	0.0571	1760	18×20	0.0465	1990
560	12.5×16	0.0675	1598				16×25	0.0480	1990	16×31.5	0.0368	2160
560										18×25	0.0427	2050

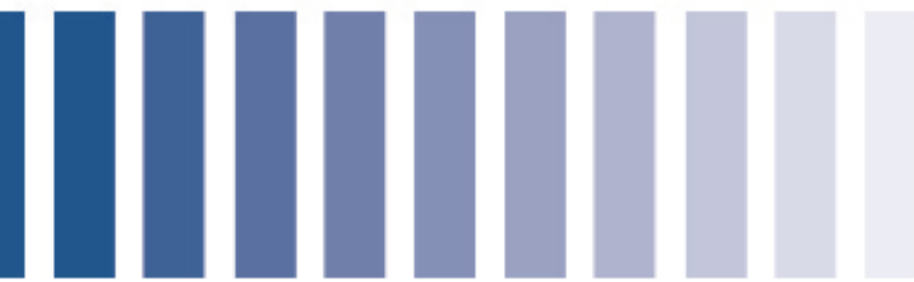

LK

■ 标准品一览表

电压(V)	50			63			80			100		
项目 容量 (μF)	尺寸 D×L(mm)	阻抗 ($\Omega_{max/100KHz}$ 25±2℃)	纹波电流 (mA r.m.s/ 105℃ 100KHz)	尺寸 D×L(mm)	阻抗 ($\Omega_{max/100KHz}$ 25±2℃)	纹波电流 (mA r.m.s/ 105℃ 100KHz)	尺寸 D×L(mm)	阻抗 ($\Omega_{max/100KHz}$ 25±2℃)	纹波电流 (mA r.m.s/ 105℃ 100KHz)	尺寸 D×L(mm)	阻抗 ($\Omega_{max/100KHz}$ 25±2℃)	纹波电流 (mA r.m.s/ 105℃ 100KHz)
680	12.5×20	0.0600	1850	12.5×30	0.0410	2370	12.5×35	0.0520	1930	16×35.5	0.0326	2340
680				16×20	0.0482	1890	16×25	0.0480	1990	18×31.5	0.0346	2230
820	12.5×25	0.0625	2170	12.5×35	0.0367	2360	16×31.5	0.0368	2160	16×40	0.0305	2580
820				16×25	0.0385	2460	18×25	0.0427	2050	18×35.5	0.0305	3160
1000	12.5×30	0.0580	2580	16×25	0.0385	2460	16×35.5	0.0326	2340	18×40	0.0305	3160
1000	16×20	0.0580	2460	18×20	0.0426	2550	18×31.5	0.0346	2230			
1200	12.5×30	0.0580	2580	16×31.5	0.0350	2695	16×40	0.0305	2580			
1200	16×25	0.0455	2710	18×25	0.0350	2520	18×31.5	0.0246	2970			
1500	12.5×40	0.0211	2745	16×31.5	0.0350	2695	18×35.5	0.0246	3160			
1500	16×25	0.0240	2710	18×31.5	0.0350	2970						
1800	16×31.5	0.0265	2960	16×40	0.0350	3215	18×40	0.0204	3160			
1800	18×25	0.0347	2760	18×31.5	0.0350	2970						
2200	18×31.5	0.0286	2970	18×35.5	0.0350	3215						
2700	18×35.5	0.0224	3215	18×40	0.0350	3310						
3300	18×40	0.0204	3410									

电压(V)	120			160			200			250		
项目 容量 (μF)	尺寸 D×L(mm)	阻抗 ($\Omega_{max/100KHz}$ 25±2℃)	纹波电流 (mA r.m.s/ 105℃ 100KHz)	尺寸 D×L(mm)	阻抗 ($\Omega_{max/100KHz}$ 25±2℃)	纹波电流 (mA r.m.s/ 105℃ 100KHz)	尺寸 D×L(mm)	阻抗 ($\Omega_{max/100KHz}$ 25±2℃)	纹波电流 (mA r.m.s/ 105℃ 100KHz)	尺寸 D×L(mm)	阻抗 ($\Omega_{max/100KHz}$ 25±2℃)	纹波电流 (mA r.m.s/ 105℃ 100KHz)
0.47	5×9	6.60	23									
1.0	5×9	6.60	34	5×11	40.00	50	5×11	40.00	50	6.3×9	30.00	95
1.2	5×9	6.60	34	5×11	40.00	55	5×11	40.00	55	6.3×9	30.00	95
1.5	5×9	6.60	42	5×11	40.00	60	5×11	40.00	60	6.3×9	30.00	95
1.8	5×9	6.60	42	5×11	40.00	65	5×11	40.00	65	6.3×9	30.00	95
2.2	5×9	1.80	46	5×11	40.00	75	5×11	40.00	75	6.3×9	30.00	104
2.7	5×9	1.80	54	5×11	40.00	80	5×11	40.00	80	6.3×9	30.00	113
3.3	5×9	1.80	61	5×11	40.00	90	6.3×9	30.00	95	6.3×9	30.00	113
3.9	5×9	1.80	80	5×11	40.00	90	6.3×9	30.00	104	6.3×9	15.00	113
4.7	5×9	1.80	100	6.3×9	25.00	104	6.3×11	15.00	115	6.3×11	15.00	125
4.7							8×9	15.00	135	8×9	15.00	135
5.6	5×11	1.80	105	6.3×9	25.00	104	6.3×11	15.00	115	8×9	15.00	135
5.6							8×9	15.00	135			
6.8	5×11	1.60	110	6.3×9	25.00	122	8×9	15.00	135	8×9	15.00	135
8.2	5×11	1.60	125	6.3×11	22.00	125	8×9	15.00	135	8×11.5	15.00	150
8.2				8×9	22.00	130				10×9	15.00	150
10	6.3×9	1.21	135	8×9	22.00	130	8×11.5	15.00	150	8×11.5	15.00	150

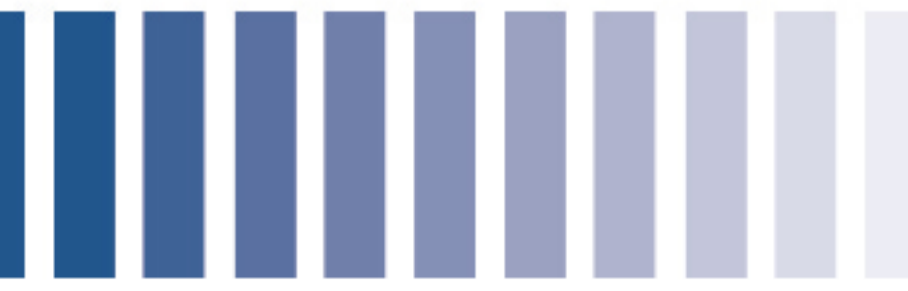

LK

■ 标准品一览表

电压(V)	120			160			200			250		
项目 容量 (μ F)	尺寸 D×L(mm)	阻抗 (Ω max/100kHz 25±2℃)	纹波电流 (mA r.m.s/ 105℃ 100kHz)	尺寸 D×L(mm)	阻抗 (Ω max/100kHz 25±2℃)	纹波电流 (mA r.m.s/ 105℃ 100kHz)	尺寸 D×L(mm)	阻抗 (Ω max/100kHz 25±2℃)	纹波电流 (mA r.m.s/ 105℃ 100kHz)	尺寸 D×L(mm)	阻抗 (Ω max/100kHz 25±2℃)	纹波电流 (mA r.m.s/ 105℃ 100kHz)
10							10×9	15.00	150	10×9	15.00	150
12	6.3×9	1.21	163	8×11.5	20.00	135	8×14	12.00	220	8×14	12.00	220
15	6.3×11	0.83	195	8×11.5	16.00	135	8×16	8.92	250	8×16	8.92	250
15	8×9	0.83	195	10×9	16.00	140	10×12.5	8.92	260	10×12.5	8.92	250
18	8×9	0.83	215	8×11.5	16.00	135	8×20	6.80	315	8×20	6.80	315
18				10×9	16.00	140	10×14	6.80	290	10×14	6.80	290
22	8×9	0.83	215	8×16	8.92	250	8×20	6.80	315	8×20	6.80	315
22				10×12.5	8.92	250	10×14	6.80	290	10×14	6.80	290
27	8×11.5	0.64	369									
33	8×11.5	0.50	369	8×20	6.80	315	10×20	6.60	575	10×20	6.60	575
33	10×9	0.50	369	10×12.5	6.80	450	12.5×14	6.60	670	12.5×14	6.00	650
39	8×14	0.41	410									
39	10×12.5	0.41	410									
47	8×16	0.32	451	10×16	6.60	580	12.5×20	4.65	870	12.5×20	4.65	870
47	10×12.5	0.32	451	12.5×14	6.60	650						
56	8×20	0.29	510	10×20	6.60	600	12.5×20	4.65	870	12.5×20	4.65	870
56	10×14	0.29	565	12.5×14	6.60	670						
68	8×23	0.22	660	10×23	4.65	670	12.5×25	4.31	1150	12.5×25	4.31	1150
68	10×16	0.22	660	12.5×16	4.65	770	16×20	4.31	1200	16×20	4.31	1200
82	10×16	0.22	660	10×23	4.65	770	12.5×25	4.31	1150	12.5×25	4.31	1150
82	12.5×14	0.20	710	12.5×20	4.65	1040	16×20	4.31	1200	16×20	4.31	1200
100	10×20	0.20	710	12.5×20	4.65	1040	12.5×25	4.31	1150	12.5×30	3.35	1260
100	12.5×16	0.18	833				16×20	4.31	1200	16×25	3.05	1350
120	10×23	0.18	850	12.5×25	4.09	1260	12.5×30	3.05	1440	16×25	3.05	1350
120	12.5×16	0.18	833	16×20	4.09	1260	16×25	3.05	1670			
150	12.5×20	0.15	950	12.5×30	4.09	1600	16×25	3.05	1670	16×31.5	2.71	1780
150				16×25	3.92	1670				18×25	2.71	1780
180	12.5×25	0.11	1290	12.5×35	3.01	1720	16×35.5	2.10	2025	16×35.5	2.10	2025
180				16×25	3.92	1670	18×25	2.71	2025	18×31.5	2.10	2025
220	16×20	0.11	1290	16×31.5	2.71	2160	18×31.5	2.10	2200	18×35.5	1.04	2365
220				18×25	2.71	2090						
270	12.5×30	0.0859	1460									
270	16×20	0.0859	1460									
330	16×25	0.0671	1760	18×31.5	1.25	2400						
330	18×20	0.0671	1560	18×35.5	1.15	2850						
390	16×31.5	0.0520	1930									
390	18×25	0.0520	1990									
470	16×31.5	0.0480	1990									
470	18×25	0.0480	1990									

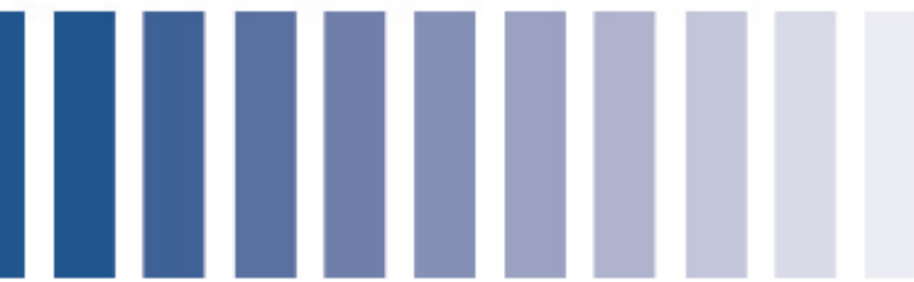

LK

■ 标准品一览表

电压(V)	120			160			200			250		
项目 容量 (μ F)	尺寸 D×L(mm)	阻抗 (Ω max/100KHz 25±2℃)	纹波电流 (mA r.m.s/ 105℃ 100KHz)	尺寸 D×L(mm)	阻抗 (Ω max/100KHz 25±2℃)	纹波电流 (mA r.m.s/ 105℃ 100KHz)	尺寸 D×L(mm)	阻抗 (Ω max/100KHz 25±2℃)	纹波电流 (mA r.m.s/ 105℃ 100KHz)	尺寸 D×L(mm)	阻抗 (Ω max/100KHz 25±2℃)	纹波电流 (mA r.m.s/ 105℃ 100KHz)
560	16×35.5	0.0368	2160									
560	18×31.5	0.0368	2050									
680	18×35.5	0.0326	2340									

电压(V)	350			400			450			500		
项目 容量 (μ F)	尺寸 D×L(mm)	阻抗 (Ω max/100KHz 25±2℃)	纹波电流 (mA r.m.s/ 105℃ 100KHz)	尺寸 D×L(mm)	阻抗 (Ω max/100KHz 25±2℃)	纹波电流 (mA r.m.s/ 105℃ 100KHz)	尺寸 D×L(mm)	阻抗 (Ω max/100KHz 25±2℃)	纹波电流 (mA r.m.s/ 105℃ 100KHz)	尺寸 D×L(mm)	阻抗 (Ω max/100KHz 25±2℃)	纹波电流 (mA r.m.s/ 105℃ 100KHz)
1.0	6.3×9	38.00	68	6.3×9	58.00	68	6.3×9	58.00	77	6.3×11	52.00	40
1.2	6.3×9	38.00	95	6.3×9	38.00	77	6.3×9	55.00	77	6.3×11	52.00	40
1.5	6.3×9	38.00	95	6.3×9	38.00	77	6.3×9	55.00	85	6.3×11	52.00	40
1.8	6.3×9	38.00	104	6.3×9	33.00	90	6.3×11	55.00	90	8×9	48.00	72
1.8							8×9	45.00	90			
2.2	6.3×9	33.00	120	6.3×9	33.00	90	8×9	45.00	90	8×11.5	45.00	72
2.7	6.3×11	33.00	120	6.3×11	33.00	110	8×9	45.00	90	8×11.5	45.00	76
2.7	8×9	27.00	130	8×9	27.00	117						
3.3	6.3×11	33.00	120	6.3×12	33.00	110	8×11.5	25.50	130	8×11.5	45.00	76
3.3	8×9	27.00	130	8×9	27.00	117	10×9	25.50	130			
3.9	6.3×12	33.00	120	6.3×12	33.00	110	8×11.5	25.50	130	8×14	35.00	92
3.9	8×9	27.00	130	8×9	27.00	117	10×9	25.50	130			
4.7	6.3×12	33.00	120	6.3×12	33.00	120	8×11.5	25.50	130	8×16	29.00	102
4.7	8×9	27.00	130	8×11.5	27.00	135	10×9	18.00	130	10×12.5	22.50	102
5.6	8×11.5	21.00	135	8×14	18.00	180	8×16	13.50	135	10×14	18.00	117
5.6	10×9	21.00	150	10×9	18.00	180	10×12.5	13.50	180			
6.8	8×11.5	21.00	135	8×16	13.50	180	8×20	9.50	200	10×14	18.00	117
6.8	10×9	21.00	150	10×12.5	13.50	180	10×12.5	13.50	180			
8.2	8×16	13.50	180	8×16	13.50	180	8×20	9.50	200	10×16	15.00	152
8.2	10×12.5	13.50	190	10×12.5	13.50	180	10×14	12.00	205			
10	8×16	13.50	180	8×20	9.50	250	10×16	9.50	205	10×20	11.00	216
10	10×12.5	13.50	220	10×14	9.50	250	12.5×14	9.20	315	12.5×14	10.00	234
12	10×14	11.00	240	10×16	9.00	280	10×20	8.15	300	12.5×16	9.50	240
15	10×16	9.50	280	10×20	8.15	310	10×20	8.15	300	12.5×16	9.00	240
15	12.5×14	8.15	530	12.5×14	8.15	310	12.5×16	8.15	410			
18	10×20	8.15	550	10×20	8.15	310	12.5×20	8.15	410	12.5×20	8.00	288
18	12.5×14	8.15	530	12.5×16	8.15	330						
22	12.5×16	8.15	600	12.5×20	8.15	500	12.5×20	8.15	410	12.5×25	7.00	423
33	12.5×20	8.15	865	12.5×25	5.14	670	12.5×25	6.50	650	12.5×30	6.50	508

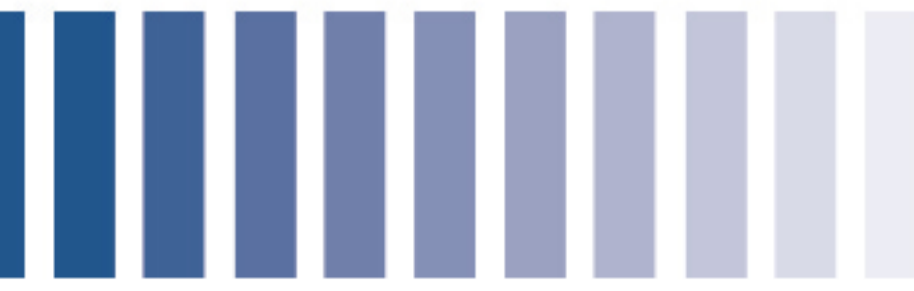

LK

■ 标准品一览表

电压(V)	350			400			450			500		
项目 容量 (μF)	尺寸 D×L(mm)	阻抗 (Ω max/100kHz 25±2℃)	纹波电流 (mA r.m.s/ 105℃ 100kHz)	尺寸 D×L(mm)	阻抗 (Ω max/100kHz 25±2℃)	纹波电流 (mA r.m.s/ 105℃ 100kHz)	尺寸 D×L(mm)	阻抗 (Ω max/100kHz 25±2℃)	纹波电流 (mA r.m.s/ 105℃ 100kHz)	尺寸 D×L(mm)	阻抗 (Ω max/100kHz 25±2℃)	纹波电流 (mA r.m.s/ 105℃ 100kHz)
33				16×20	4.54	670	16×20	4.14	650			
47	12.5×25	4.14	960	12.5×30	4.14	1035	12.5×35	3.50	950	12.5×35	5.50	630
47	16×20	4.14	1000	16×25	4.14	1035	16×25	3.50	950	16×25	3.50	630
56	12.5×25	4.14	960	16×25	4.14	1035	16×31.5	3.50	1100	16×31.5	2.50	648
56	16×20	4.14	1000	18×20	4.14	1280	18×25	3.50	1060			
68	16×25	4.05	1150	16×31.5	3.50	1315	16×35.5	3.05	1240	16×35.5	2.30	756
68	18×20	3.50	1330	18×25	3.50	1330	18×31.5	3.05	1290	18×31.5	2.30	756
82	16×31.5	3.50	1400	16×35.5	3.05	1720	16×40	2.95	1510	18×35.5	1.80	990
82	18×25	3.50	1600	18×31.5	3.05	1720	18×31.5	3.05	1290			
100	16×31.5	3.50	2010	18×31.5	3.05	2010	18×35.5	2.75	1490	18×40	1.50	1020
100	18×25	3.50	2010									
120	16×35.5	3.05	2080	18×35.5	2.05	2250	18×40	2.05	1740			
120	18×31.5	3.05	2010									
150	18×35.5	2.05	2450	18×40	2.00	2500	18×45	2.00	1950			

■ 产品尺寸图 (单位: mm)

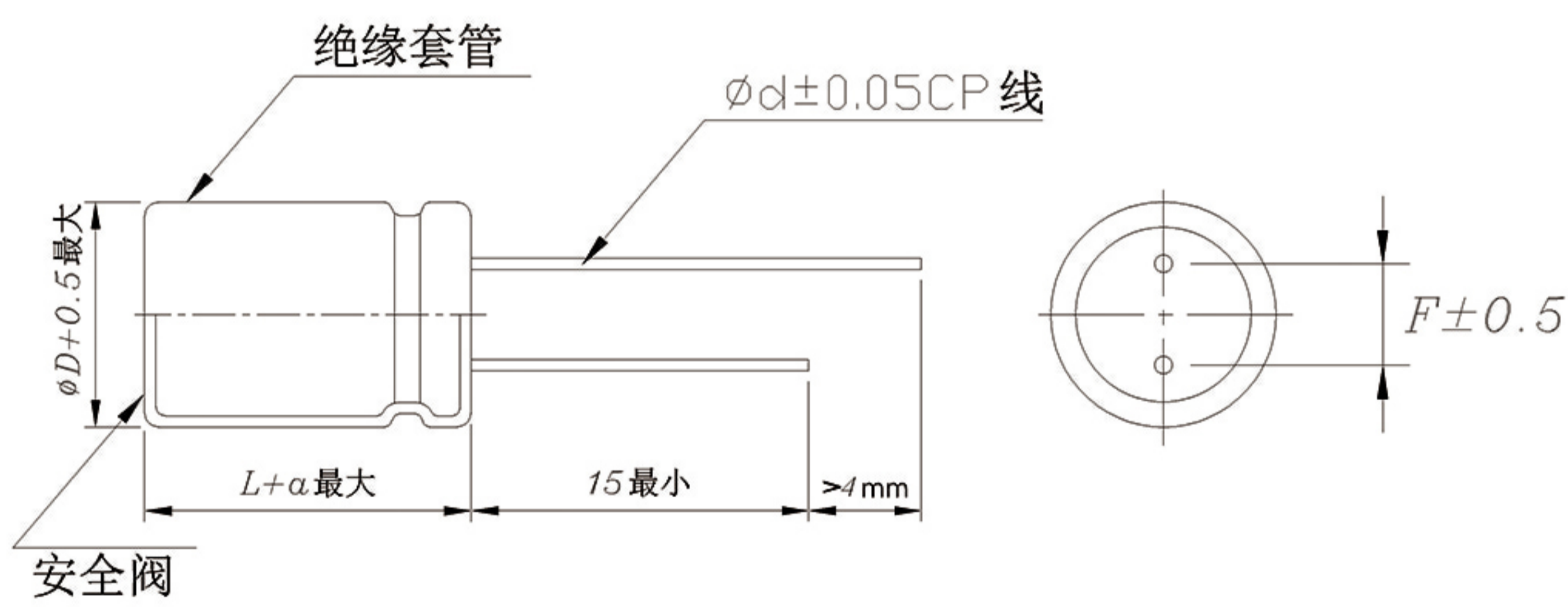

备注: $\geq \phi 6.3$ 产品有安全阀

L=9	a=1.0
L≤16	a=1.5
L>16	a=2.0

D	5	6.3	8	10	12.5	16	18
d	0.5	0.5	0.6	0.6	0.6	0.8	0.8
F	2.0	2.5	3.5	5.0	5.0	7.5	7.5

■ 纹波电流补偿系数

① 频率修正系数

频率	50	120	1K	10K~50K	100K
修正因子	0.40	0.50	0.80	0.90	1.00

② 温度修正系数

环境温度(℃)	50℃	70℃	85℃	105℃
修正因子	2.1	1.8	1.4	1.0