

包封金属化聚丙烯膜电容器 (MPP/CBB21) 规格书

特点

- 电容器容量范围从 0.01uF 到 3.3uF。
- 工作温度：-40℃~105℃
- 储存温度： 15℃~35℃
- 损耗少，内部温升小。
- 金属化聚丙烯膜组成，无感结构。
- 承受高脉冲，大电流，耐高频 100KHz。
- 容量变化小，负温度系数。
- 环氧树脂包封。

用途

- 广泛应用于高频、直流、交流和脉冲电路中。
- 广泛用于大电流场合。

料号编码原则

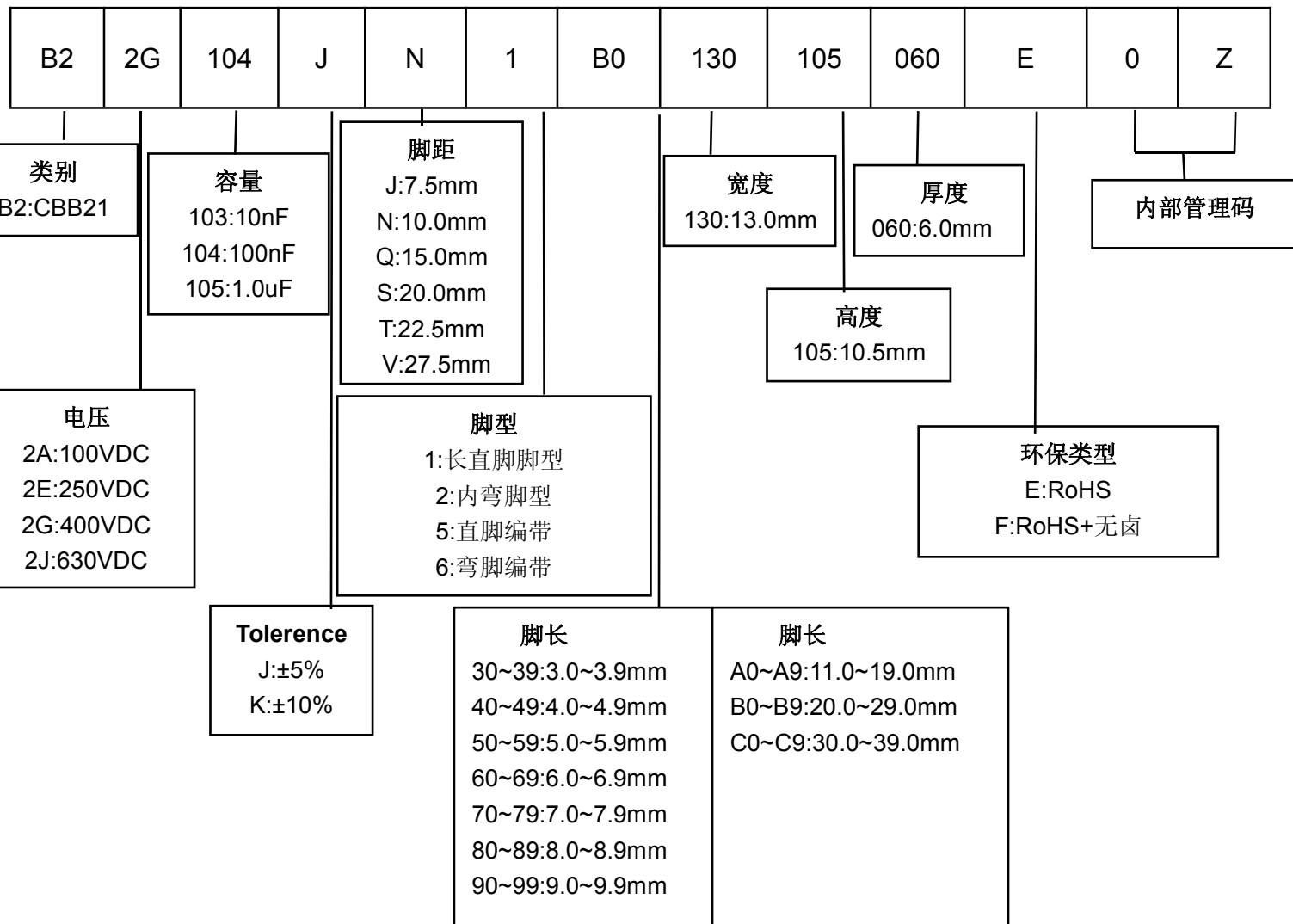

技术要求

气候类别	40/100/56
额定电压	100VDC、250VDC、 400VDC、630VDC、
损耗角正切	≤0.1%(1KHz、1.0Vrms、20℃)
耐电压	1.6U _R (5s)
绝缘电阻	C≤0.33uF, IR≥50000MΩ C>0.33uF, IR≥15000S (AT 100VDC、60SEC、20℃)

外形尺寸 (mm)



容量(uF)	电压	尺寸(mm)				
		W Max	H Max	T Max	P±1.0	d±0.05
0.01	100VDC	10.0	9.0	5.0	7.5	0.6
	250VDC	10.0	9.0	5.0	7.5	0.6
	400VDC	13.0	9.0	5.5	10.0	0.6
	630VDC	13.0	9.0	5.5	10.0	0.6
0.015	100VDC	10.0	9.0	5.5	7.5	0.6
	250VDC	10.0	9.0	5.5	7.5	0.6
	400VDC	13.0	9.0	5.5	10.0	0.6
	630VDC	13.0	11.0	6.0	10.0	0.6
0.018	100VDC	10.0	9.5	5.5	7.5	0.6
	250VDC	10.0	9.5	5.5	7.5	0.6
	400VDC	13.0	9.0	5.5	10.0	0.6
	630VDC	13.0	9.0	5.5	10.0	0.6
0.022	100VDC	10.0	8.5	5.5	7.5	0.6
	250VDC	10.0	8.5	5.5	7.5	0.6
	400VDC	13.0	9.0	5.5	10.0	0.6
	630VDC	13.0	9.0	5.5	10.0	0.6
0.027	100VDC	10.0	9.5	5.5	7.5	0.6
	250VDC	10.0	9.5	5.5	7.5	0.6
	400VDC	13.0	9.0	5.5	10.0	0.6
	630VDC	13.0	9.0	5.5	10.0	0.6
0.033	100VDC	10.0	9.5	6.0	7.5	0.6
	250VDC	10.0	9.5	6.0	7.5	0.6
	400VDC	13.0	10.0	6.0	10.0	0.6
	630VDC	13.0	10.0	6.0	10.0	0.6

容量(μF)	电压	尺寸(mm)				
		W Max	H Max	T Max	P±1.0	d±0.05
0.047	100VDC	10.0	9.5	5.5	7.5	0.6
	250VDC	10.0	9.5	5.5	7.5	0.6
	400VDC	13.0	9.0	5.5	10.0	0.6
	630VDC	13.0	10.5	6.5	10.0	0.6
0.056	100VDC	10.0	9.0	5.5	7.5	0.6
	250VDC	10.0	9.0	5.5	7.5	0.6
	400VDC	13.0	8.5	5.5	10.0	0.6
	630VDC	13.0	11.5	7.5	10.0	0.6
0.068	100VDC	10.0	9.5	6.0	7.5	0.6
	250VDC	10.0	9.5	6.0	7.5	0.6
	400VDC	13.0	9.5	6.0	10.0	0.6
	630VDC	18.0	11.0	6.0	15.0	0.8
0.1	100VDC	10.0	10.0	6.5	7.5	0.6
	250VDC	10.0	10.0	6.5	7.5	0.6
	400VDC	13.0	10.5	6.0	10.0	0.6
	630VDC	18.0	10.5	7.0	15.0	0.8
0.15	100VDC	13.0	10.5	6.5	10.0	0.6
	250VDC	13.0	10.5	6.5	10.0	0.6
	400VDC	13.0	11.5	7.0	10.0	0.6
	630VDC	18.0	13.0	7.5	15.0	0.8
0.22	100VDC	13.0	11.0	7.0	10.0	0.6
	250VDC	13.0	11.0	7.0	10.0	0.6
	400VDC	18.0	13.0	7.5	15.0	0.8
	630VDC	18.0	14.5	8.5	15.0	0.8
0.33	100VDC	13.0	12.5	8.5	10.0	0.6
	250VDC	13.0	12.5	8.5	10.0	0.6
	400VDC	18.0	14.5	7.0	15.0	0.8
	630VDC	18.0	17.5	10.0	15.0	0.8
0.47	100VDC	18.0	12.5	7.0	15.0	0.8
	250VDC	18.0	12.5	7.0	15.0	0.8
	400VDC	18.0	15.5	8.5	15.0	0.8
	630VDC	23.0	18.5	11.0	20.0	0.8
0.68	100VDC	18.0	14.5	8.0	15.0	0.8
	250VDC	18.0	14.5	8.0	15.0	0.8
	400VDC	18.0	17.0	10.0	15.0	0.8
	630VDC	25.0	19.5	10.5	22.5	0.8

容量(uF)	电压	尺寸(mm)				
		W Max	H Max	T Max	P±1.0	d±0.05
1.0	100VDC	18.0	16.5	10.0	15.0	0.8
	250VDC	18.0	16.5	10.0	15.0	0.8
	400VDC	23.0	17.5	9.5	20.0	0.8
	630VDC	31.0	21.0	12.5	27.5	0.8
1.5	100VDC	23.0	17.5	9.5	20.0	0.8
	250VDC	23.0	17.5	9.5	20.0	0.8
	400VDC	31.0	17.5	9.0	27.5	0.8
	630VDC	31.0	24.5	14.5	27.5	0.8
2.0	100VDC	23.0	19.5	10.5	20.0	0.8
	250VDC	23.0	19.5	10.5	20.0	0.8
	400VDC	31.0	19.5	10.5	27.5	0.8
2.2	100VDC	23.0	19.5	11.5	20.0	0.8
	250VDC	23.0	19.5	11.5	20.0	0.8
	400VDC	31.0	20.0	11.5	27.5	0.8
3.0	100VDC	31.0	19.5	11.0	27.5	0.8
	250VDC	31.0	19.5	11.0	27.5	0.8
	400VDC	31.0	22.5	13.5	27.5	0.8
3.3	100VDC	31.0	20.0	11.5	27.5	0.8
	250VDC	31.0	20.0	11.5	27.5	0.8
	400VDC	31.0	24.0	14.5	27.5	0.8

脚型、脚长说明

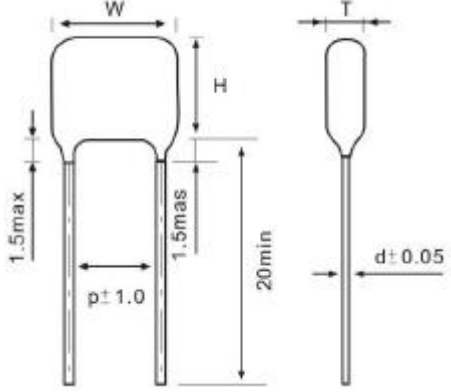
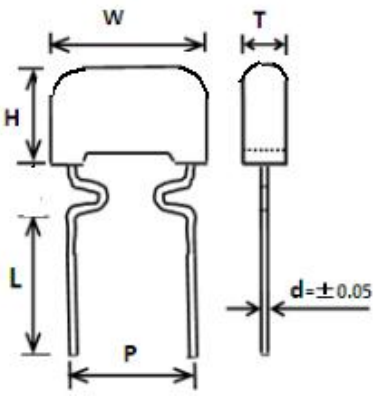
脚型	图示	脚长 L (mm)
长直脚脚型		① $[2.5 \leq L < 6.0] + / - 0.5$; ② $[6.0 \leq L \leq 10] + / - 1.0$
内弯脚型		① $[2.5 \leq L < 6.0] + / - 0.5$; ② $[6.0 \leq L \leq 10] + / - 1.0$

编带尺寸 (mm)

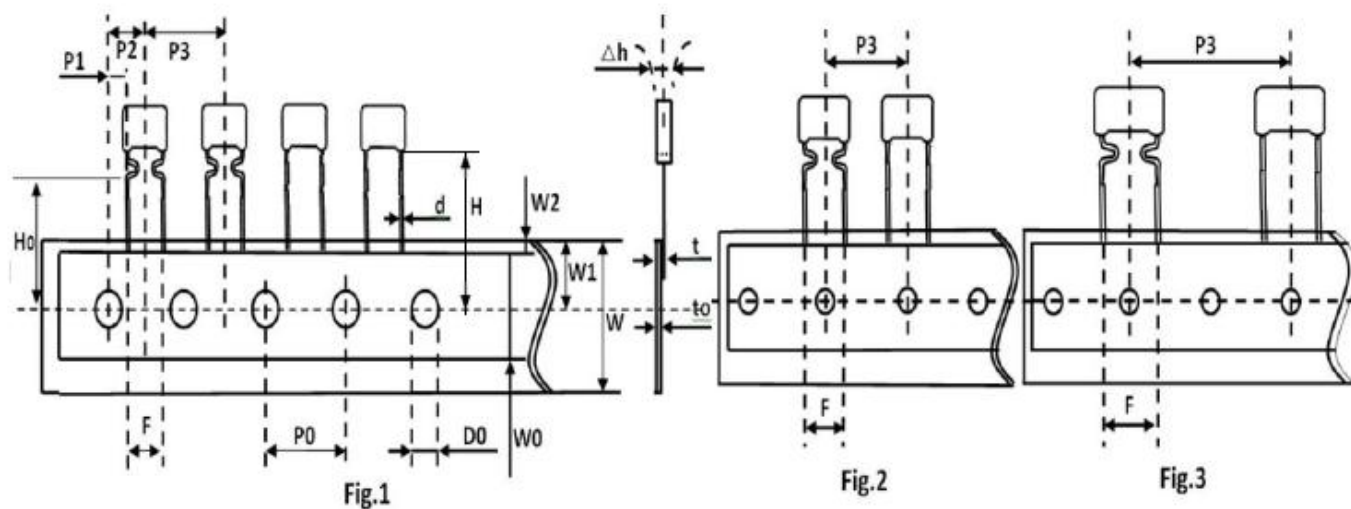

代码	Fig.1	Fig.2	Fig.2	Fig.3	Fig.3	误差
	P=5.0	P=7.5	P=10	P=15	P=20/22.5	
P3	12.7	12.7	12.7	25.4	30.0	±1.0
P2	6.35	/	/	/	/	±1.3
P0	12.7	12.7	12.7	12.7	15.0	±0.3
P1	3.85	/	/	/	/	±0.7
F	5.0	7.5	10.0	15.0	20.0/22.5	±1.0
H	20.0	20.0	20.0	20.0	20.0	±1.0
H0	16.5	16.5	16.5	16.5	16.5	±0.5
Δh	0	0	0	0	0	±2.0
W	18.0	18.0	18.0	18.0	18.0	+1.0/-0.5
W0	12.0	12.0	12.0	12.0	12.0	±1.0
W1	9.0	9.0	9.0	9.0	9.0	±0.5
W2	3.0	3.0	3.0	3.0	3.0	Max
D0	4.0	4.0	4.0	4.0	4.0	±0.3
d	0.5	0.6	0.6	0.8	0.8	±0.05
t	1.0	1.1	1.1	1.4	1.4	±0.2
t0	0.38	0.38	0.38	0.47	0.47	±0.04