

Factors Contributing to Successful Organizational Transformation at Kenya Wildlife Service

Rukia Atikiya Joyce Nzulwa

Jomo Kenyatta University of Agriculture and Technology, Nairobi-Kenya

Abstract

Existing research overwhelmingly puts a lot of emphasis on the importance of leadership in the transformation process. However, there is scarcity of literature on factors that influence successful organizational transformation. This study sought to determine the factors influencing successful organizational transformation at the Kenya Wildlife Service. The study employed a descriptive survey over a population of 50 supervisors at KWS Headquarters. The findings of the study revealed that clearly defined goals, top management involvement, HR capacity to manage change and financial control mechanisms are crucial for successful organizational transformation. Arising from the findings, the study recommended that organizations adopt a participatory corporate goal setting, sensitize the top management on corporate policy issues of as well as adoption of technology in financial risk mitigation.

Key words: Transformation; Strategy; Participatory; Sensitizing; Mitigation

1. Introduction

Organizational Transformation (OT) is the process through which an organization organization's strategic direction is radically altered, covering fundamental changes in structures, processes and behaviours (Cummins & Worley, 2005). Pascale (1990) defines OT as merely alteration of ways in which the organization does business and people interact with one another on a day-to-day basis. Sethi (2002) pointed observed that public confidence in corporate morality is on the decline and some corporations are beginning to reflect on how to gain back legitimacy in order to bridge corporate, social and environmental interests through transformational frameworks. As consequence, corporations' activities are currently scrutinized more closely by stakeholders in a quest to mainstreaming their operations as defined by the changes in the macro-environmental setups Waddock, (2000).

The Kenyan government relies on, tourism as one of the key economic streams. The sector directly employs more than 12% of the country's total active workforce and contributes to 10% of the GDP. The single most major player in the industry is the Kenya Wildlife Services (KWS), a state corporation established through an act of parliament CAP 376 of 1989. Its established came as a remedial intervention after its predecessor the Wildlife Conservation and Management Department (WCMD) failed in her mandate to manage the national parks curb poaching particularly of elephants and rhinos and also meet established revenue generation targets (KWS, 2005).

Despite heavy injection of donor funding and significantly evident successes in reduction of poaching, KWS still faces globally increased common threats to wildlife namely; human population growth, land pressure and ruthlessness to wildlife by landowners adversely affected by it. The main emerging threat in Kenya's tourist industry touches on political interferences leading to instabilities, insecurity and sound management of public affairs Kimilu, (2009). There has been need therefore to ensure a sound transformative agenda and process

position KWS as a corporate body able to counter the challenges therein as well deliver its mandate as a premier corporate body in the management of the tourism sector in Kenya..

II. Statement of the Problem

Kenya has a diverse assemblage of natural resources requiring huge financial resources. Overall, Kenya's wildlife protected areas have been estimated to have an annual value of US\$ 250 million. Despite the huge proceeds generated by the sector, little of this fund is ploughed back either to support conservation or to benefit communities which support conservation (Karanja, 2001). During the period between 1989 and 1998, KWS reflected an increasingly huge operating deficit. This was attributed largely to the low allocation of financial resources towards wildlife conservation by treasury which led to loss of keystone species with elephant population declining by approximately 85% and rhino population by around 97% by the late 1980s.

However, during the period between 1999 and 2004, KWS received a boost from the donor community keen to support the rehabilitation of the dilapidated infrastructure. The corporation received huge financial resources (KWS, 2004) which resulted into gradual improvement in the performance of Kenya wildlife service. The Overseas Development Institute (2009), pointed out that KWS did exceptionally well among its peers. The positive organizational transformation gave KWS prestigious corporate awards like the Company of the Year and Corporate Governance Award in 2009. The KWS success story has been outstanding and questions arise on whether it was only financial support which contributed to this. This study therefore sought to establish the factors that influenced the successful transformation at Kenya Wildlife Services.

III. Broad Objective of the Study

The broad objective of the study was to investigate the factors that influenced successful organizational transformation at Kenya Wildlife Service.

IV. Research Questions

The study sought to answer the following set of research questions:

1. To what extent does clarity of KWS goals influence its transformational success?
2. How did the top management's involvement in the transformational process influence the enlisted success?
3. What was the contribution of KWS HR towards enhancing its transformational success?
4. What key financial control mechanisms did KWS utilize in achieving its current transformation?

V. Literature Review

5.1. Theoretical Perspectives

The study was founded in the results based theory which espouses that organizational resources such as leadership, goal setting/definition, human resources, financial procedures and controls which are either tangible or intangible can be uniquely configured to deliver organizational success, particularly competitive advantage like transformation.

5.2. Goal Definition

Goals are a statement of what the organization or a subunit of the organization for example a function or department wishes to do. Clear goals are critical, because in the chaotic circumstances everything seems to be required at once, and there may be many actors with differing priorities (Collier et al., 2007). Bunker (1997), indicates that involving organizational members in goal setting helps reduce barriers to change by creating psychological ownership and promoting the dissemination of critical information. Kottler, (2007) asserts that in change management leaders should seek to set clear goals and communicate them well through every level of management. Barsky (2007) however argues that goal setting impedes ethical

decision making. Fleming and Zyglidopoulos (2008), opine that clear goals set with a focus to performance help employees to learn how to effectively perform a task. Locke and Latham, (2002) observed that poorly defined performance goals interfered with organizational learning.

5.3. Top Management Involvement

Senior management and managers in most well performing organizations birth and drive transformational agenda, vision and processes. This is especially so, if the organizational leadership has the support of a competent HR function rather than Organizational Development specialists. Kemp (1993) asserts that successful implementation of new programs depends on top management's ability to disseminate information about the change and convince employees of the urgency of change through the people's caregiver: human resource managers. Denhardt and Denhardt (1999) described how effective managers verify the need for change through "listening and learning" and then communicating those needs in ways that build support for change.

This is perhaps the most common piece of advice concerning change management, yet it is frustratingly hard to pinpoint, quantify or measure. Top management support and commitment to change plays an especially crucial role in transformational success (Burke et al., (2002). Kanter, (1983) & Kotter, (1995) assert that one or two managers can launch organizational renewal efforts. Alternately, management reforms around the globe for instance, reports attribute the failure of reforms in Canada to a lack of support from cabinet ministers, who simply did not care much about the reforms because the top did not persuade or cause a buy in to the reforms (Aucoin, 2001; Armenakis, Harris, &Field, 1999).

5.4. Capacity to Manage Change

The development and implementation of transformation strategies also require special capabilities (Armstrong, 2006). As Gratton, (1999) points out, transformation capability depends in part on the ability of an organization to create an embed processes which links business strategy to the behaviours and performance of individuals and teams. These clusters of processes link vertically to create alignment with short-term business needs, horizontally to create cohesion and temporarily to transform to meet future business needs. Conviction that leaders within the organization are able to manage a changing organization is a crucial foundation for growing employees' confidence toward a successful change program. Armenakis and Harris, (2002) aver that implementing organizational change is the most important, but the least understood skill of leaders. Gilmore (1997) found that numerous organizations have experienced less than desirable performance improvement and unfavorable employees' reactions to organizational changes due to conflicting programs in the organization's environment. Through program realignment, all programs and initiatives within an organization have to be managed to align with the ongoing change program.

Confidence that organization is able to deal with a challenging change is the reflection of change readiness. Sources of potential obstacle during change process have to be identified and anticipated. Pardo (2003) identified five fundamental sources of resistance to change in organizations. These include direct costs of change, cannibalization costs whereby change can bring success to a product but at the same time bring losses to others, hence it requires some sort of sacrifice (Rumelt, (1995; Lorenzo 2000). Different interests among employees and management, or lack of motivation of employees who value change leads to a higher ineptness on matters of transformation than managers' role would (Waddell & Sohal, 1998).

5.5. Financial Control Mechanisms

Sufficient resources are required to support the process of transformation. Considerable findings in literature inform that change is not cheap or devoid of trade-offs. Planned organizational change involves a redeployment or redirection of scarce organizational resources towards a host of new activities (Burke, 2002). Boynes (2003) found that resources are one of the important factors for improving public services and hence bringing about change. According to Berry, Checkerian, & Wechsler (1999), ample funding is

necessary to support staff in implementing change and to build the administrative and technical capacity for ensuring that the objectives are met. Accountability of allocated resources and the need for an effective financial system should be overemphasized to avoid wastages. There a cross section of researchers who argue that a good public financial management system is essential for the implementation of policies and the achievement of developmental objectives by supporting aggregate fiscal discipline, strategic allocation of resources and effective service delivery Abedian et al., (1998).

5.6. Knowledge Gap

One means of creating strategically competitive advantage in any industry is to enhance or perfect organizational transformation. Globally, organizational transformation has been studied across industries and is shown to increase organizational capabilities and value generation through exchange of resources, thus contributing to an organization’s competitive advantage (McEvily & Zaheer, 2009). In Kenyan context, limited literature exists on the subject of transformation particularly factors enhancing the transformation process. This potentially leads to inability to compare the status of organizational transformation in the country with major counterparts or a lost opportunity to learn from those that have been successful or success transformation stories.

5.6. Conceptual Framework

Deriving from the literature review, the following depicts the conceptualization of the study:

Fig 1: Conceptual Framework

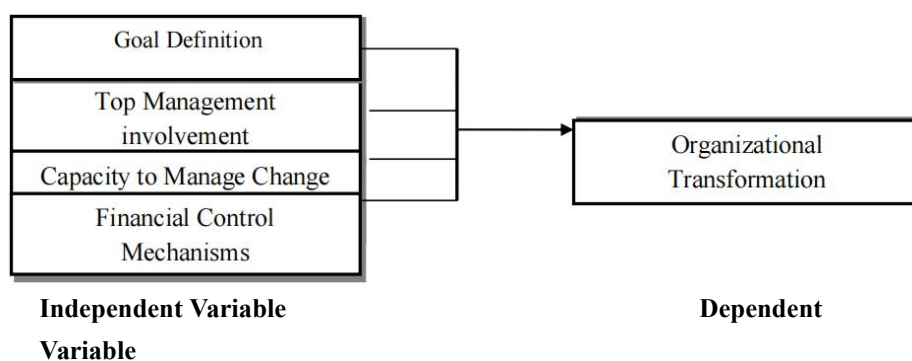

VI. Methodology

This study adopted a descriptive survey design to collect, measure, analyze and interpret collected data. The data was obtained through a questionnaire and desk review of organizational reports on strategic disposition. The study results were analyzed by use of descriptive statistics as well as inferential statistics.

VII. Sample

The target population was Kenya Wildlife Service’s managerial Staff at the Headquarter who deal with strategic matters and also were in-charge of administration of the transformational journey.

VIII. Findings and Discussion

8.1. Corporate Goals

The study established that 77% of the respondents in the study were well versed with their organizational corporate goals. The rest comprising 15% was not. Only 8% were aware at a moderate extent.

This signified a high level of value-emphasis that the top management had placed on information to their middle managers and staff. It was evident that managers understood their organization’s mandate and direction to achieve the expected transformation. This coincides with the work of Collier *et al.*, (2007) who said that clear

goals are critical amidst the chaos that surround organizations

8.2. Involvement in Goal Formulation and Implementation

Majority (93%) of the respondents acknowledged that they were often involved in determining goals in their departments/divisions and that they regularly converged with the strategists in deciding the level of goals to rank first over others. Those who were not often involved were 7% indicated that some key decisions requiring quick attention only needed the Managing Director in consultation with the Board of Directors to pass a resolution. The importance of this can be linked to the work of Bunker et al., (1997), which indicates that involving organizational members help reduce barriers to change by creating psychological ownership, promoting the dissemination of critical information, and encouraging employee feedback for the fine-tuning the change during implementation.

8.3. Extent of Management Commitment to Transformation Process

Out of the 47 who responded, At least 33% of the respondents appreciated the top management commitment to the transformation process at KWS by ranking their effort at 'extremely high extent'. Those with relative satisfaction lowered their ranking to high extent (24%) and moderate extent (28%). On the lower extreme, 11% rejected the top management quality of contribution at 'low extent' while there were 4% portion that rated it near zero or 'extremely low extent'. This implies that despite some negative concerns, the majority were satisfied with their equity to the job and subsequent commitment. This is supported by the work of Burke et al., (2002), who asserts that an individual or group within the organization should champion the cause for change and that top management support and commitment to change play an especially crucial role in success.

IX. Capacity to Manage Change

9.1. Human Resource Development

A well developed human resource is one of the key ingredients in boosting transformation in any organization due to associated ability to access information and using it for intended purposes. It is with this in mind that the research sought to establish the methods adopted by top management to develop the capacity of their staff in achieving the desired transformation. The findings revealed that jobs at KWS were well designed in each position and that the pay was commensurate to the call of duty. The staff portrayed high willingness to be sustained which was good for the transformation. This is supported by the work of Locke and Latham, (1990) who says that money is obviously the primary incentives since without it, few if any, employees would come to work. But they go far to say that money alone is not always enough to motivate high performance.

9.2. Financial Control Mechanism

The study also sought to find out the financial control techniques used by KWS. The study established that internal audit, staff sensitization and expenditure ceilings were highly preferred at 28%, 26% and 23% respectively as techniques for controlling the Corporation's funds. The other techniques were participatory budgeting and use of financial management soft ware's which were preferred at 17% and 6% respectively. From the analysis, it is inferred that KWS advocated for sound financial management system. However, the less adoption of financial management soft ware's and participatory budgeting suggested preference for more traditional and less accurate methods, which if incorporated would enhance efficiency and accountability. This is supported by the work of Abedian et al, (1998), who argued that a good public financial management system is essential in implementing policies and achievement of developmental objectives by supporting aggregate fiscal discipline, strategic allocation of resources and effective service delivery.

X. Conclusion and Recommendations

10.1. Conclusion

From the research findings, it is concluded that clearly defined corporate goals, top management

involvement, human resource capacity and financial resource control had a significant influence on the quality, quantity and speed with which KWS realized transformational success. The extent to which people are involved in goal formulation, implementation and cascading of the same among and across the entire staff is crucial in realizing transformation. Top management involvement is also very important and plays a key role as well as the human resource capacity and attitude towards transformation. Finally, the financial resource allocation and controls can influence a Corporation's transformation through staff awareness of various control techniques adopted and stakeholder involvement.

10.2. Recommendations

Based on the research conclusions, the study makes recommendations that more efforts should be made to make corporate goals entirely participatory starting right from formulation to implementation, monitoring and evaluation. This is imperative in creating a sense of belongingness for the operational managers and staff paramount in enhancing morale and sustainability of effort.

Top management deeded to be sensitized on corporate policy issues that touch on corporate governance, human resource capacity development, financial resourcing and collaborations with its stakeholders. This carries the potential to increasing efficiency and determination in directing resources to the most profitable operations that underpin the transformational agenda. Additionally, another research can be done covering a larger sample for comparable purposes or in the private sector to compare the dynamics therein. Finally, technology and its adoption in financial risk mitigation should be considered as extremely essential in driving most operations at the KWS.

References

- [1]Abramson, M.A. & Paul R. L.(2001). The Challenge of Transforming Organizations: Lessons Learned about Revitalizing Organizations. *Journal of Organizational Change Management*,Vol 1 (10).
- [2]Armenakis, A. A., and Harris, S.G. (2002). Crafting a change message to create transformational readiness, *Journal of Organizational Change Management*, 15(Number 2), 169-183.
- [3]Aucoin , P. (1990). *The New Public Management: Canada in Comparative Perspective*. Montreal,Canada: Institute for Research on Public Policy.
- [4]Bardach, E. (1977). *The Implementation Game*. Cambridge, MA: MIT Press.
- [5]Barsky, A. (2007). Understanding the ethical cost of organizational goal-setting: A review and theory development. *Journal of Business Ethics*, 81(1), 63-81.
- [6]Bazerman, M. H., & Chugh, D. (2006). Decisions without blinders. *Harvard Business Review*, 84(1), 88-97.
- [7]Beckhard, R (1989). A model for the executive management of transformational change, in *Human Resource Strategies*, ed London: G Salaman, Sage,.
- [8]Berry, F. S., Richard, C & Barton, W. (1999). *Reinventing Government*: University of Alabama Press.
- [9]Bingham, L. B. , and Charles R . W. (1996). The Administrative Dispute Resolution Act of 1990: How Do We Evaluate Its Success? *Journal of Public Administration Research and Theory* 6 (3): 383-411.
- [10]Bridges, W. (1991). *Managing transitions. Making the most of change*. Reading, Massachusetts: Perseus Books.
- [11]Bono, J. E., & Judge, T. A. (2003). Self-Concordance at work: Toward understanding themotivational effects of transformational leaders. *Academy of Management Journal*, 46, 554 -571.
- [12]Boyne, G. A. (2003). Sources of Public Service Improvement: A critical Review and Research and Theory 13 (3): 367-94.
- [13]Bunker , B . , and Billie T . Alban . 1997 . *Large Group Interventions: Engaging the Whole System for Rapid Change* . San Francisco : Jossey-Bass .
- [14]Burke , W . W. (2002) . *Organization Change: Theory and Practice* . Thousand Oaks, CA: Sage Publications

- Carnall , Colin . 1995 . *Managing Change in Organizations*. New York : Prentice Hall .
- [15]Burns, J. M. (1978) *Leadership*, New York: Harper and Row,
Carnall , C. 1(1995) . *Managing Change in Organizations*. New York : Prentice Hall .
- [16]Copper, D. R. and Emory, W. (2008), *Business Research Methods*, 2nd Ed. New York: Macmillan.
- [17]Denhardt ,R. B, & Janet V . D. (1999). *Leadership for Change: Case Studies in American Local Government* . Washington, DC : IBM Center for the Business of Government .
- [18]Fleming, P., & Zyglidopoulos, S. C. (2008). The Escalation of Deception in Organizations. *Journal of Business Ethics*, 81(4), 837-850. Gilmore, T., Shea, G., and Useem, M. (1997). Side effects of corporate culture transformations, *Journal of Applied Behavioral Science*, 33(June), 174-189.
- [19]Gratton, L (1999) People processes as a source of competitive advantage, in *Strategic Human Resource Management*, ed L Gratton et al, Oxford University Press,Oxford.
- [20]Jarrett, M. (2003), “The seven myths of change management”, *Business Strategy Review*, Vol. 14 No. 4, pp. 22-9.
- [21]Kimilu,S. (2009). *Strategy Formulation and Implementation at KWSin Nairobi*.Unpublished Thesis. Kenyatta University.
- [22]Kohn, A (1998) *Punished by rewrs*. USA. Houghton Mufflin.
- [23]Kothari C. R. (2008), *Research Methods and Techniques* (2nd ed.) New Delhi: (P) Limited, Publishers.
- [24]Kotter, J.P. (1996): *Leading Change*, United States: Harvard Business School Press. Locke, E. A., & Latham, G. P. (2006). New Directions in Goal-Setting Theory. *Current Directions in Psychological Science*, 15(5), 265-268.
- [25]Locke, E. A., & Latham, G. P. (2002). Building a practically useful theory of goal setting and task motivation: A 35-year odyssey. *American Psychologist*, 57(9), 705-717.
- [26]Locke, E. A and Latham, G. P (1990) *Goal setting and task performance*. Englewood Cliffs, NJ: Prentice Hall
Lukas, C., Holmes, S., Cohen, A., Restuccia, J., Cramer, I., Shwartz, M. and Charns, M. (2007), “ Transformational change in health care systems: an organizational model ” , *Health Care Management Review*, Vol. 32 No. 4, pp. 309-20.
- [27]Mugenda, O. M. and Mugenda, A. G. (2003). *Research Methods, Quantitative and Qualitative approach*, Nairobi, Acts Press.
- [28]Pardo del Val, Manuela and Martinez Fuentes, Clara. (2003). Resistance to change: a literature review and empirical study, *Management Decision*, 41(Number 2), 149-155.
- [29]Rumelt, R.P. (1995). Inertia and transformation. In Montgomery, Cynthia A. (Eds.) *Resources in an evolutionary perspective: towards a synthesis of evolutionary and resource-based approaches to strategy*, pp. 101-132. Norwel : Kluwer Academic Publishers.
- [30]Sethi S.: (2002), 'Standards for Corporate Conduct in the International Arena: Challenges and Opportunities for Multinational Corporations', *Business and Society Review* 107, 20-40
- [31]Tenbrunsel, A. E., Wade-Benzoni, K. A., Messick, D. M., & Bazerman, M. H. (2000). Understanding the Influence of Environmental Standards on Judgments and Choices. *The Academy of Management Journal*, 43(5), 854-866.
- [32]Tushman, M, Newman, W and Nadler, D (1988) Executive leadership and organizational evolution, managing incremental an discontinuous change, in *Corporate transformation; Revitalizing organizations for a competitive world*.
- [33]Kilmann and T Covin, Jossey-Bass, San Francisco.
- [34]Waddock S.: (2000), *The Multiple Bottom Lines of Corporate Citizenship: Social Investing, Reputation, and Responsibility Audits*, *Business and Society Review* (105), 323-345.